

# TEST SOCKETS & ADAPTERS

# 03

## Presentation

Learn more on <a href="http://www.e-tec.com">www.e-tec.com</a>	2
A long precision manufacture story	3
Welcome to E-tec Interconnect AG	4
Contents of the Catalog	5
For which applications? / The 6 questions to build test socket and define your part number	6
What kind of packages?	7
Mounting solutions introduction	8
Retention / Retainer frames models	12
Test Sockets Options	16

## For BGA / Bumped chip / WLCSP / eMMC Package

0.30 mm pitch (from 0.30 mm to 0.39 mm)	Probe Pin Solderless Compression Test Socket	20
	Elastomer Solderless Compression Test Socket	22
0.40 mm pitch (from 0.40 mm to 0.49 mm)	Probe Pin Solderless Compression Test Socket	24
	Elastomer Solderless Compression Test Socket	26
0.50 mm pitch (from 0.50 mm up to 0.79 mm)	Through-hole (THT) soldering Test Socket	29
	Standard SMT soldering Test Socket	30
	Raised SMT soldering Test Socket	31
	Probe Pin Solderless Compression Test Socket	32
	Elastomer Solderless Compression Test Socket	34
0.80 mm pitch (from 0.80 mm up to 0.99 mm)	Through-hole (THT) soldering Test Socket	37
	Standard SMT soldering Test Socket	38
	Raised SMT soldering Test Socket	39
	Probe Pin Solderless Compression Test Socket	40
	Elastomer Solderless Compression Test Socket	42
1.00 mm pitch (from 1.00 mm up to 1.26 mm)	Through-hole (THT) soldering Test Socket	45
	Standard SMT soldering Test Socket	46
	Raised SMT soldering Test Socket	47
	Probe Pin Solderless Compression Test Socket	48
	Elastomer Solderless Compression Test Socket	50
1.27 mm pitch (from 1.27 mm upwards)	Through-hole (THT) soldering Test Socket	53
	Standard SMT soldering Test Socket	54
	Raised SMT soldering Test Socket	55
	Probe Pin Solderless Compression Test Socket	56
	Elastomer Solderless Compression Test Socket	58

## For LGA / QFN / MLF / MLP / LCC Package

0.30 mm pitch (from 0.30 mm to 0.39 mm)	Probe Pin Solderless Compression Test Socket	60
	Elastomer Solderless Compression Test Socket	62
0.40 mm pitch (from 0.40 mm to 0.49 mm)	Probe Pin Solderless Compression Test Socket	64
	Elastomer Solderless Compression Test Socket	66
0.50 mm pitch (from 0.50 mm up to 0.79 mm)	Through-hole (THT) soldering Test Socket	69
	Standard SMT soldering Test Socket	70
	Raised SMT soldering Test Socket	71
	Probe Pin Solderless Compression Test Socket	72
	Elastomer Solderless Compression Test Socket	74
0.80 mm pitch (from 0.80 mm up to 0.99 mm)	Through-hole (THT) soldering Test Socket	77
	Standard SMT soldering Test Socket	78
	Raised SMT soldering Test Socket	79
	Probe Pin Solderless Compression Test Socket	80
	Elastomer Solderless Compression Test Socket	82
1.00 mm pitch (from 1.00 mm up to 1.26 mm)	Through-hole (THT) soldering Test Socket	85
	Standard SMT soldering Test Socket	86
	Raised SMT soldering Test Socket	87
	Probe Pin Solderless Compression Test Socket	88
	Elastomer Solderless Compression Test Socket	90
1.27 mm pitch (from 1.27 mm upwards)	Through-hole (THT) soldering Test Socket	93
	Standard SMT soldering Test Socket	94
	Raised SMT soldering Test Socket	95
	Probe Pin Solderless Compression Test Socket	96
	Elastomer Solderless Compression Test Socket	98

### For CGA / PGA / PGI Package

0.30 mm pitch (from 0.30 mm to 0.39 mm)	Probe Pin Solderless Compression Test Socket	100
0.40 mm pitch (from 0.40 mm to 0.49 mm)	Probe Pin Solderless Compression Test Socket	102
0.50 mm pitch (from 0.50 mm up to 0.79 mm)	Through-hole (THT) soldering Test Socket	105
	Standard SMT soldering Test Socket	106
	Raised SMT soldering Test Socket	107
	Probe Pin Solderless Compression Test Socket	108
0.80 mm pitch (from 0.80 mm up to 0.99 mm)	Through-hole (THT) soldering Test Socket	111
	Standard SMT soldering Test Socket	112
	Raised SMT soldering Test Socket	113
	Probe Pin Solderless Compression Test Socket	114
1.00 mm pitch (from 1.00 mm up to 1.26 mm)	Through-hole (THT) soldering Test Socket	117
	Standard SMT soldering Test Socket	118
	Raised SMT soldering Test Socket	119
	Probe Pin Solderless Compression Test Socket	120
1.27 mm pitch (from 1.27 mm upwards)	Through-hole (THT) soldering Test Socket	123
	Standard SMT soldering Test Socket	124
	Raised SMT soldering Test Socket	125
	Probe Pin Solderless Compression Test Socket	126

### For SOP / DSO / SOIC / QFP / xQFP Package

0.40 mm pitch (from 0.40 mm to 0.49 mm)	Probe Pin Solderless Compression Test Socket	128
0.50 mm pitch (from 0.50 mm up to 0.79 mm)	Through-hole (THT) soldering Test Socket	131
	Standard SMT soldering Test Socket	132
	Raised SMT soldering Test Socket	133
	Probe Pin Solderless Compression Test Socket	134
0.80 mm pitch (from 0.80 mm up to 0.99 mm)	Through-hole (THT) soldering Test Socket	137
	Standard SMT soldering Test Socket	138
	Raised SMT soldering Test Socket	139
	Probe Pin Solderless Compression Test Socket	140
1.00 mm pitch (from 1.00 mm up to 1.26 mm)	Through-hole (THT) soldering Test Socket	143
	Standard SMT soldering Test Socket	144
	Raised SMT soldering Test Socket	145
	Probe Pin Solderless Compression Test Socket	146
1.27 mm pitch (from 1.27 mm upwards)	Through-hole (THT) soldering Test Socket	149
	Standard SMT soldering Test Socket	150
	Raised SMT soldering Test Socket	151
	Probe Pin Solderless Compression Test Socket	152

### Adapters

THT / SMT adapter for Test Socket	154
ABG adapter series	157
SMT / THT MGS adapter series	159
SMT Solderball MGS adapter series	160
ZIF Test Socket, for Flex Cables, displays and membrane keyboards	161
Socket mounting recommendation & Reflow profile	163
Other Products	168





## A long precision manufacture story



*Since more than 40 years E-tec Interconnect has been active in the electronics interconnection field (IC Sockets, PCB interconnect products, D-Sub's, Switches, RF Connectors, etc.) and 20 years' experience in Test Socket and adaptors on a world-wide basis. E-tec Interconnect offers a very comprehensive range of industry standard products as well as many customized products which can be found in a variety of application fields, such as aeronautics, military, medical, communications, automotive, multi-media and many others.*

*Thanks to our own production facility we aim to offer a solution to all your problems.*

*Quality assurance is an essential part of our production process, since our main objective is to offer products which correspond to the highest quality standards.*

### **Mission statement**

*Each customer has their own need and constraints. Space available, pitch, package or specific test each, all of this influence the test socket structure.*

*E-tec Interconnect has decided 25 years ago to invest in acknowledgment.*

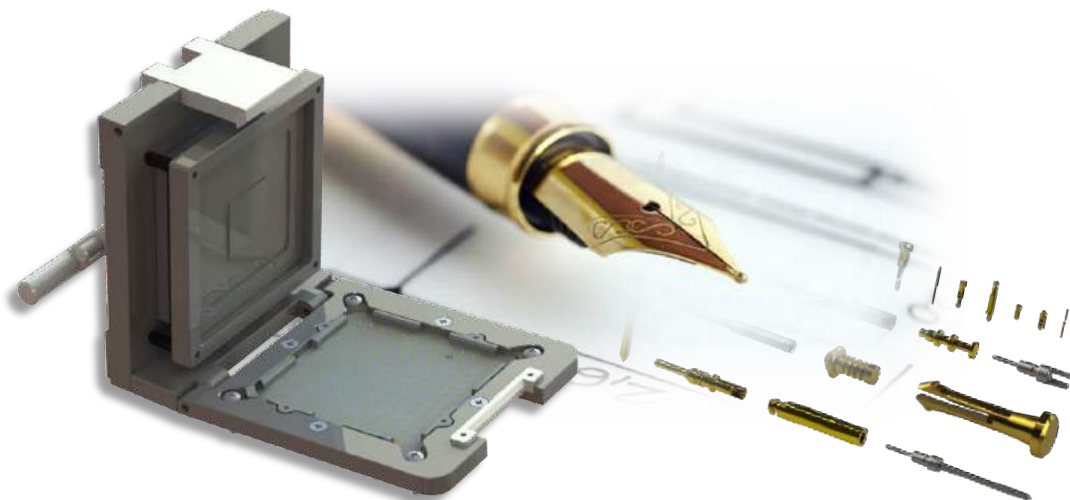

## Welcome to E-tec Interconnect AG

*In 1996, **E-tec Interconnect** designed with success its first Test socket for their first BGA application, thanks to his long precise spare part manufacturing history. E-tec Interconnect registered patent for this new spring probe socket.*

*Since this period, **E-tec Interconnect** develops his experience and acknowledgment and now designs and manufactures any kind of **Test Sockets**, **Burn-in** sockets, **Debug & ATE** sockets.*

***E-tec Interconnect** keeps the same working principle, to pass the signal through a spring contact, but have involved and adapted it, for each of customer specific cases or applications. For semiconductor, military, automotive or space markets, E-tec Interconnect team reduced the pitch step by step to reach the smallest pitches; increased the frequency while we reduce impedance and perturbation in same time; enlarge the range of temperature on both side.*

### **Why E-tec Interconnect has success?**

*You can ask us for any kind of layout, in regular or totally irregular pitch, full populated or not, without extra cost.*

*You can get adapted and customized test socket as you need.*

*You can get the 3D STEP file for a fast and accurate control.*

*You can ask modification according this 3D verifying according your own boards constraints.*

*You're not invoiced of any charges or any NRE for customization. (Only if you talk about tooling for custom injected socket).*

*You have a very fast and efficient lead-time.*

*You can have a special team for you, to get up to 3 working days on departure, even if it is for a custom design.*



## Contents of the catalog

*Here you will find all the information you need to choose the test sockets you need to meet your test requirements. For 40 years, E-tec Interconnect has taken great care to utilize our extensive engineering experience and leading edge technology to offer high performance test sockets and interconnects.*

*Anxious to display real characteristics and not just simulated on computer, this performance data is (dually) analyzed and controlled in the laboratory on physical sockets, (under real test conditions).*

*We know that everyone is unique because even with similar characteristics, your constraints whether electrical or mechanical will never be the same from one project to another. It is for this reason that we have cultivated a real customer approach.*

*E-tec Interconnect carefully focuses and listens to you, the customer. We have developed throughout our exchanges with project managers and engineers, a wide range of options and adaptations that can adapt to the majority of our sockets.*

*We are pleased to present our newly updated catalog of high quality products. We are confident that you will find an excellent solution to your testing interconnect requirements. Working with you, our engineering team will help design the highest performance, cost effective sockets and test interconnects available on the market today.*





## For which applications?

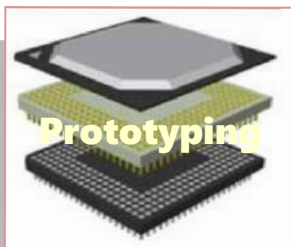

## The 6 questions to build test socket and define your part number

- 1<sup>st</sup>: for what kind of **package**?
- 2<sup>nd</sup>: for what kind of **pitch**?
- 3<sup>rd</sup>: for what kind of test socket **mounting**?
- 4<sup>th</sup>: for what kind of **retention frame (lid)**?
- 5<sup>th</sup>: for what kind of test / **specifications**?
- 6<sup>th</sup> : any **special request** ?(open top dimensions, restrictive area, mandatory layout and fixture, ... )





## What kind of packages?

We can support all kind of packages and pitches from 0.30 mm.

Package can be with or without leads, with or without balls, flat or bent, with regular pitch or completely irregular one. From the simplest up to the most complex shape.

To help you to find the right Test socket according your package, we classified and group packages as follows



### **Balled package**

Page 20 - 58

: BGA, xBGA, eMMC, eWLB, Bumped chip

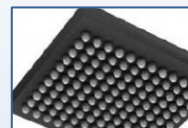

### **Vertical Pin package**

Page 100 - 126

: PGA, PGI, CGA



### **Flatpack package**

Page 128 - 152

: Dual or Quad Flatpack  
(leads not bent)  
Refer to "gull wings" packages

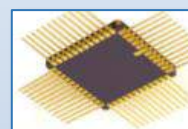

### **Without leads package**

Page 60 - 98

: QFN, MLF, LCC, LGA ...



### **"Gullwings" bent leads package**

Page 128 - 152

: PLCC, xQFP, TSSOP, SOIC, TSOP, DSO, SOP



### **Multichip package / Custom package**

Page 60 - 98

: PoP, SiP, WSI, castellation Pkg  
(refer to LGA family)



## Mounting solutions introduction

### THT Test Socket:

The Through-hole socket uses the same footprint as your chip. The socket is simply placed and wave soldered onto the PCB in the same way as the chip and it only requires a minimal amount of additional board space. Through-hole sockets are available with all retention systems. Please note, we will always request the chip data to ensure we provide a compatible socket.

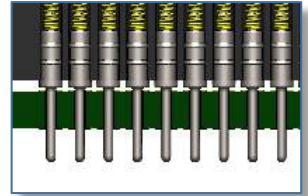

### SMT Test Socket:

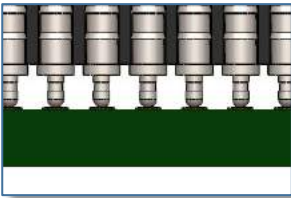

The E-tec Interconnect SMT socket is a very clever solution when you want to use a test socket without any modification on your board. Its high electrical performances will make it an excellent option to use in the majority of your designs.

SMT sockets use the same footprint as your chip. The socket is simply placed and reflowed onto the PCB in the same way as the chip and it only requires a small amount of additional board space.

SMT sockets are available with all retention systems. We aim to solve your requirements - many different terminals and configurations are available. Please note, we will always request the chip data to ensure we offer a compatible socket. For SMT sockets in general, E-tec Interconnect recommends the use of locating pegs, which can be soldered to the PCB for added mechanical strength.

### Raised SMT Test Socket:

The E-tec Interconnect Raised SMT socket is a great solution when you don't need to save maximum space on your board.

The Raised SMT socket lifts the socket above close-by components on the PCB and uses the same footprint as your chip and requires no additional surface. The socket is simply placed and reflowed onto the PCB in the same way as the chip and it only requires a small amount of additional board space.

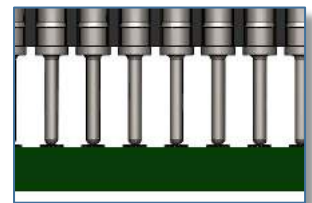

Again, we aim to solve your requirements. For Raised SMT sockets in general, E-tec Interconnect recommends the use of locating pegs, which can be soldered to the PCB for added mechanical strength.

### SMT / THT Adapter:

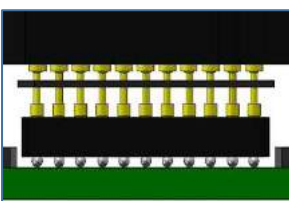

Most of the E-tec Interconnect Test Sockets can be transposed on a SMT adapter, with excellent efficiency and reliability.

Thanks to this solution, E-tec Interconnect is able to place a socket instead of the active component, onto a board even if it is not designed to receive any type of test socket, up to 0.4 mm pitch.

*The SMT adapter is available either with solderball or with solid pin terminals. This SMT adapter emulates the chip's BGA footprint and is easily installed using standard flux and reflow techniques. The solder ball adapters have the same solder ball types as the IC's they are emulating. You can combine the SMT foot with any of the E-tec Interconnect socket styles shown in the Test Socket Catalog. The corresponding male BGA socket, through hole type, is plugged into the adapter.*

## **Solderless Pogo Pin Test socket:**

*The E-tec Interconnect solderless compression type sockets are an excellent solution for maximum reliability with high frequency performance.*

*Solderless compression type sockets are available for any chip size and grid pattern.*

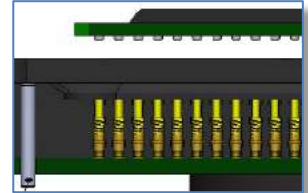

*The solderless socket is easily mounted to the PCB with 2, 4 or 8 through hole mounting pegs. The assembly board ensures perfect coplanarity of the socket. Contact reliability is guaranteed with spring loaded gold plated contacts, which are pressed onto gold plated PCB pads. Solderless compression type sockets are available with all retention systems. Our goal is to solve your requirements - many different terminals and configurations are available.*

## **Solderless Elastomer Test Socket:**

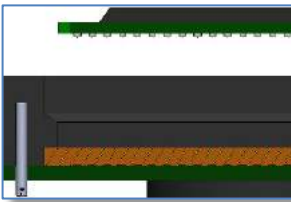

*The E-tec Interconnect Elastomer sockets are an ideal technical solution for excellent signal integrity with low signal loss.*

*E-tec Interconnect Elastomers are available for any chip size and pitch to 0.3 mm pitch. Our different options enable us to offer our customers several thicknesses and contact density, to reach the best performance on the market, at greater than 40 GHz (at -1dB in insertion loss S21), with a very stable impedance at 50 Ohm.*

*The standard version is the solderless socket style, which is attached with 2, 4 or 8 screws to connecting to the PCB. SMT and through-hole adapter sockets are available in certain pitches (please contact our factory for availability) with these elastomer interposers to allow using this high frequency interposer on PCB's which have already been laid out for SMT or through-hole sockets. The retainer can be delivered with a center opening for die access and the socket outline will be kept to a minimum and special clearances can be offered to avoid components on the PCB.*

*The E-tec Interconnect Elastomer socket can be continuously used in applications with temperatures up to 125°C and with intermittent peaks to higher temperatures.*

## Mounting solutions

**E-tec Interconnect** proposes you all kind of mounting you could need in aim to manage your test of your component, thanks to his large range of capability:

- Through hole
- SMT pin
- Raised SMT
- Solderless compression
- Elastomer solderless compression
- Solderballs *(thanks to adapter)*

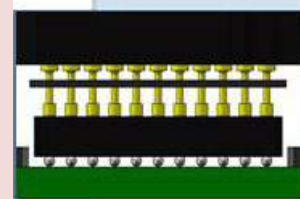
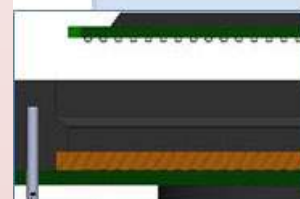
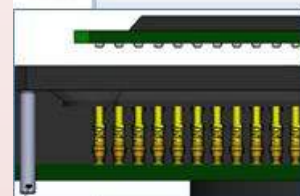
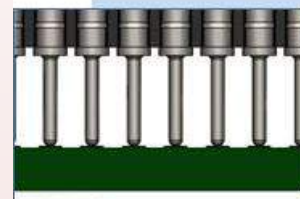
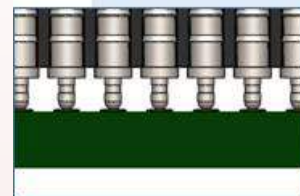



## Global view summary

	Mounting style				
Pitch available	Through-hole style <b>(##70)</b>	SMT style <b>(##30)</b>	Raised SMT style <b>(##28 / ##29)</b>	Solderballs style <i>(thanks to an adpater)</i>	Solderless style <b>(##9#)</b>
From 0.3 mm to 0.4 mm	no	no	no	no	yes
From 0.4 mm to 0.5 mm	no	no	no	no	yes
From 0.5 mm to 0.8 mm	yes	yes	yes	yes	yes
From 0.8 mm to 1.0 mm	yes	yes	yes	yes	yes
From 1.0 mm to 1.27 mm	yes	yes	yes	yes	yes
From 1.27 mm and higher	yes	yes	yes	yes	yes
Spring Pogo pin style	yes	yes	yes	yes	yes
Elastomeric style	no	no	no	no	yes
Advantage	the cheapest mounting style	no impact on PCB	the best solution to take the least space on PCB	same reflow process as a smt component	no soldering process to fix
Drawback	difficult to find PCB vendor with metalized holes < 0.6 mm	soldering way similar as a QFP package	need requires to have a sticking process for fixing	need to pass thru a adapter	a little bit more expensive compare other technologies
Electrical specifications	very good 3GHz	very good 3GHz	good < 3GHz	good < 3GHz	excellent up to 40 GHz

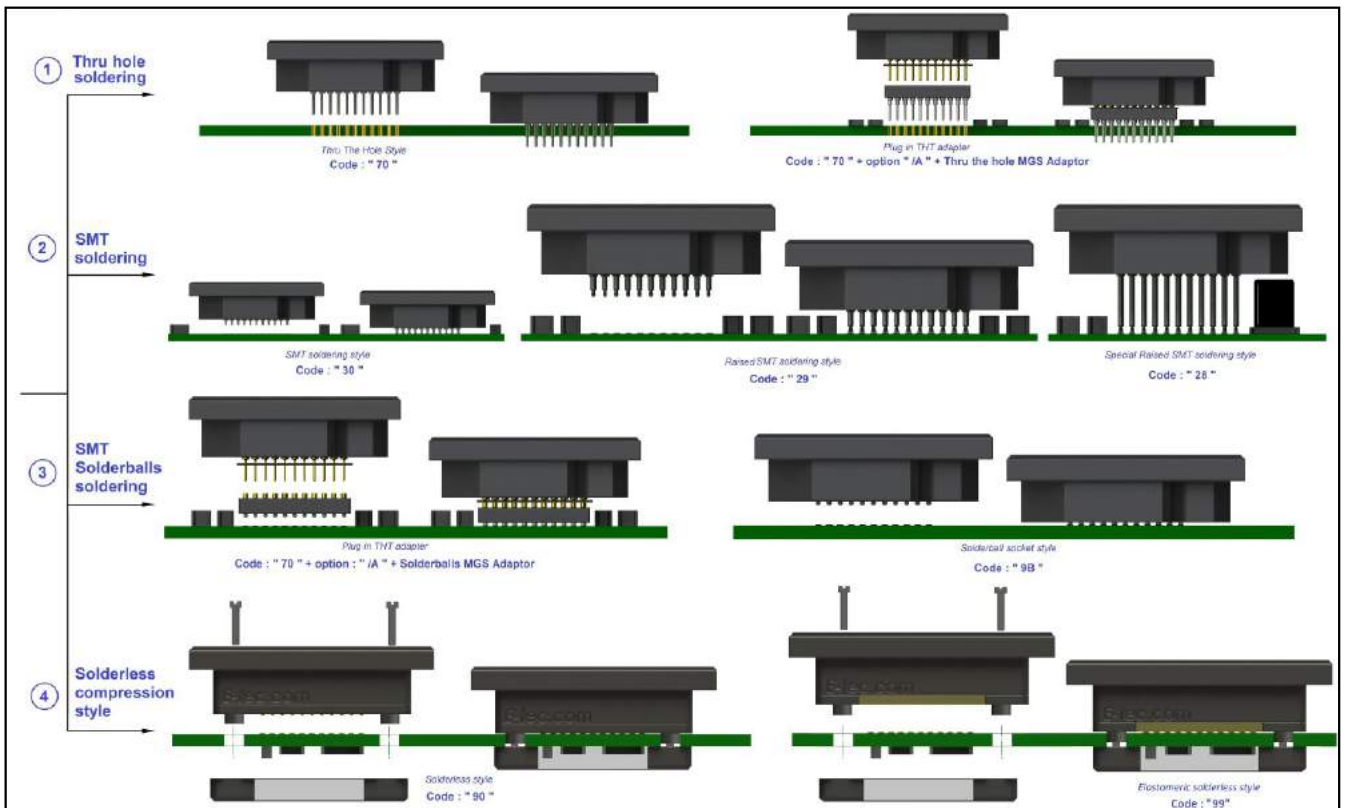

**E-tec Interconnect** takes special care to support the needs of his clients, and so naturally develop and large range of choice for the retention frame. All of them, can be selected on any socket base thanks to some light adaptation. Furthermore, all of them are open top. Last advantage, on not the least, almost of our retention frame accept a large variation.

**TwistLock**  
(Code: **W**)

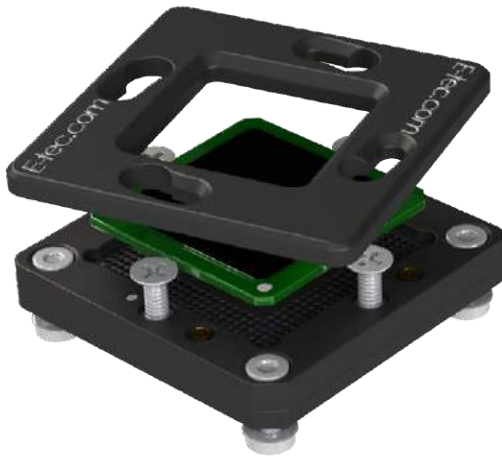

**ScrewLock**  
(Code: **S**)

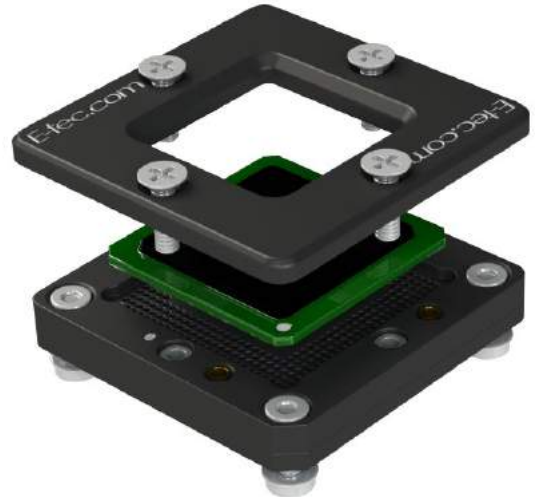

**FastLock**  
(Code: **F**)

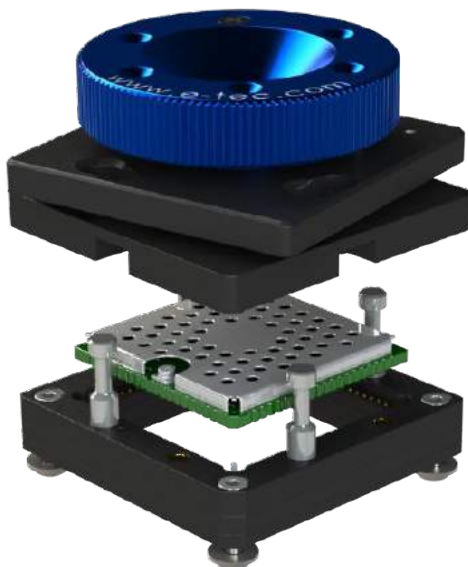

**SpringLock**  
(Code: **B**)



**Open Clamshell Alu**  
(<200 contacts chip)  
(Code: **H**)

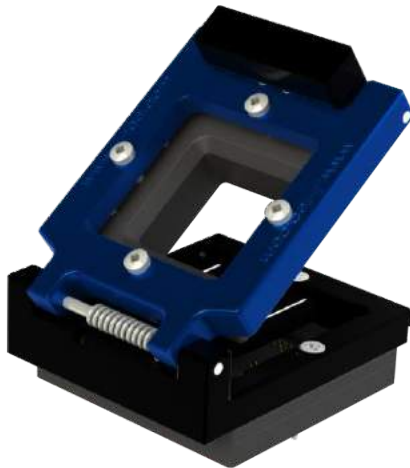

**Clamshell Alu**  
(>200 contacts chip)  
(Code: **J**)



**Open Lever Clamshell Alu**  
(>200 contacts chip)  
(Code: **L**)



**Injection Molded**  
(Code: **M**)



**Open QuickLock**  
(<200 contacts chip)  
(Code: **Q**)

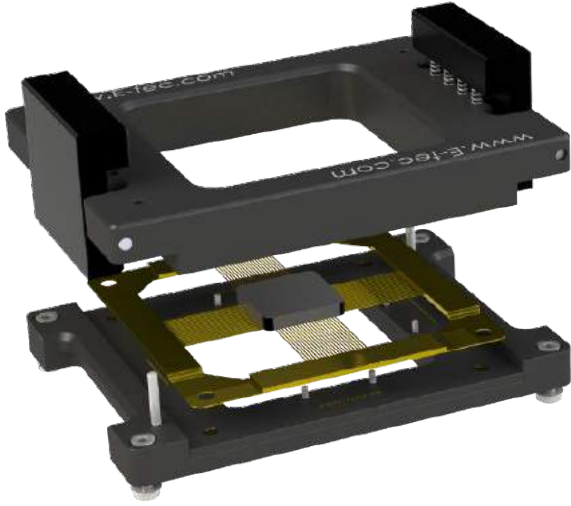

**QuickLock**  
(>200 contacts chip)  
(Code: **D**)

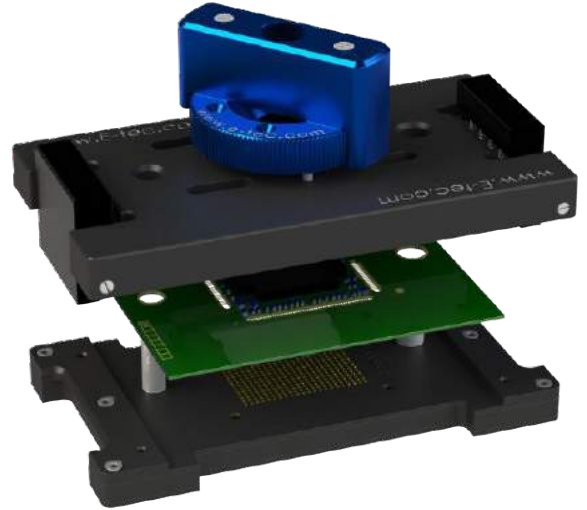

**ReverseLock**  
(Code: **R**)



**SlimLock**  
(Code: **T**)





## Specifications

### Retention / Retainer frames models



The below chart will help you to make the right choice of Retention / Retainer frame for your Test Socket.

The indicated information refers to standard options. If you should not find what you need or if your specs should vary from the below chart, please contact your closest E-tec office, since we will most likely be able to offer a customized solution.

Retention frame style	Socket Cost	Open top	Open/close cycles	Socket outline dimension	Socket height above board	Tools required to open/close	Torque tool option	available with integrated heatsink	Accepted max. chip height variations from min to max
TwistLock / ScrewLock	low	yes	1 K	smallest	lowest	yes	yes	yes	3.0 mm
FastLock	low	yes	10 K	small	high	no	yes	yes	2.5 mm
SpringLock	low	yes	10 K	small	medium	no	no	yes	2.0 mm
Open Clamshell Alu (<200 contacts)	medium	yes	25 K	large	medium	no	no	yes	1.0 mm
Clamshell Alu (>200 contacts)	medium	yes	25 K	large	high	no	yes	yes	2.5 mm
Open Lever Clamshell Alu (>200 contacts)	medium	yes	25 K	large	medium	no	no	yes	1.0 mm
Open QuickLock (<200 contacts)	medium	yes	25 K	medium	medium	no	no	yes	1.0 mm
QuickLock (>200 contacts)	medium	yes	25 K	medium	high	no	yes	yes	2.5 mm
Injection Molded ClamShell	low	no	10 K	medium	medium	no	yes	no	1.0 mm
ReverseLock	medium	yes	10 K	large	high	no	yes	yes	2.5 mm
SlimLock	medium	yes	10 K	smallest	high	no	yes	yes	2.5 mm

**Dead bug**  
(Option code: **D**)



**Multi frames**  
(Option code: **M**)



**Multi packages**  
(Option code: **U**)



**Custom opening slot**  
(Option code: **S**)

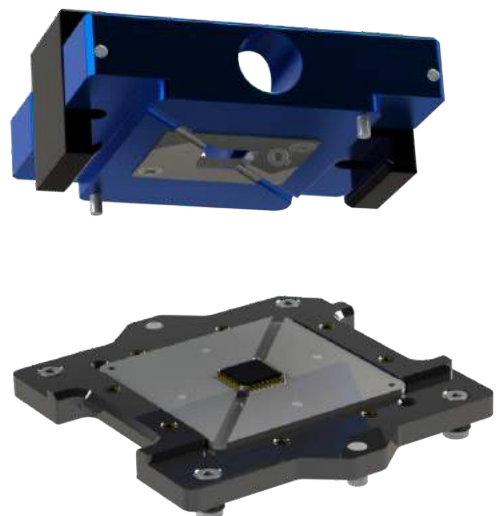

**Heatsink**  
(Option code: **H**)



**Fan + Heatsink**  
(Option code: **HF**)



**Thermal drain pad**  
(Option code: **T**)



**Transparent lid**  
(Option code: **W**)



**Steel retention lid**  
(Option code: **i**)



**Aluminum retention lid**  
(Option code: **B**)



**Torque tool fixture**  
(Option code: **T**)



**LGA to BGA Converter plate**  
(Option code: **C**)

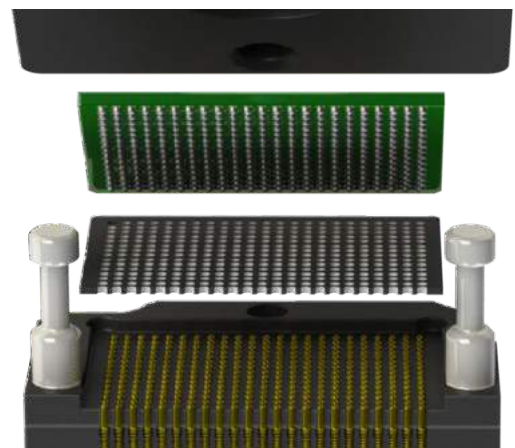



**Locating peg**  
(Option code: **L**)



**Handling button**  
(Option code: **G**)



# Probe Pin Solderless Compression Test Socket

For BGA / Bumped chip / WLCSP / eMMC Package

0.30 mm pitch (from 0.30 mm to 0.39 mm)

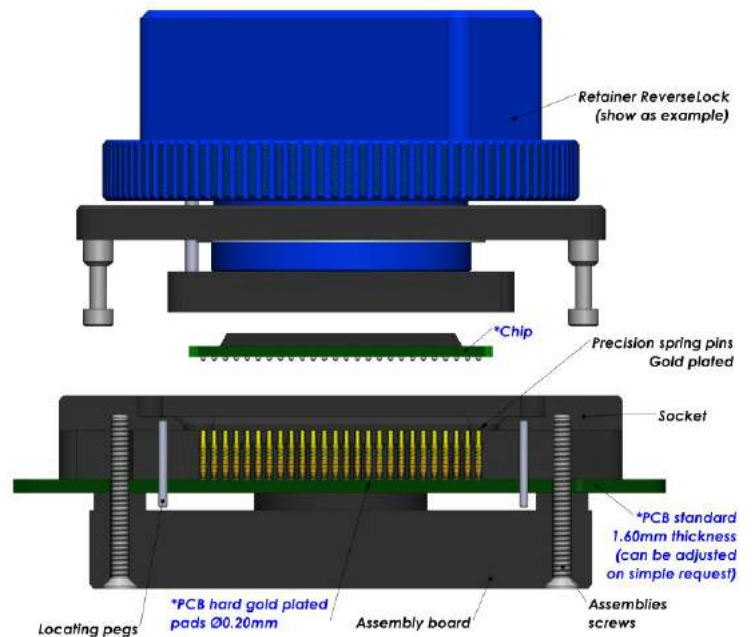
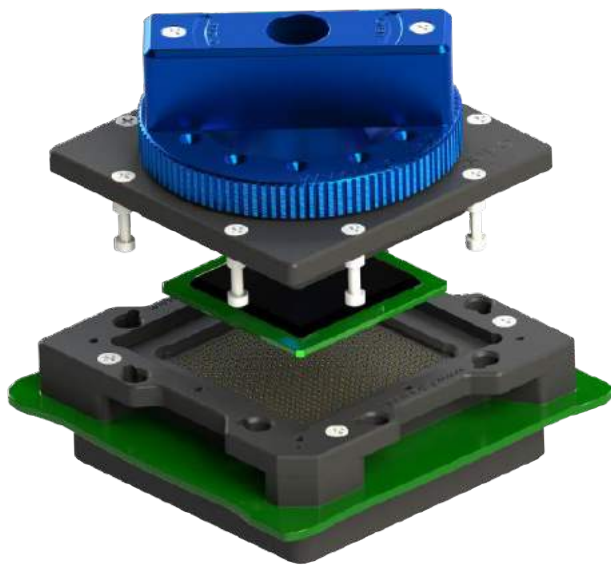

**E-tec Interconnect AG is the world leading Test socket manufacturer**

Probe Pin (Pogo) Solderless compression Test Sockets type are available for any chip size and pitch and are attached with 2, 4 or 8 screws to the PCB. The assembly board ensures perfect coplanarity of the socket. Contact reliability is guaranteed with spring loaded gold plated contacts, which are pressed onto gold plated PCB pads. Probe Pin (Pogo) Solderless compression type sockets are available with all retention systems. We aim to solve your requirements. Please note, we will always request the chip data to ensure we offer a compatible socket.

Contacts Specifications	
Contact type code	0398
Application	High Frequency
Mounting	Solderless
Bandwidth (GHz@-1dB)	19 GHz
Contact resistance	<100 mOhm
Chip contact tip shape	Single Point tip
PCB tip shape	Single Point tip
Force	17 gr
Current rating	0.8 A
Capacitance pF	0.50 pF
Inductance nH	1.27 nH
Impedance Ohms	45 Ω
Temperature range	-45°C to +125°C
Mating cycles	150 K

More on the next page

# Probe Pin Solderless Compression Test Socket

For BGA / Bumped chip / WLCSP / eMMC Package

0.30 mm pitch (from 0.30 mm to 0.39 mm)

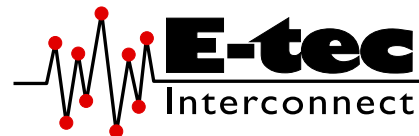

## Standard assembly boards

Small Chip size



Medium Chip size

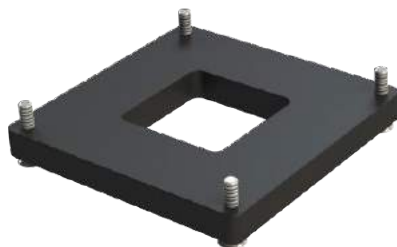

Large Chip size



## Custom assembly boards

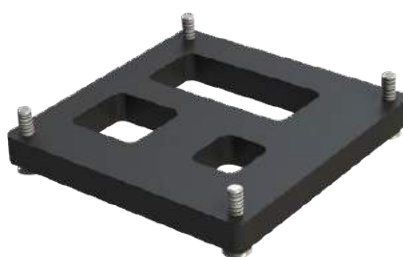

## How to order

**BU # # # # # -0398 - # # # # # # 55L #**

<p><b>Shape of tip</b></p> <p><b>U</b> : Concave</p> <p><b>Options:</b></p> <p><b>P</b> : Pointed</p> <p><b>C</b> : Crown</p>	<p><b>Nbr of contacts</b></p> <p>Depends on ballcount of chip</p>	<p><b>Contact type</b></p> <p>98 : See "Contacts specification" chart</p>	<p><b>Plating</b></p> <p><b>55L</b>: Gold + Locating pegs</p> <p>Other on request</p>	<p><b>Option code</b> (see page 16-19)</p> <p><b>D</b> : Dead bug</p> <p><b>M</b> : Multi frames</p> <p><b>U</b> : Multi packages</p> <p><b>S</b> : Custom opening slot</p> <p><b>H</b> : Heatsink</p> <p><b>F</b> : Fan + Heatsink</p> <p><b>P</b> : Thermal drain pad</p> <p><b>W</b> : Transparent lid</p> <p><b>I</b> : Steel retention lid</p> <p><b>B</b> : Aluminium retention lid</p> <p><b>T</b> : Torque tool fixture</p> <p><b>G</b> : Handling button</p>
<p><b>Retention frame type (Lid)</b> (see page 12-15)</p> <p><b>W</b>: TwistLock</p> <p><b>F</b> : FastLock</p> <p><b>B</b> : SpringLock</p> <p><b>H</b> : Open Clamshell Alu (&lt;200 contacts)</p> <p><b>J</b> : Clamshell Alu (&gt;200 contacts)</p> <p><b>L</b> : Open Lever Clamshell Alu (&gt;200 contacts)</p> <p><b>S</b> : ScrewLock</p> <p><b>Q</b> : Open QuickLock (&lt;200 contacts)</p> <p><b>D</b> : QuickLock (&gt;200 contacts)</p> <p><b>M</b> : Injection Molded ClamShell</p> <p><b>R</b> : ReverseLock</p> <p><b>T</b> : SlimLock</p>		<p><b>Grid code / Config. code</b></p> <p>Will be given by the factory after receipt of the chip datasheet</p>		



# Elastomer Solderless Compression Test Socket

For BGA / Bumped chip / WLCSP / eMMC Package

0.30 mm pitch (from 0.30 mm to 0.39 mm)

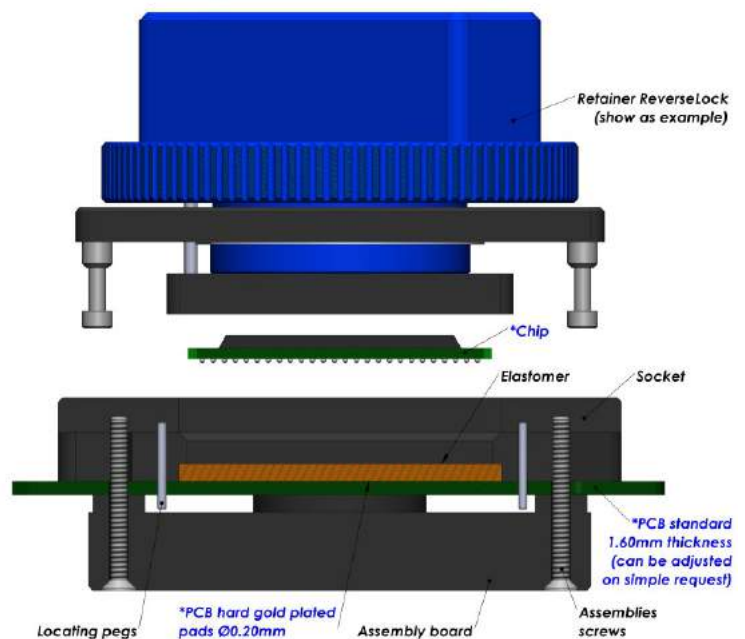

## E-tec Interconnect AG is the world leading Test socket manufacturer

The elastomer solderless compression test sockets are ideal technical solution for good signal integrity with low signal loss. The sockets are available for any chip size and pitch and are attached with 2, 4 or 8 screws to the PCB. The socket outline will be kept to a minimum and special clearances can be offered to avoid components on the PCB. SMT and thru-hole adapter sockets are available in certain pitches (contact factory for availability first) with these elastomer interposers to allow using this high frequency interposer on PCB's which have already been laid out for SMT or thru-hole sockets. We aim to solve your requirements. Please note, we will always request the chip data to ensure we offer a compatible socket.

Contacts Specifications		
Contact type code	E2	E3
Application	High Frequency	
Mounting	Solderless	Solderless
Bandwidth (GHz@-1dB)	20.3 GHz*	18.3 GHz*
Contact resistance	30 mOhm	
Chip contact tip shape	Gold Wire	
PCB tip shape	Gold Wire	
Force	20 gr to 50 gr	
Current rating	1 A	
Capacitance pF	0.15 pF	0.14 pF
Inductance nH	0.12 nH	0.05 nH
Impedance Ohms	41 Ω	39.7 Ω
Temperature range	-40°C to +125°C	
Mating cycles	1 K	

\* Tested at 0.35mm Pitch

More on the next page



# Elastomer Solderless Compression Test Socket

For BGA / Bumped chip / WLCSP / eMMC Package

0.30 mm pitch (from 0.30 mm to 0.39 mm)

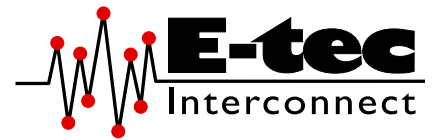

## Standard assembly boards

Small Chip size



Medium Chip size

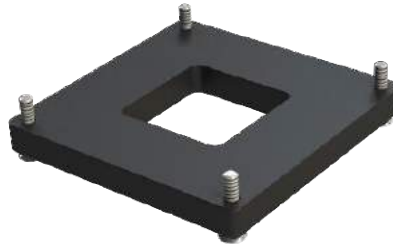

Large Chip size



## Custom assembly boards

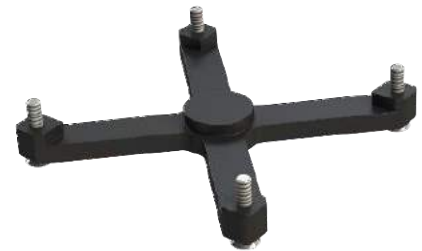
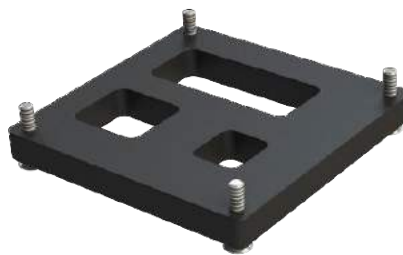
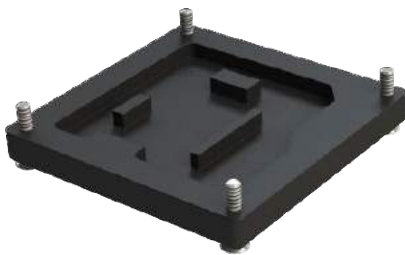

## How to order

**BE# #### -03E# - ##### 55L #**

**Shape of tip**  
E : Elastomer

**Nbr of contacts**  
Depends on ballcount of chip

**Contact type**  
E2 : High Frequency 20.3 GHz  
E3 : High Frequency 18.3 GHz

**Plating**  
55L: Gold + Locating pegs

**Option code** (see page 16-19)

- M : Multi frames
- U : Multi packages
- S : Custom opening slot
- H : Heatsink
- F : Fan + Heatsink
- W : Transparent lid
- I : Steel retention lid
- B : Aluminium retention lid
- G : Handling button

**Retention frame type (Lid)** (see page 12-15)

- W: TwistLock
- F : FastLock
- B : SpringLock
- H : Open Clamshell Alu (<200 contacts)
- J : Clamshell Alu (>200 contacts)
- L : Open Lever Clamshell Alu (>200 contacts)
- S : ScrewLock
- Q : Open QuickLock (<200 contacts)
- D : QuickLock (>200 contacts)
- M : Injection Molded ClamShell
- R : ReverseLock
- T : SlimLock

**Grid code / Config. code**  
Will be given by the factory after receipt of the chip datasheet

# Probe Pin Solderless Compression Test Socket

For BGA / Bumped chip / WLCSP / eMMC Package

0.40 mm pitch (from 0.40 mm to 0.49 mm)

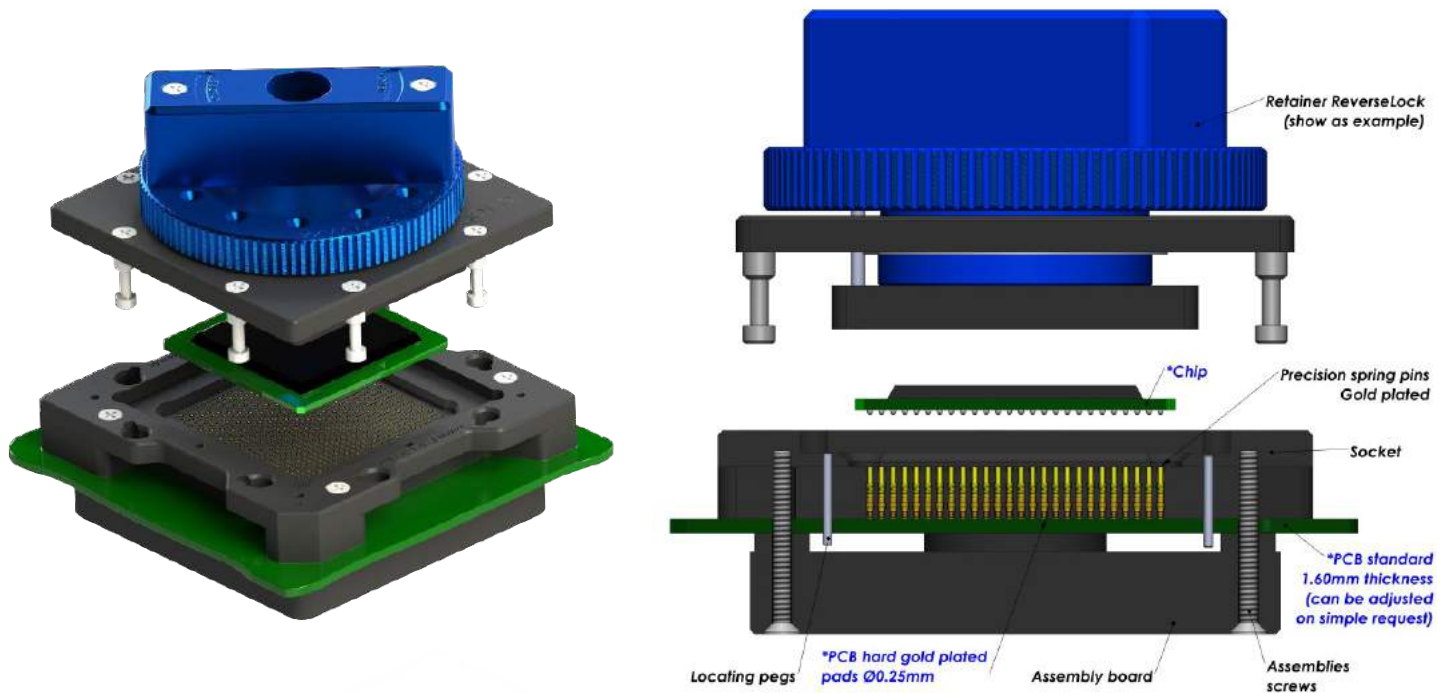

***E-tec Interconnect AG is the world leading Test socket manufacturer***

Probe Pin (Pogo) Solderless compression Test Sockets type are available for any chip size and pitch and are attached with 2, 4 or 8 screws to the PCB. The assembly board ensures perfect coplanarity of the socket. Contact reliability is guaranteed with spring loaded gold plated contacts, which are pressed onto gold plated PCB pads. Probe Pin (Pogo) Solderless compression type sockets are available with all retention systems. We aim to solve your requirements. Please note, we will always request the chip data to ensure we offer a compatible socket.

Contacts Specifications				
Contact type code	0490	0491	0492	0494
Application	Standard	Frequency	High Frequency	High Power
Mounting	Solderless	Solderless	Solderless	Solderless
Bandwidth (GHz@-1dB)	3 GHz	10 GHz	20 GHz	na
Contact resistance	<100 mOhm	100 mOhm	100 mOhm	100 mOhm
Chip contact tip shape	Single Point tip	Single Point tip	Single Point tip	Crown tip
PCB tip shape	Spring	Single Point tip	Single Point tip	Single Point tip
Force	20 gr	20 gr	20 gr	30 gr
Current rating	0.5 A	1.5 A	1.5 A	3 A
Capacitance pF	<1pF	0.90 pF	0.50 pF	na
Inductance nH	<2nH	1.50 nH	1.20 nH	na
Impedance Ohms	45 Ω	48 Ω	42 Ω	na
Temperature range	-55°C to +150°C	-40°C to +120°C	-40°C to +120°C	-40°C to +120°C
Mating cycles	100 K	300 K	100 K	100 K

More on the next page



# Probe Pin Solderless Compression Test Socket

For BGA / Bumped chip / WLCSP / eMMC Package

0.40 mm pitch (from 0.40 mm to 0.49 mm)

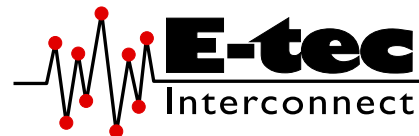

## Standard assembly boards

Small Chip size



Medium Chip size

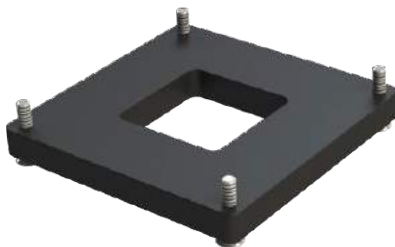

Large Chip size



## Custom assembly boards

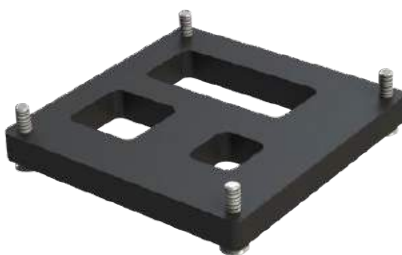
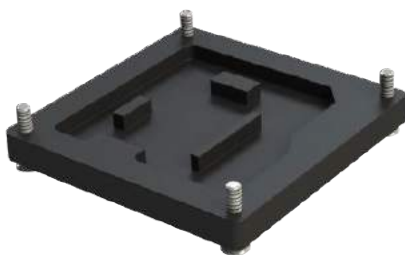

## How to order

**BU # # # # -049# - # # # # # 55L #**

<p><b>Shape of tip</b></p> <p>U : Concave</p> <p><b>Options:</b></p> <p>P : Pointed</p> <p>C : Crown</p>	<p><b>Nbr of contacts</b></p> <p>Depends on ballcount of chip</p>	<p><b>Contact type</b></p> <p>91 to 94 : See "Contacts specification" chart</p> <p>90 : Standard solderless compression style</p> <p>9M : Special mixed contact style</p>	<p><b>Plating</b></p> <p>55L: Gold + Locating pegs</p> <p>Other on request</p>	<p><b>Option code</b> (see page 16-19)</p> <p>D : Dead bug</p> <p>M : Multi frames</p> <p>U : Multi packages</p> <p>S : Custom opening slot</p> <p>H : Heatsink</p> <p>F : Fan + Heatsink</p> <p>P : Thermal drain pad</p> <p>W : Transparent lid</p> <p>I : Steel retention lid</p> <p>B : Aluminium retention lid</p> <p>T : Torque tool fixture</p> <p>G : Handling button</p>
<p><b>Retention frame type (Lid)</b> (see page 12-15)</p> <p>W: TwistLock</p> <p>F : FastLock</p> <p>B : SpringLock</p> <p>H : Open Clamshell Alu (&lt;200 contacts)</p> <p>J : Clamshell Alu (&gt;200 contacts)</p> <p>L : Open Lever Clamshell Alu (&gt;200 contacts)</p> <p>S : ScrewLock</p> <p>Q : Open QuickLock (&lt;200 contacts)</p> <p>D : QuickLock (&gt;200 contacts)</p> <p>M : Injection Molded ClamShell</p> <p>R : ReverseLock</p> <p>T : SlimLock</p>		<p><b>Grid code / Config. code</b></p> <p>Will be given by the factory after receipt of the chip datasheet</p>		



# Elastomer Solderless Compression Test Socket

For BGA / Bumped chip / WLCSP / eMMC Package

0.40 mm pitch (from 0.40 mm to 0.49 mm)

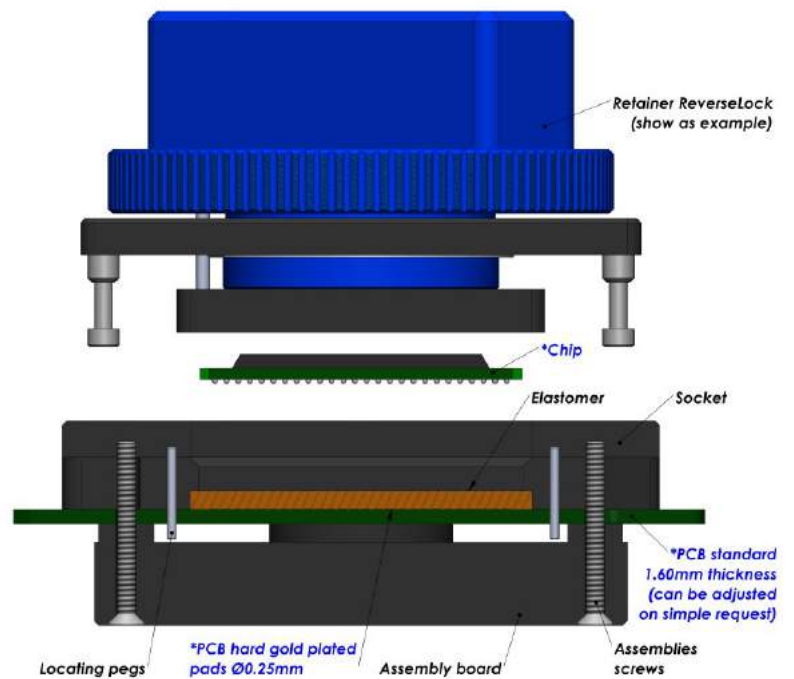

## E-tec Interconnect AG is the world leading Test socket manufacturer

The Elastomer Solderless compression Test Sockets are ideal technical solution for good signal integrity with low signal loss. The sockets are available for any chip size and pitch and are attached with 2, 4 or 8 screws to the PCB. The socket outline will be kept to a minimum and special clearances can be offered to avoid components on the PCB.

SMT and thru-hole adapter sockets are available in certain pitches (contact factory for availability first) with these elastomer interposers to allow using this high frequency interposer on PCB's which have already been laid out for SMT or thru-hole sockets. We aim to solve your requirements. Please note, we will always request the chip data to ensure we offer a compatible socket.

Contacts Specifications			
Contact type code	E1	E2	E3
Application	High Frequency		
Mounting	Solderless	Solderless	Solderless
Bandwidth (GHz@-1dB)	8.4 GHz	16.5 GHz	21.3 GHz
Contact resistance	30 mOhm		
Chip contact tip shape	Gold Wire		
PCB tip shape	Gold Wire		
Force	20 gr to 50 gr		
Current rating	2.5 A		
Capacitance pF	0.28 pF	0.13 pF	0.10 pF
Inductance nH	0.26 nH	0.07 nH	0.06 nH
Impedance Ohms	34.7 Ω	38.9 Ω	42.1 Ω
Temperature range	-40°C to +125°C		
Mating cycles	1 K		

More on the next page



# Elastomer Solderless Compression Test Socket

For BGA / Bumped chip / WLCSP / eMMC Package

0.40 mm pitch (from 0.40 mm to 0.49 mm)



## Standard assembly boards

Small Chip size



Medium Chip size

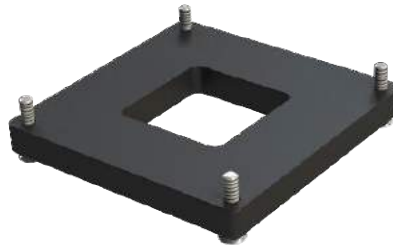

Large Chip size



## Custom assembly boards

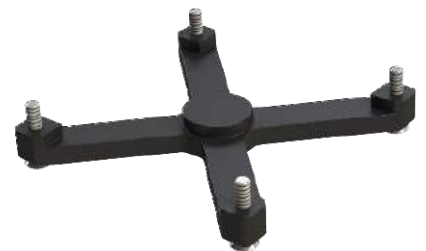
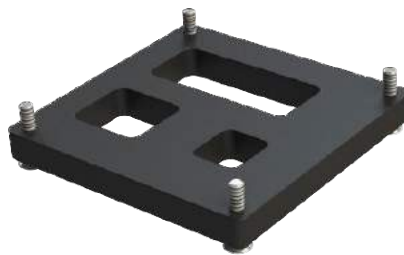
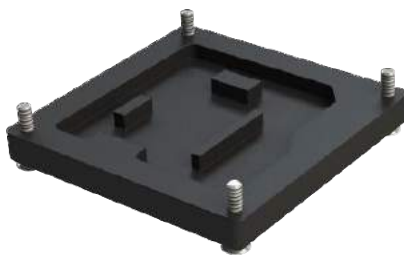

## How to order

**BE# #### -04E# - ##### 55L #**

<p><b>Shape of tip</b></p> <p><b>E</b> : Elastomer</p>	<p><b>Nbr of contacts</b></p> <p>Depends on ballcount of chip</p>	<p><b>Contact type</b></p> <p><b>E1</b> : High Frequency 8.4 GHz  <b>E2</b> : High Frequency 16.5 GHz  <b>E3</b> : High Frequency 21.3 GHz</p>	<p><b>Plating</b></p> <p><b>55L</b>: Gold + Locating pegs</p>	<p><b>Option code</b> (see page 16-19)</p> <p><b>M</b> : Multi frames  <b>U</b> : Multi packages  <b>S</b> : Custom opening slot  <b>H</b> : Heatsink  <b>F</b> : Fan + Heatsink  <b>W</b> : Transparent lid  <b>I</b> : Steel retention lid  <b>B</b> : Aluminium retention lid  <b>G</b> : Handling button</p>
<p><b>Retention frame type (Lid)</b> (see page 12-15)</p> <p><b>W</b>: TwistLock  <b>F</b> : FastLock  <b>B</b> : SpringLock  <b>H</b> : Open Clamshell Alu (&lt;200 contacts)  <b>J</b> : Clamshell Alu (&gt;200 contacts)  <b>L</b> : Open Lever Clamshell Alu (&gt;200 contacts)</p> <p><b>S</b> : ScrewLock  <b>Q</b> : Open QuickLock (&lt;200 contacts)  <b>D</b> : QuickLock (&gt;200 contacts)  <b>M</b> : Injection Molded ClamShell  <b>R</b> : ReverseLock  <b>T</b> : SlimLock</p>		<p><b>Grid code / Config. code</b></p> <p>Will be given by the factory after receipt of the chip datasheet</p>		





# Through-hole (THT) soldering Test Socket

For BGA / Bumped chip / WLCSP / eMMC Package

0.50 mm pitch (from 0.50 mm up to 0.79 mm)

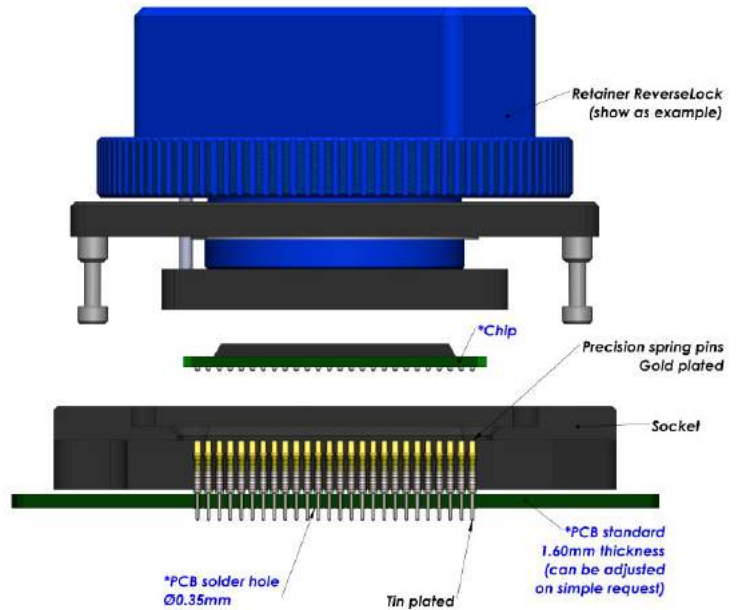
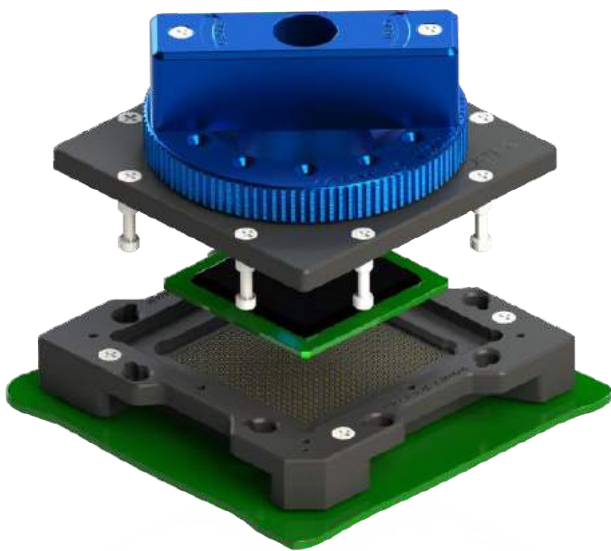

**E-tec Interconnect AG is the world leading Test socket manufacturer**

The Through-hole socket uses the same footprint as your chip. Socket is simply placed and wave soldered onto the PCB in the same way as the chip and it only requires a small amount of additional board space. Through-hole sockets are available with all retention systems. Please note, we will always request the chip data to ensure we offer a compatible socket.

Specifications contact type code 0570			
Application	Through-hole technology	Force	30 gr
Mounting	THT	Current rating	1 A
Bandwidth (GHz@-1dB)	2.7 GHz	Capacitance pF	< 1 pF
Contact resistance	<100mOhm	Inductance nH	< 2 nH
Chip contact tip shape	Single Point tip or Concave tip	Temperature range	-55°C to +150°C
PCB tip shape	Through-hole	Mating cycles	100 K

## How to order

**BU # #### -0570 - ##### 95 #**

<p><b>Shape of tip</b></p> <p>U : Concave</p> <p><b>Options:</b></p> <p>P : Pointed</p> <p>S : Spring</p> <p>C : Crown</p>	<p><b>Nbr of contacts</b></p> <p>Depends on ballcount of chip</p>	<p><b>Contact type</b></p> <p>70 : Standard THT</p>	<p><b>Plating</b></p> <p>95: Tin / Gold</p> <p>Other on request</p>	<p><b>Option code</b> (see page 16-19)</p> <p>D : Dead bug</p> <p>M : Multi frames</p> <p>U : Multi packages</p> <p>S : Custom opening slot</p> <p>L : Locating pegs</p> <p>A : Alignment plate</p> <p>H : Heatsink</p> <p>F : Fan + Heatsink</p> <p>P : Thermal drain pad</p> <p>W : Transparent lid</p> <p>I : Steel retention lid</p> <p>B : Aluminium retention lid</p> <p>T : Torque tool fixture</p> <p>G : Handling button</p>
<p><b>Retention frame type (Lid)</b> (see page 12-15)</p> <p>W : TwistLock</p> <p>F : FastLock</p> <p>B : SpringLock</p> <p>H : Open Clamshell Alu (&lt;200 contacts)</p> <p>J : Clamshell Alu (&gt;200 contacts)</p> <p>L : Open Lever Clamshell Alu (&gt;200 contacts)</p>		<p><b>Grid code / Config. code</b></p> <p>Will be given by the factory after receipt of the chip datasheet</p>		
		<p>S : ScrewLock</p> <p>Q : Open QuickLock (&lt;200 contacts)</p> <p>D : QuickLock (&gt;200 contacts)</p> <p>M : Injection Molded ClamShell</p> <p>R : ReverseLock</p> <p>T : SlimLock</p>		



**Standard SMT soldering Test Socket**  
 For BGA / Bumped chip / WLCSP / eMMC Package  
**0.50 mm pitch** (from 0.50 mm up to 0.79 mm)

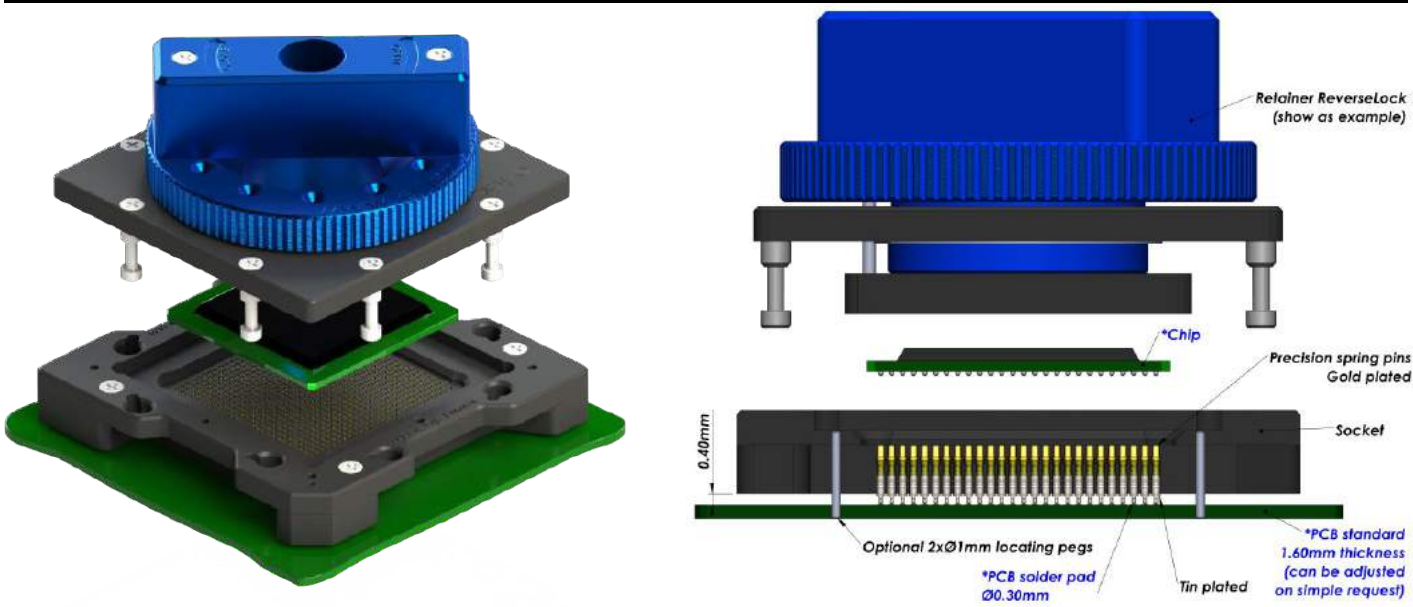
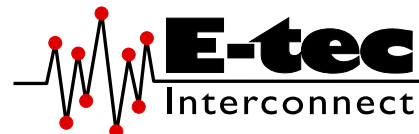

**E-tec Interconnect AG is the world leading Test socket manufacturer**

The SMT socket uses the same footprint as your chip. Socket is simply placed and reflowed onto the PCB in the same way as the chip and it only requires a small amount of additional board space. SMT type sockets are available with all retention systems. We aim to solve your requirements. Please note, we will always request the chip data to ensure we offer a compatible socket. For SMT sockets in general, E-tec Interconnect AG recommends the use of locating pegs, which can be soldered to the PCB for added mechanical strength.

Specifications contact type code 0530			
Application	Surface mouting	Force	30 gr
Mounting	SMT	Current rating	1 A
Bandwidth (GHz@-1dB)	2.7 GHz	Capacitance pF	< 1 pF
Contact resistance	<100mOhm	Inductance nH	< 2 nH
Chip contact tip shape	Single Point tip or Concave tip	Temperature range	-55°C to +150°C
PCB tip shape	SMT	Mating cycles	100 K

**How to order**

**BU # #### -0530 - ##### 95 #**

<p><b>Shape of tip</b></p> <p>U : Concave</p> <p><b>Options:</b></p> <p>P : Pointed</p> <p>S : Spring</p> <p>C : Crown</p>	<p><b>Nbr of contacts</b></p> <p>Depends on ballcount of chip</p>	<p><b>Contact type</b></p> <p>30 : Standard SMT – dimension A = 0.40 mm</p>	<p><b>Plating</b></p> <p>95 : Tin / Gold</p> <p>Other on request</p>	<p><b>Option code</b> (see page 16-19)</p> <p>D : Dead bug</p> <p>M : Multi frames</p> <p>U : Multi packages</p> <p>S : Custom opening slot</p> <p>L : Locating pegs</p> <p>H : Heatsink</p> <p>F : Fan + Heatsink</p> <p>P : Thermal drain pad</p> <p>W : Transparent lid</p> <p>I : Steel retention lid</p> <p>B : Aluminium retention lid</p> <p>G : Handling button</p>
<p><b>Retention frame type (Lid)</b> (see page 12-15)</p> <p>W : TwistLock</p> <p>F : FastLock</p> <p>B : SpringLock</p> <p>H : Open Clamshell Alu (&lt;200 contacts)</p> <p>J : Clamshell Alu (&gt;200 contacts)</p> <p>L : Open Lever Clamshell Alu (&gt;200 contacts)</p>		<p>S : ScrewLock</p> <p>Q : Open QuickLock (&lt;200 contacts)</p> <p>D : QuickLock (&gt;200 contacts)</p> <p>M : Injection Molded ClamShell</p> <p>R : ReverseLock</p> <p>T : SlimLock</p>		<p><b>Grid code / Config. code</b></p> <p>Will be given by the factory after receipt of the chip datasheet</p>



# Raised SMT soldering Test Socket

For BGA / Bumped chip / WLCSP / eMMC Package  
**0.50 mm pitch** (from 0.50 mm up to 0.79 mm)

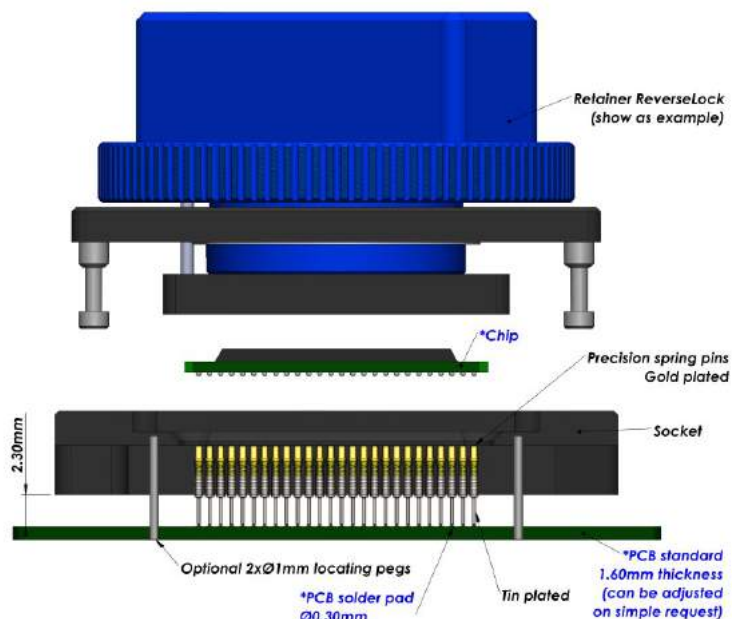
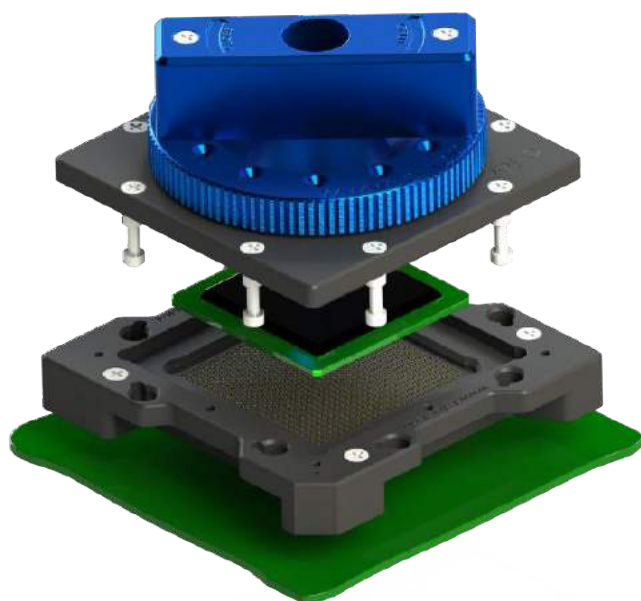

**E-tec Interconnect AG is the world leading Test socket manufacturer**

The Raised SMT socket lifts the socket above close-by components on PCB and uses the same footprint as your chip. Socket is simply placed and reflowed onto the PCB in the same way as the chip and it only requires a small amount of additional board space. Raised SMT sockets are available with all retention systems. We aim to solve your requirements. Please note, we will always request the chip data to ensure we offer a compatible socket. For Raised SMT sockets in general, E-tec Interconnect AG recommends the use of locating pegs, which can be soldered to the PCB for added mechanical strength.

Specifications contact type code 0529			
Application	Surface mouting	Force	30 gr
Mounting	Raised SMT	Current rating	1 A
Bandwidth (GHz@-1dB)	na	Capacitance pF	na
Contact resistance	<100mOhm	Inductance nH	na
Chip contact tip shape	Single Point tip or Concave tip	Temperature range	-55°C to +150°C
PCB tip shape	Raised SMT	Mating cycles	100K

## How to order

**BU # # # # -0529 - # # # # # 95A #**

<p><b>Shape of tip</b></p> <p>U : Concave</p> <p><b>Options:</b></p> <p>P : Pointed</p> <p>S : Spring</p> <p>C : Crown</p>	<p><b>Nbr of contacts</b></p> <p>Depends on ballcount of chip</p>	<p><b>Contact type</b></p> <p>29 : Raised SMT – Dimension A = 2.30 mm</p>	<p><b>Plating</b></p> <p>95A: Tin/Gold + Alignment plate</p> <p>Other on request</p>	<p><b>Option code</b> (see page 16-19)</p> <p>D : Dead bug</p> <p>M : Multi frames</p> <p>U : Multi packages</p> <p>S : Custom opening slot</p> <p>L : Locating pegs</p> <p>H : Heatsink</p> <p>F : Fan + Heatsink</p> <p>P : Thermal drain pad</p> <p>W : Transparent lid</p> <p>I : Steel retention lid</p> <p>B : Aluminium retention lid</p> <p>T : Torque tool fixture</p> <p>G : Handling button</p>
<p><b>Retention frame type (Lid)</b> (see page 12-15)</p> <p>W: TwistLock</p> <p>F : FastLock</p> <p>B : SpringLock</p> <p>H : Open Clamshell Alu (&lt;200 contacts)</p> <p>J : Clamshell Alu (&gt;200 contacts)</p> <p>L : Open Lever Clamshell Alu (&gt;200 contacts)</p> <p>S : ScrewLock</p> <p>Q : Open QuickLock (&lt;200 contacts)</p> <p>D : QuickLock (&gt;200 contacts)</p> <p>M : Injection Molded ClamShell</p> <p>R : ReverseLock</p> <p>T : SlimLock</p>		<p><b>Grid code / Config. code</b></p> <p>Will be given by the factory after receipt of the chip datasheet</p>		

# Probe Pin Solderless Compression Test Socket

For BGA / Bumped chip / WLCSP / eMMC Package

0.50 mm pitch (from 0.50 mm to 0.79 mm)

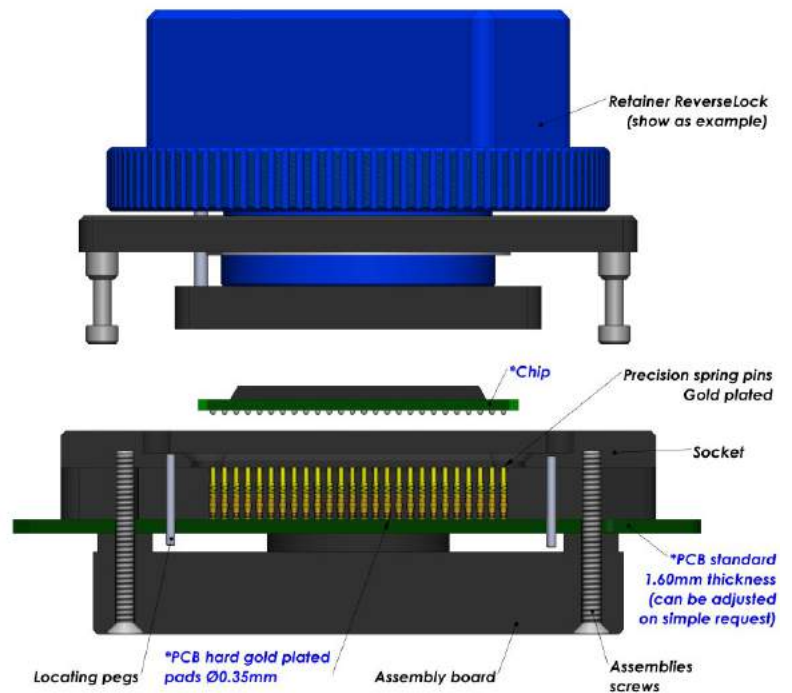
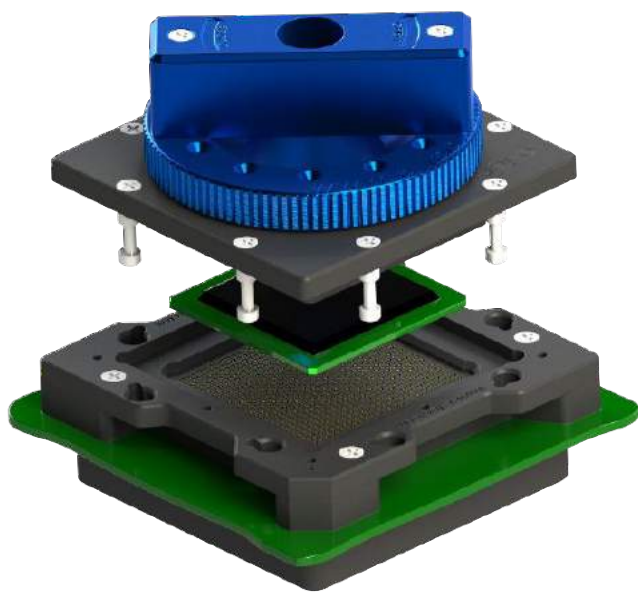

**E-tec Interconnect AG is the world leading Test socket manufacturer**

Probe Pin (Pogo) Solderless compression Test Sockets type are available for any chip size and pitch and are attached with 2, 4 or 8 screws to the PCB. The assembly board ensures perfect coplanarity of the socket. Contact reliability is guaranteed with spring loaded gold plated contacts, which are pressed onto gold plated PCB pads. Probe Pin (Pogo) Solderless compression type sockets are available with all retention systems. We aim to solve your requirements. Please note, we will always request the chip data to ensure we offer a compatible socket.

Contacts Specifications						
Contact type code	0590	0591	0592	0593	0594	0598
Application	Standard	Long live	High Frequency	High Temp & Long live	High Power	SuperHigh Frequency
Mounting	Solderless	Solderless	Solderless	Solderless	Solderless	Solderless
Bandwidth (GHz@-1dB)	3 GHz	7 GHz	29 GHz	8.9 GHz	9 GHz	40 GHz
Contact resistance	<100 mOhm	40 mOhm	100 mOhm	80 mOhm	80 mOhm	100 mOhm
Chip contact tip shape	Single Point tip Concave tip	Crown tip	Single Point tip	Crown tip	Crown tip	Single Point tip
PCB tip shape	Single Point tip	Single Point tip	Single Point tip	Single Point tip	Single Point tip	Spring
Force	30 gr	23 gr	20 gr	23 gr	30 gr	20 gr
Current rating	1.5 A	1 A	1.5 A	2 A	2 A	0.5 A
Capacitance pF	<1 pF	0.45 pF	0.48 pF	0.71 pF	na	0.36 pF
Inductance nH	<2 nH	1.08 nH	0.89 nH	0.67 nH	na	1.19 nH
Impedance Ohms	38 Ω	39 Ω	38 Ω	55 Ω	60 Ω	62 Ω
Temperature range	-55°C to +150°C	-50°C to +150°C	-40°C to +120°C	-50°C to +220°C	-50°C to +220°C	-55°C to +150°C
Mating cycles	100 K	300 K	100 K	500 K	500 K	100 K

More on the next page





# Probe Pin Solderless Compression Test Socket

For BGA / Bumped chip / WLCSP / eMMC Package

0.50 mm pitch (from 0.50 mm to 0.79 mm)

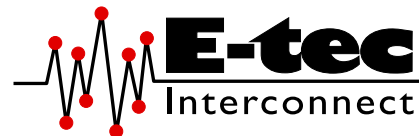

## Standard assembly boards

Small Chip size



Medium Chip size

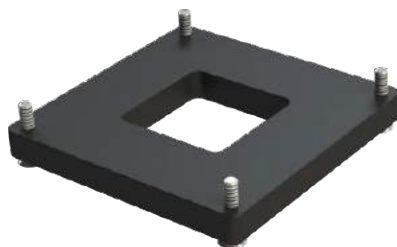

Large Chip size



## Custom assembly boards

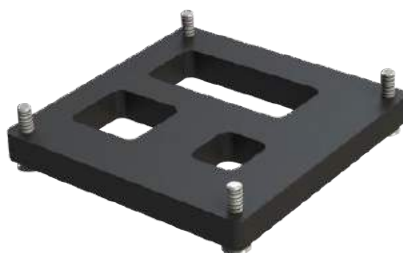
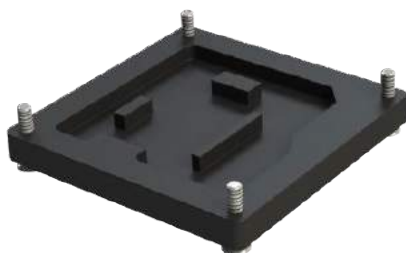

## How to order

**BU # # # # # -059# - # # # # # # 55L #**

<p><b>Shape of tip</b></p> <p>U : Concave</p> <p><b>Options:</b></p> <p>P : Pointed</p> <p>S : Spring</p> <p>C : Crown</p>	<p><b>Nbr of contacts</b></p> <p>Depends on ballcount of chip</p>	<p><b>Contact type</b></p> <p>91 to 98 : See "Contacts specification" chart</p> <p>90 : Standard solderless compression style</p> <p>9M : Special mixed contact style</p>	<p><b>Plating</b></p> <p>55L: Gold + Locating pegs</p> <p>Other on request</p>	<p><b>Option code</b> (see page 16-19)</p> <p>D : Dead bug</p> <p>M : Multi frames</p> <p>U : Multi packages</p> <p>S : Custom opening slot</p> <p>H : Heatsink</p> <p>F : Fan + Heatsink</p> <p>P : Thermal drain pad</p> <p>W : Transparent lid</p> <p>I : Steel retention lid</p> <p>B : Aluminium retention lid</p> <p>T : Torque tool fixture</p> <p>G : Handling button</p>
<p><b>Retention frame type (Lid)</b> (see page 12-15)</p> <p>W: TwistLock</p> <p>F : FastLock</p> <p>B : SpringLock</p> <p>H : Open Clamshell Alu (&lt;200 contacts)</p> <p>J : Clamshell Alu (&gt;200 contacts)</p> <p>L : Open Lever Clamshell Alu (&gt;200 contacts)</p> <p>S : ScrewLock</p> <p>Q : Open QuickLock (&lt;200 contacts)</p> <p>D : QuickLock (&gt;200 contacts)</p> <p>M : Injection Molded ClamShell</p> <p>R : ReverseLock</p> <p>T : SlimLock</p>		<p><b>Grid code / Config. code</b></p> <p>Will be given by the factory after receipt of the chip datasheet</p>		



# Elastomer Solderless Compression Test Socket

For BGA / Bumped chip / WLCSP / eMMC Package e

0.50 mm pitch (from 0.50mm to 0.79mm)

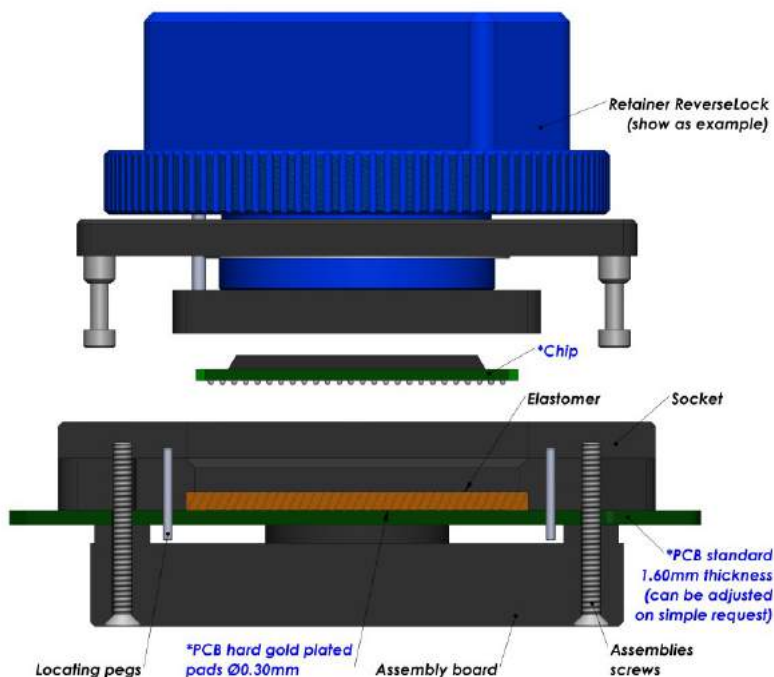
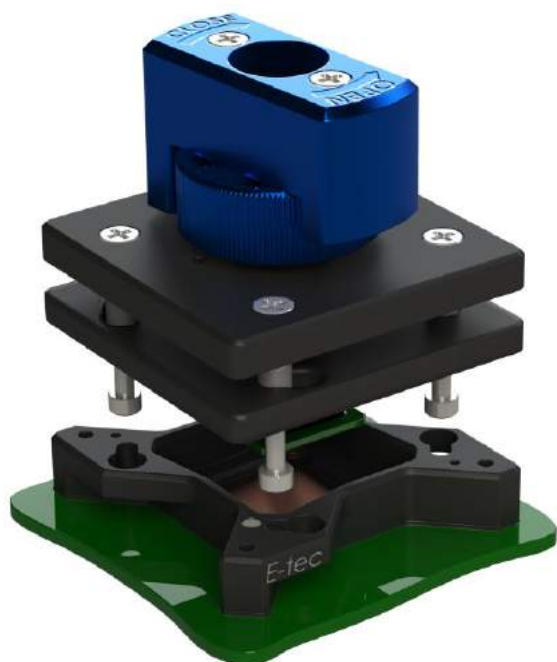
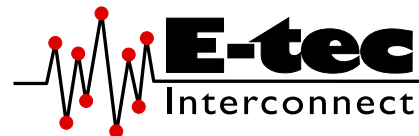

## E-tec Interconnect AG is the world leading Test socket manufacturer

The Elastomer Solderless compression Test Sockets are ideal technical solution for good signal integrity with low signal loss. The sockets are available for any chip size and pitch and are attached with 2, 4 or 8 screws to the PCB. The socket outline will be kept to a minimum and special clearances can be offered to avoid components on the PCB.

SMT and thru-hole adapter sockets are available in certain pitches (contact factory for availability first) with these elastomer interposers to allow using this high frequency interposer on PCB's which have already been laid out for SMT or thru-hole sockets. We aim to solve your requirements. Please note, we will always request the chip data to ensure we offer a compatible socket.

Contacts Specifications			
Contact type code	E1	E2	E3
Application	High Frequency		
Mounting	Solderless	Solderless	Solderless
Bandwidth (GHz@-1dB)	17 GHz	34 GHz	>40 GHz
Contact resistance	30 mOhm		
Chip contact tip shape	Gold Wire		
PCB tip shape	Gold Wire		
Force	20 gr to 50 gr		
Current rating	2.5 A		
Capacitance pF	0.14 pF	0.10 pF	0.06 pF
Inductance nH	0.23 nH	0.30 nH	0.03 nH
Impedance Ohms	41.3 Ω	47.1 Ω	51.1 Ω
Temperature range	-40°C to +125°C		
Mating cycles	1 K		

More on the next page



# Elastomer Solderless Compression Test Socket

For BGA / Bumped chip / WLCSP / eMMC Package e

0.50 mm pitch (from 0.50mm to 0.79mm)



## Standard assembly boards

Small Chip size



Medium Chip size

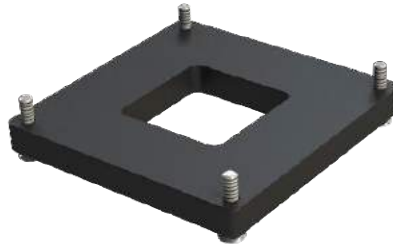

Large Chip size



## Custom assembly boards

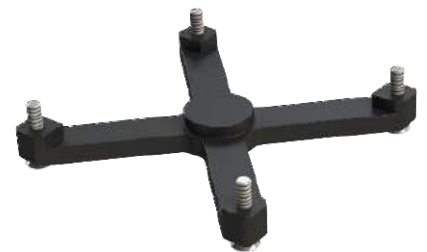
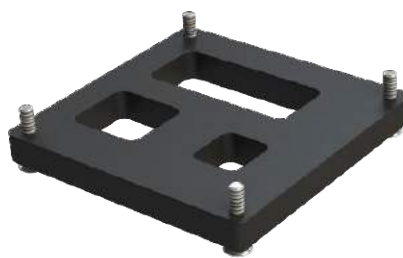
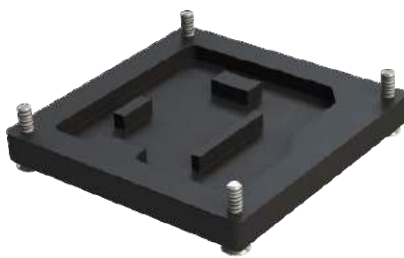

## How to order

**BE# #### -05E# - ##### 55L #**

**Shape of tip**

E : Elastomer

**Nbr of contacts**

Depends on ballcount of chip

**Contact type**

E1 : High Frequency 17 GHz  
E2 : High Frequency 34 GHz  
E3 : High Frequency 40 GHz

**Plating**

55L: Gold + Locating pegs

**Option code** (see page 16-19)

M : Multi frames  
U : Multi packages  
S : Custom opening slot  
H : Heatsink  
F : Fan + Heatsink  
W : Transparent lid  
I : Steel retention lid  
B : Aluminium retention lid  
G : Handling button

**Retention frame type (Lid)** (see page 12-15)

W: TwistLock  
F : FastLock  
B : SpringLock  
H : Open Clamshell Alu (<200 contacts)  
J : Clamshell Alu (>200 contacts)  
L : Open Lever Clamshell Alu (>200 contacts)  
S : ScrewLock  
Q : Open QuickLock (<200 contacts)  
D : QuickLock (>200 contacts)  
M : Injection Molded ClamShell  
R : ReverseLock  
T : SlimLock

**Grid code / Config. code**

Will be given by the factory after receipt of the chip datasheet







# Through-hole (THT) soldering Test Socket

For BGA / Bumped chip / WLCSP / eMMC Package

0.80 mm pitch (from 0.80 mm up to 0.99 mm)

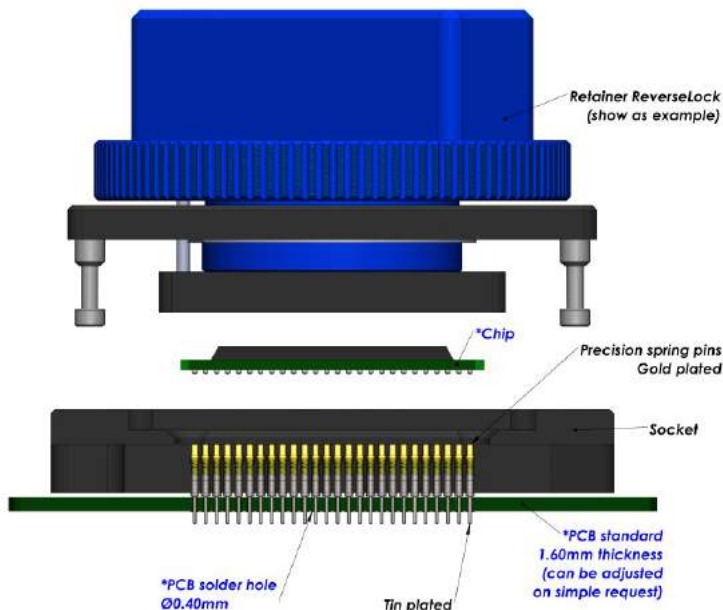
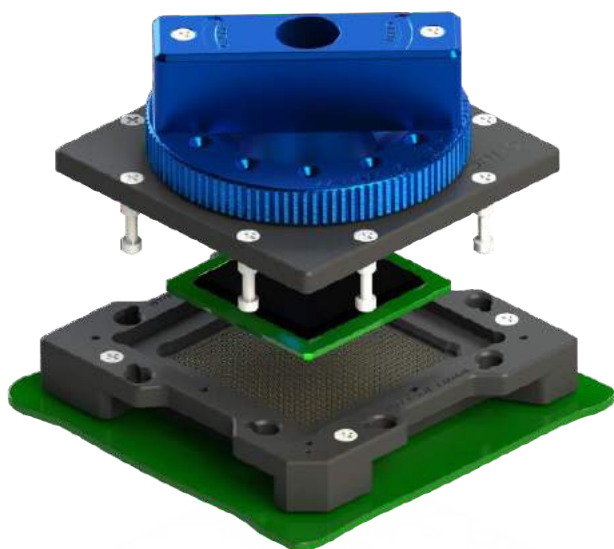
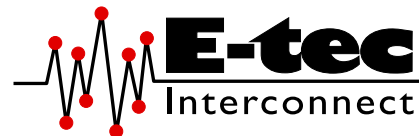

**E-tec Interconnect AG is the world leading Test socket manufacturer**

The Through-hole socket uses the same footprint as your chip. Socket is simply placed and wave soldered onto the PCB in the same way as the chip and it only requires a small amount of additional board space. Through-hole sockets are available with all retention systems. Please note, we will always request the chip data to ensure we offer a compatible socket.

Specifications contact type code 0870			
Application	Through-hole technology	Force	30 gr
Mounting	THT	Current rating	1.8 A
Bandwidth (GHz@-1dB)	3.4 GHz	Capacitance pF	0.59 pF
Contact resistance	<100mOhm	Inductance nH	1.70 nH
Chip contact tip shape	Single Point tip or Concave tip	Temperature range	-55°C to +150°C
PCB tip shape	Through-hole	Mating cycles	100 K

## How to order

**BU # #### -087# - ##### #5 #**

<p><b>Shape of tip</b></p> <p>U : Concave</p> <p><b>Options:</b></p> <p>P : Pointed</p> <p>S : Spring</p> <p>C : Crown</p>	<p><b>Nbr of contacts</b></p> <p>Depends on ballcount of chip</p>	<p><b>Contact type</b></p> <p>70 : Standard THT</p> <p>72 : Special THT to plug into MGS adapters</p>	<p><b>Plating</b></p> <p>95: Tin / Gold</p> <p>55: Gold / Gold</p> <p>Other on request</p>	<p><b>Option code</b> (see page 16-19)</p> <p>D : Dead bug</p> <p>M : Multi frames</p> <p>U : Multi packages</p> <p>S : Custom opening slot</p> <p>L : Locating pegs</p> <p>A : Alignment plate</p> <p>H : Heatsink</p> <p>F : Fan + Heatsink</p> <p>P : Thermal drain pad</p> <p>W : Transparent lid</p> <p>I : Steel retention lid</p> <p>B : Aluminium retention lid</p> <p>T : Torque tool fixture</p> <p>G : Handling button</p>
<p><b>Retention frame type (Lid)</b> (see page 12-15)</p> <p>W: TwistLock</p> <p>F : FastLock</p> <p>B : SpringLock</p> <p>H : Open Clamshell Alu (&lt;200 contacts)</p> <p>J : Clamshell Alu (&gt;200 contacts)</p> <p>L : Open Lever Clamshell Alu (&gt;200 contacts)</p>		<p><b>Grid code / Config. code</b></p> <p>Will be given by the factory after receipt of the chip datasheet</p>		
		<p>S : ScrewLock</p> <p>Q : Open QuickLock (&lt;200 contacts)</p> <p>D : QuickLock (&gt;200 contacts)</p> <p>M : Injection Molded ClamShell</p> <p>R : ReverseLock</p> <p>T : SlimLock</p>		



# Standard SMT soldering Test Socket

For BGA / Bumped chip / WLCSP / eMMC Package  
**0.80 mm pitch** (from 0.80 mm up to 0.99 mm)

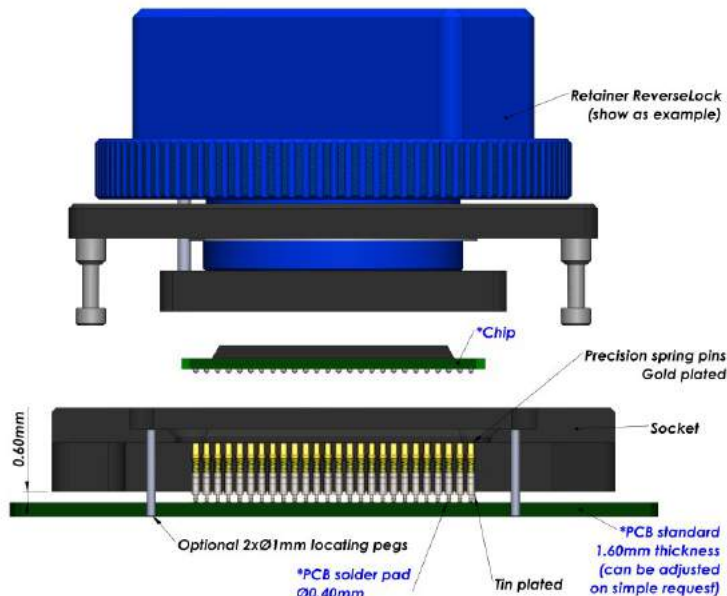
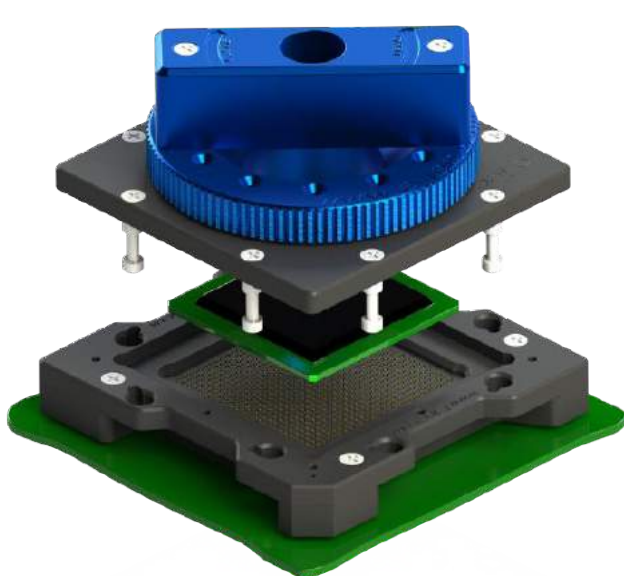
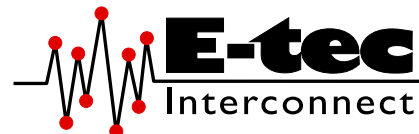

**E-tec Interconnect AG is the world leading Test socket manufacturer**

The SMT socket uses the same footprint as your chip. Socket is simply placed and reflowed onto the PCB in the same way as the chip and it only requires a small amount of additional board space. SMT type sockets are available with all retention systems. We aim to solve your requirements. Please note, we will always request the chip data to ensure we offer a compatible socket. For SMT sockets in general, E-tec Interconnect AG recommends the use of locating pegs, which can be soldered to the PCB for added mechanical strength.

Specifications contact type code 0830			
Application	Surface mouting	Force	30 gr
Mounting	SMT	Current rating	1.8 A
Bandwidth (GHz@-1dB)	2.6(4.4) GHz	Capacitance pF	0.59 pF
Contact resistance	<100mOhm	Inductance nH	1.70 nH
Chip contact tip shape	Single Point tip or Concave tip	Temperature range	-55°C to +150°C
PCB tip shape	SMT	Mating cycles	100K

## How to order

**BU # #### -0830 - ##### 95 #**

<p><b>Shape of tip</b></p> <p>U : Concave</p> <p><b>Options:</b></p> <p>P : Pointed</p> <p>S : Spring</p> <p>C : Crown</p>	<p><b>Nbr of contacts</b></p> <p>Depends on ballcount of chip</p>	<p><b>Contact type</b></p> <p>30 : Standard SMT – Dimension A = 0.60 mm</p>	<p><b>Plating</b></p> <p>95 : Tin / Gold</p> <p>Other on request</p>	<p><b>Option code</b> (see page 16-19)</p> <p>D : Dead bug</p> <p>M : Multi frames</p> <p>U : Multi packages</p> <p>S : Custom opening slot</p> <p>L : Locating pegs</p> <p>H : Heatsink</p> <p>F : Fan + Heatsink</p> <p>P : Thermal drain pad</p> <p>W : Transparent lid</p> <p>I : Steel retention lid</p> <p>B : Aluminium retention lid</p> <p>G : Handling button</p>
<p><b>Retention frame type (Lid)</b> (see page 12-15)</p> <p>W : TwistLock</p> <p>F : FastLock</p> <p>B : SpringLock</p> <p>H : Open Clamshell Alu (&lt;200 contacts)</p> <p>J : Clamshell Alu (&gt;200 contacts)</p> <p>L : Open Lever Clamshell Alu (&gt;200 contacts)</p>		<p><b>Grid code / Config. code</b></p> <p>Will be given by the factory after receipt of the chip datasheet</p>		
		<p>S : ScrewLock</p> <p>Q : Open QuickLock (&lt;200 contacts)</p> <p>D : QuickLock (&gt;200 contacts)</p> <p>M : Injection Molded ClamShell</p> <p>R : ReverseLock</p> <p>T : SlimLock</p>		



# Raised SMT soldering Test Socket

For BGA / Bumped chip / WLCSP / eMMC Package  
**0.80 mm pitch** (from 0.80 mm up to 0.99 mm)

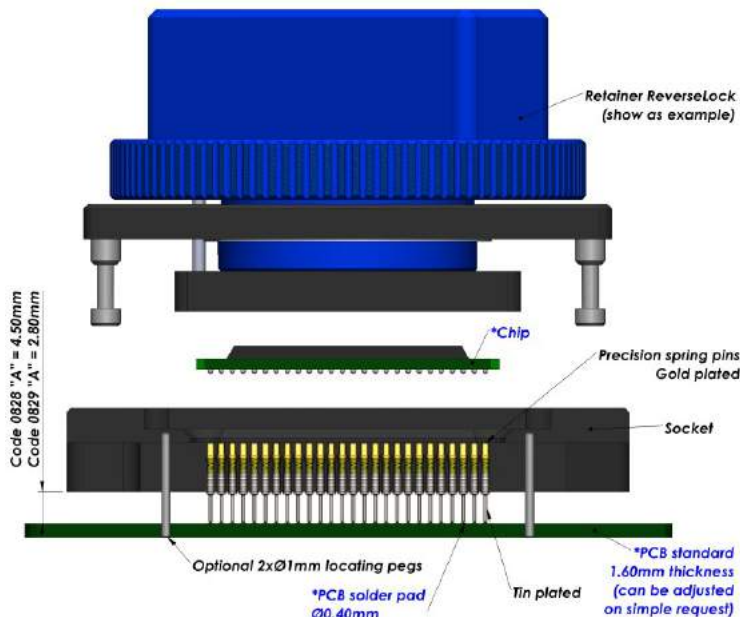
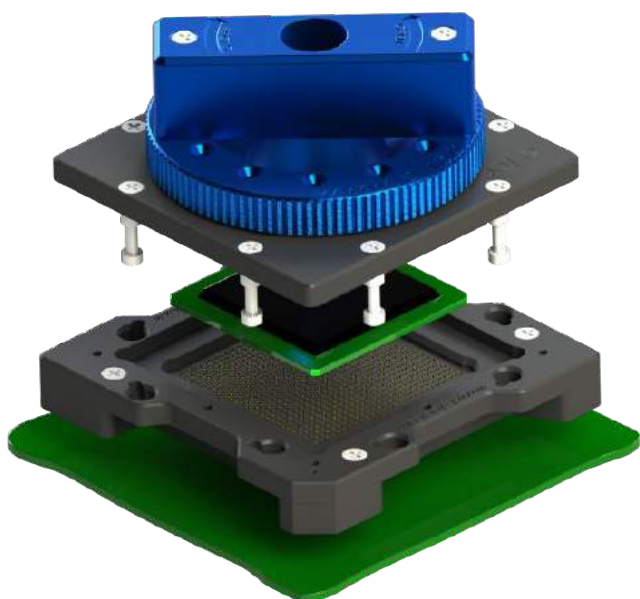
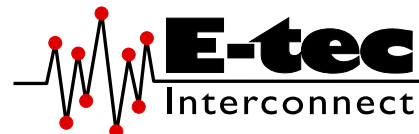

## E-tec Interconnect AG is the world leading Test socket manufacturer

The Raised SMT socket lifts the socket above close-by components on PCB and uses the same footprint as your chip. Socket is simply placed and reflowed onto the PCB in the same way as the chip and it only requires a small amount of additional board space. Raised SMT sockets are available with all retention systems. We aim to solve your requirements. Please note, we will always request the chip data to ensure we offer a compatible socket. For Raised SMT sockets in general, E-tec Interconnect AG recommends the use of locating pegs, which can be soldered to the PCB for added mechanical strength.

Specifications contact type code 0829 & 0828			
Application	Surface mouting	Force	30 gr
Mounting	Raised SMT	Current rating	1.8 A
Bandwidth (GHz@-1dB)	na	Capacitance pF	na
Contact resistance	<100mOhm	Inductance nH	na
DUT Contact tip shape	Single Point tip or Concave tip	Temperature range	-55°C to +150°C
PCB tip shape	Raised SMT	Mating cycles	100 K

## How to order

**BU # #### -082# - ##### 95A #**

**Shape of tip**  
**U** : Concave  
**Options:**  
**P** : Pointed  
**S** : Spring  
**C** : Crown

**Nbr of contacts**  
 Depends on ballcount of chip

**Contact type**  
**29** : Raised SMT – Dimension A = 2.80 mm  
**28** : Special Raised SMT - Dim. A = 4.50 mm

**Plating**  
**95A**: Tin/Gold + Alignment plate  
 Other on request

**Option code** (see page 16-19)  
**D** : Dead bug  
**M** : Multi frames  
**U** : Multi packages  
**S** : Custom opening slot  
**L** : Locating pegs  
**H** : Heatsink  
**F** : Fan + Heatsink  
**P** : Thermal drain pad  
**W** : Transparent lid  
**I** : Steel retention lid  
**B** : Aluminium retention lid  
**T** : Torque tool fixture  
**G** : Handling button

**Retention frame type (Lid)** (see page 12-15)  
**W**: TwistLock  
**F**: FastLock  
**B**: SpringLock  
**H**: Open Clamshell Alu (<200 contacts)  
**J**: Clamshell Alu (>200 contacts)  
**L**: Open Lever Clamshell Alu (>200 contacts)  
**S**: ScrewLock  
**Q**: Open QuickLock (<200 contacts)  
**D**: QuickLock (>200 contacts)  
**M**: Injection Molded ClamShell  
**R**: ReverseLock  
**T**: SlimLock

**Grid code / Config. code**  
 Will be given by the factory after receipt of the chip datasheet



# Probe Pin Solderless Compression Test Socket

For BGA / Bumped chip / WLCSP / eMMC Package

0.80 mm pitch (from 0.80 mm to 0.99 mm)

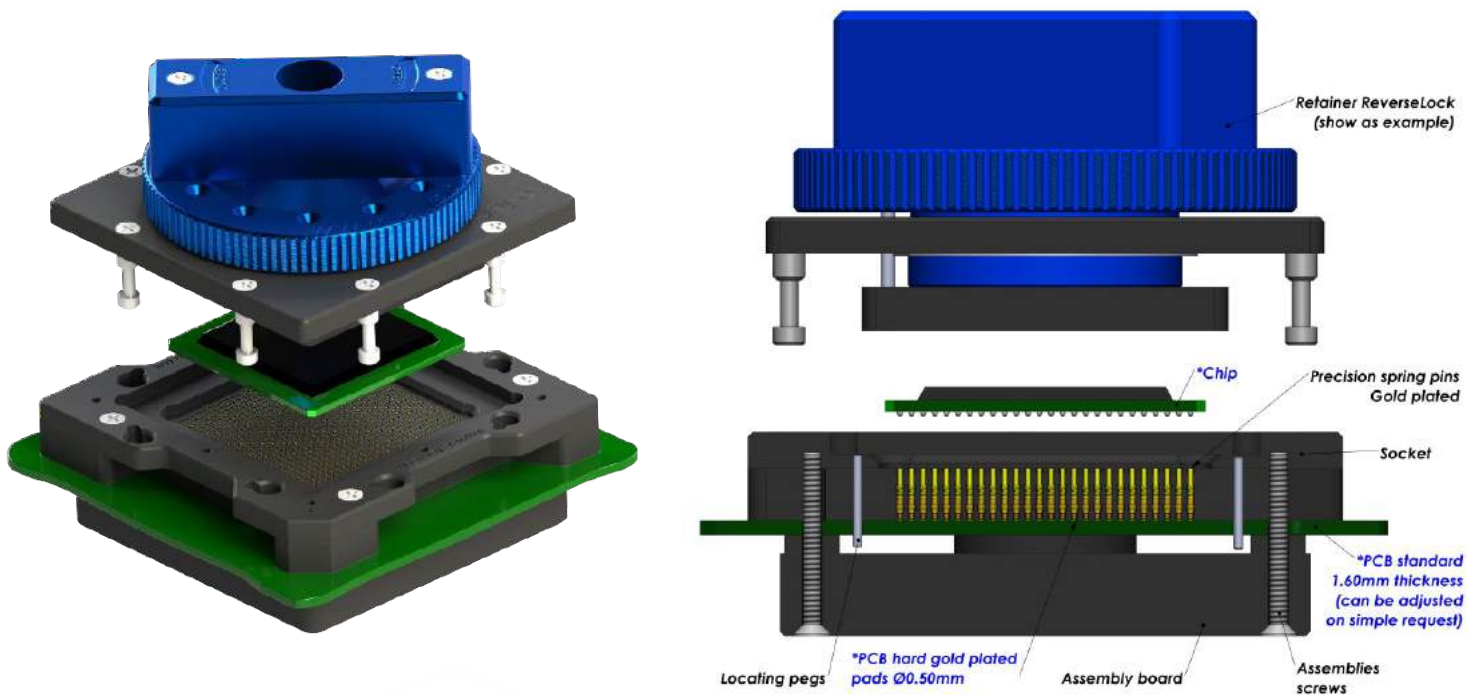

**E-tec Interconnect AG is the world leading Test socket manufacturer**

Probe Pin (Pogo) Solderless compression Test Sockets type are available for any chip size and pitch and are attached with 2, 4 or 8 screws to the PCB. The assembly board ensures perfect coplanarity of the socket. Contact reliability is guaranteed with spring loaded gold plated contacts, which are pressed onto gold plated PCB pads. Probe Pin (Pogo) Solderless compression type sockets are available with all retention systems. We aim to solve your requirements. Please note, we will always request the chip data to ensure we offer a compatible socket.

Contacts Specifications						
Contact type code	0890	0891	0893	0892	0894	0898
Application	Standard	High Frequency	Low Contact Resistance	High Frequency	Frequency	Frequency
Mounting	Solderless	Solderless	Solderless	Solderless	Solderless	Solderless
Bandwidth (GHz@-1dB)	3.4 GHz	36 GHz	7 GHz	31 GHz	14 GHz	31.7 GHz
Contact resistance	<100 mOhm	100 mOhm	40 mOhm	90 mOhm	90 mOhm	25 mOhm
Chip contact tip shape	Single Point tip Concave tip	Single Point tip	Crown tip	Single Point tip	Single Point tip	Single Point tip
PCB tip shape	Single Point tip	Single Point tip	Single Point tip	Spring	Spring	Spring
Force	30 gr	33 gr	23 gr	20 gr	20 gr	25 gr
Current rating	1.8 A	1 A	1 A	0.5 A	0.5 A	2.6 A
Capacitance pF	<1 pF	0.47 pF	0.55 pF	0.37 pF	0.30 pF	0.60 pF
Inductance nH	<2 nH	0.93 nH	1.08 nH	1.67 nH	1.66 nH	1.38 nH
Impedance Ohms	40 Ω	38 Ω	39 Ω	73 Ω	78 Ω	44.8 Ω
Temperature range	-55°C to +150°C	-40°C to +120°C	-50°C to +150°C	-55°C to +150°C	-55°C to +150°C	-55°C to +150°C
Mating cycles	100 K	100 K	100 K	100 K	100 K	100 K

More on the next page





# Probe Pin Solderless Compression Test Socket

For BGA / Bumped chip / WLCSP / eMMC Package

0.80 mm pitch (from 0.80 mm to 0.99 mm)

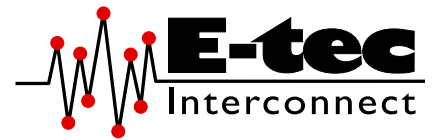

## Standard assembly boards

### Small Chip size



### Medium Chip size

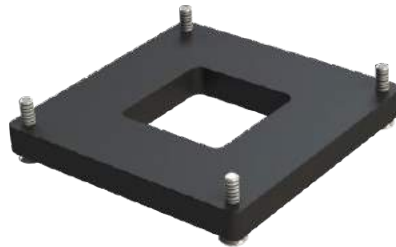

### Large Chip size



## Custom assembly boards

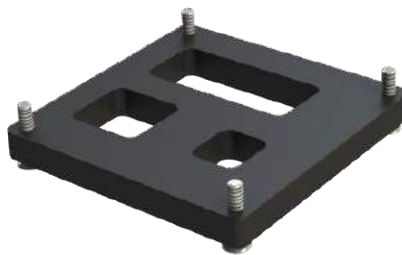
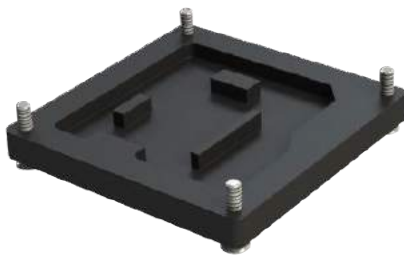

## How to order

**BU # # # # # -089# - # # # # # 55L #**

<p><b>Shape of tip</b></p> <p>U : Concave</p> <p><b>Options:</b></p> <p>P : Pointed</p> <p>S : Spring</p> <p>C : Crown</p>	<p><b>Nbr of contacts</b></p> <p>Depends on ballcount of chip</p>	<p><b>Contact type</b></p> <p>91 to 98 : See "Contacts specification" chart</p> <p>90 : Standard solderless compression style</p> <p>9M: Special mixed contact style</p>	<p><b>Plating</b></p> <p>55L: Gold + Locating pegs</p> <p>Other on request</p>	<p><b>Option code</b> (see page 16-19)</p> <p>D : Dead bug</p> <p>M : Multi frames</p> <p>U : Multi packages</p> <p>S : Custom opening slot</p> <p>H : Heatsink</p> <p>F : Fan + Heatsink</p> <p>P : Thermal drain pad</p> <p>W: Transparent lid</p> <p>I : Steel retention lid</p> <p>B : Aluminium retention lid</p> <p>T : Torque tool fixture</p> <p>G : Handling button</p>
<p><b>Retention frame type (Lid)</b> (see page 12-15)</p> <p>W: TwistLock</p> <p>F : FastLock</p> <p>B : SpringLock</p> <p>H : Open Clamshell Alu (&lt;200 contacts)</p> <p>J : Clamshell Alu (&gt;200 contacts)</p> <p>L : Open Lever Clamshell Alu (&gt;200 contacts)</p> <p>S : ScrewLock</p> <p>Q : Open QuickLock (&lt;200 contacts)</p> <p>D : QuickLock (&gt;200 contacts)</p> <p>M: Injection Molded ClamShell</p> <p>R : ReverseLock</p> <p>T : SlimLock</p>		<p><b>Grid code / Config. code</b></p> <p>Will be given by the factory after receipt of the chip datasheet</p>		





# Elastomer Solderless Compression Test Socket

For BGA / Bumped chip / WLCSP / eMMC Package

0.80 mm pitch (from 0.80 mm to 0.99 mm)

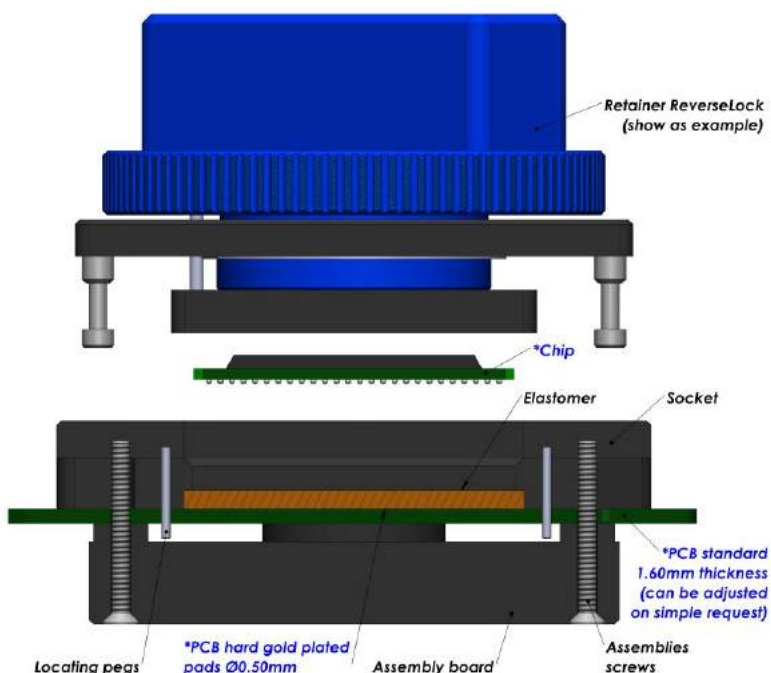
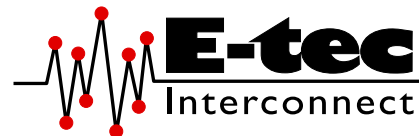

## E-tec Interconnect AG is the world leading Test socket manufacturer

The Elastomer Solderless compression Test Sockets are ideal technical solution for good signal integrity with low signal loss. The sockets are available for any chip size and pitch and are attached with 2, 4 or 8 screws to the PCB. The socket outline will be kept to a minimum and special clearances can be offered to avoid components on the PCB.

SMT and thru-hole adapter sockets are available in certain pitches (contact factory for availability first) with these elastomer interposers to allow using this high frequency interposer on PCB's which have already been laid out for SMT or thru-hole sockets. We aim to solve your requirements. Please note, we will always request the chip data to ensure we offer a compatible socket.

Contacts Specifications		
Contact type code	E1	E2
Application	High Frequency	
Mounting	Solderless	Solderless
Bandwidth (GHz@-1dB)	23 GHz	24 GHz
Contact resistance	30 mOhm	
Chip contact tip shape	Gold Wire	
PCB tip shape	Gold Wire	
Force	20 gr to 50 gr	
Current rating	3 A	
Capacitance pF	0.26 pF	0.16 pF
Inductance nH	0.52 nH	0.26 nH
Impedance Ohms	44.8 Ω	44.4 Ω
Temperature range	-40°C to +125°C	
Mating cycles	1 K	

More on the next page



# Elastomer Solderless Compression Test Socket

For BGA / Bumped chip / WLCSP / eMMC Package

0.80 mm pitch (from 0.80 mm to 0.99 mm)

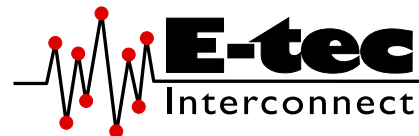

## Standard assembly boards

Small Chip size



Medium Chip size

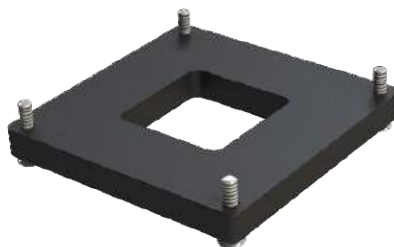

Large Chip size

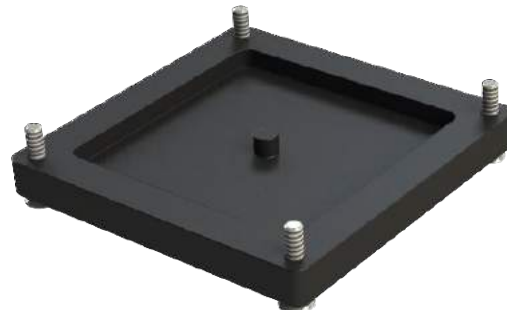

## Custom assembly boards

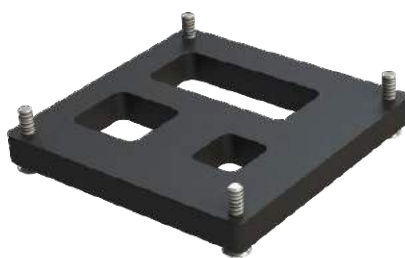
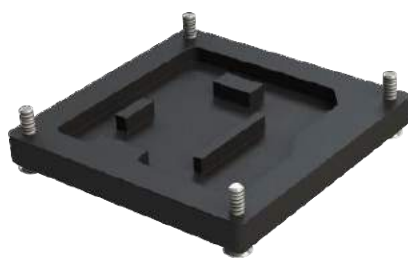

## How to order

**BE# #### -08E# - ##### 55L #**

<p><b>Shape of tip</b> E : Elastomer</p>	<p><b>Nbr of contacts</b> Depends on ballcount of chip</p>	<p><b>Contact type</b> E1 : High Frequency 23 GHz E2 : High Frequency 24 GHz</p>	<p><b>Plating</b> 55L: Gold + Locating pegs</p>	<p><b>Option code</b> (see page 16-19) M : Multi frames U : Multi packages S : Custom opening slot H : Heatsink F : Fan + Heatsink W : Transparent lid I : Steel retention lid B : Aluminium retention lid G : Handling button</p>
<p><b>Retention frame type (Lid)</b> (see page 12-15)</p> <p>W : TwistLock F : FastLock B : SpringLock H : Open Clamshell Alu (&lt;200 contacts) J : Clamshell Alu (&gt;200 contacts) L : Open Lever Clamshell Alu (&gt;200 contacts)</p> <p>S : ScrewLock Q : Open QuickLock (&lt;200 contacts) D : QuickLock (&gt;200 contacts) M : Injection Molded ClamShell R : ReverseLock T : SlimLock</p>		<p><b>Grid code / Config. code</b> Will be given by the factory after receipt of the chip datasheet</p>		





# Through-hole (THT) soldering Test Socket

For BGA / Bumped chip / WLCSP / eMMC Package

1.00 mm pitch (from 1.00 mm up to 1.26 mm)

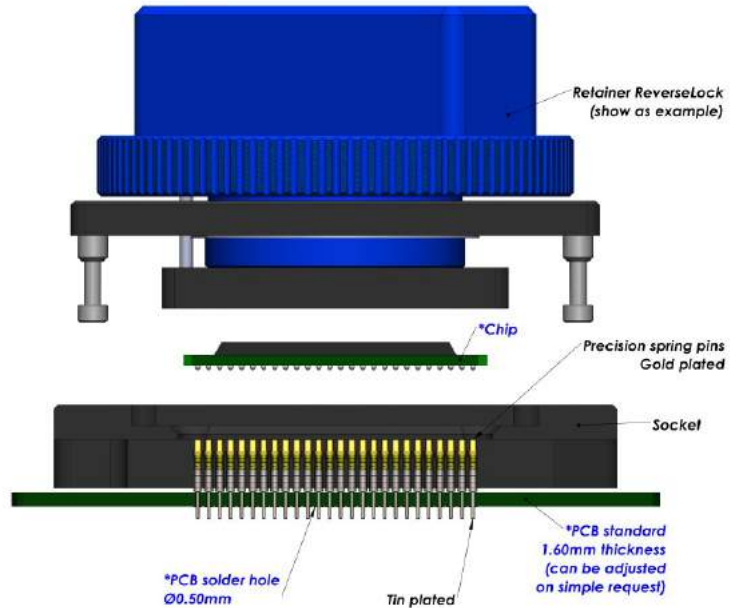
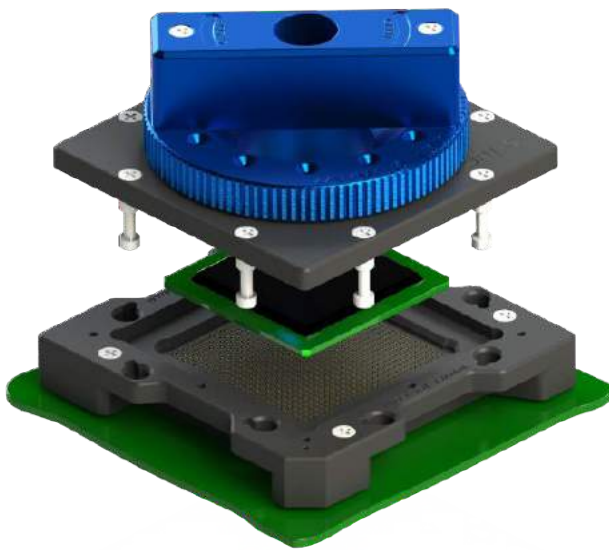

**E-tec Interconnect AG is the world leading Test socket manufacturer**

The Through-hole socket uses the same footprint as your chip. Socket is simply placed and wave soldered onto the PCB in the same way as the chip and it only requires a small amount of additional board space. Through-hole sockets are available with all retention systems. Please note, we will always request the chip data to ensure we offer a compatible socket.

Specifications contact type code 1070			
Application	Through-hole technology	Force	25 gr
Mounting	THT	Current rating	1.8 A
Bandwidth (GHz@-1dB)	3.4 GHz	Capacitance pF	1.03 pF
Contact resistance	<100mOhm	Inductance nH	1.80 nH
Chip contact tip shape	Single Point tip or Concave tip	Temperature range	-55°C to +150°C
PCB tip shape	Through-hole	Mating cycles	100 K

## How to order

**BU # #### -107# - ##### #5 #**

<p><b>Shape of tip</b></p> <p>U : Concave</p> <p><b>Options:</b></p> <p>P : Pointed</p> <p>S : Spring</p> <p>C : Crown</p>	<p><b>Nbr of contacts</b></p> <p>Depends on ballcount of chip</p>	<p><b>Contact type</b></p> <p>70 : Standard THT</p> <p>72 : Special THT to plug into MGS adapters</p>	<p><b>Plating</b></p> <p>95: Tin / Gold</p> <p>55: Gold / Gold</p> <p>Other on request</p>	<p><b>Option code</b> (see page 16-19)</p> <p>D : Dead bug</p> <p>M : Multi frames</p> <p>U : Multi packages</p> <p>S : Custom opening slot</p> <p>L : Locating pegs</p> <p>A : Alignment plate</p> <p>H : Heatsink</p> <p>F : Fan + Heatsink</p> <p>P : Thermal drain pad</p> <p>W : Transparent lid</p> <p>I : Steel retention lid</p> <p>B : Aluminium retention lid</p> <p>T : Torque tool fixture</p> <p>G : Handling button</p>
<p><b>Retention frame type (Lid)</b> (see page 12-15)</p> <p>W: TwistLock</p> <p>F : FastLock</p> <p>B : SpringLock</p> <p>H : Open Clamshell Alu (&lt;200 contacts)</p> <p>J : Clamshell Alu (&gt;200 contacts)</p> <p>L : Open Lever Clamshell Alu (&gt;200 contacts)</p>		<p><b>Grid code / Config. code</b></p> <p>Will be given by the factory after receipt of the chip datasheet</p>		<p>S : ScrewLock</p> <p>Q : Open QuickLock (&lt;200 contacts)</p> <p>D : QuickLock (&gt;200 contacts)</p> <p>M : Injection Molded ClamShell</p> <p>R : ReverseLock</p> <p>T : SlimLock</p>



# Standard SMT soldering Test Socket

For BGA / Bumped chip / WLCSP / eMMC Package  
**1.00 mm pitch** (from 1.00 mm up to 1.26 mm)

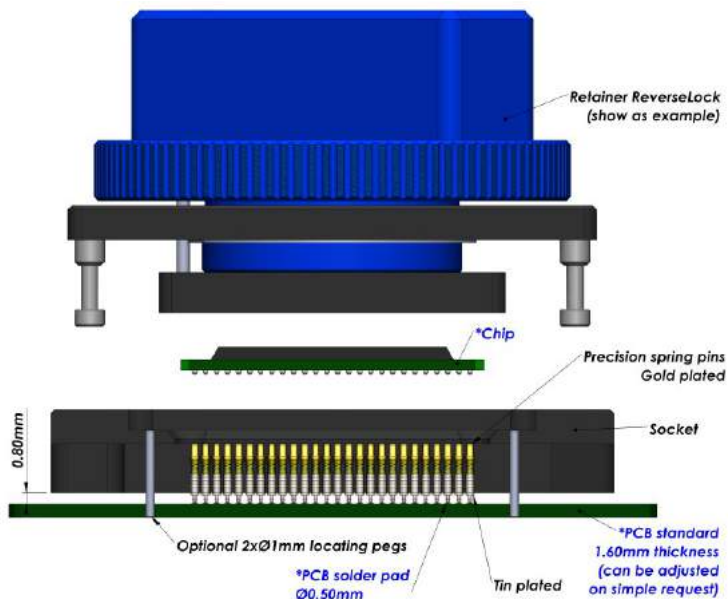
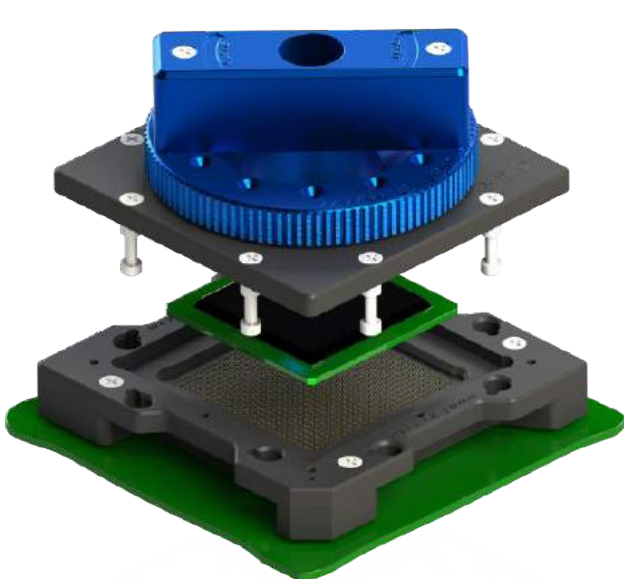
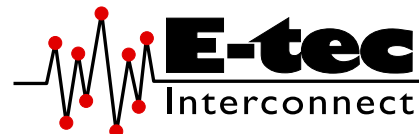

**E-tec Interconnect AG is the world leading Test socket manufacturer**

The SMT socket uses the same footprint as your chip. Socket is simply placed and reflowed onto the PCB in the same way as the chip and it only requires a small amount of additional board space. SMT type sockets are available with all retention systems. We aim to solve your requirements. Please note, we will always request the chip data to ensure we offer a compatible socket. For SMT sockets in general, E-tec Interconnect AG recommends the use of locating pegs, which can be soldered to the PCB for added mechanical strength.

Specifications contact type code 1030			
<b>Application</b>	Surface mouting	<b>Force</b>	25 gr
<b>Mounting</b>	SMT	<b>Current rating</b>	1.8 A
<b>Bandwidth (GHz@-1dB)</b>	2.8(6.6) GHz	<b>Capacitance pF</b>	0.62 pF
<b>Contact resistance</b>	<100mOhm	<b>Inductance nH</b>	1.97 nH
<b>Chip contact tip shape</b>	Single Point tip or Concave tip	<b>Temperature range</b>	-55°C to +150°C
<b>PCB tip shape</b>	SMT	<b>Mating cycles</b>	100 K

## How to order

**BU # #### -1030 - ##### 95 #**

### Shape of tip

**U** : Concave

#### Options:

- P** : Pointed
- S** : Spring
- C** : Crown

### Nbr of contacts

Depends on ballcount of chip

### Contact type

**30** : Standard SMT – Dimension A = 0.80 mm

### Plating

**95** : Tin / Gold  
Other on request

### Option code (see page 16-19)

- D** : Dead bug
- M** : Multi frames
- U** : Multi packages
- S** : Custom opening slot
- L** : Locating pegs
- H** : Heatsink
- F** : Fan + Heatsink
- P** : Thermal drain pad
- W** : Transparent lid
- I** : Steel retention lid
- B** : Aluminium retention lid
- G** : Handling button

### Retention frame type (Lid) (see page 12-15)

- W** : TwistLock
- F** : FastLock
- B** : SpringLock
- H** : Open Clamshell Alu (<200 contacts)
- J** : Clamshell Alu (>200 contacts)
- L** : Open Lever Clamshell Alu (>200 contacts)
- S** : ScrewLock
- Q** : Open QuickLock (<200 contacts)
- D** : QuickLock (>200 contacts)
- M** : Injection Molded ClamShell
- R** : ReverseLock
- T** : SlimLock

### Grid code / Config. code

Will be given by the factory after receipt of the chip datasheet





**Raised SMT soldering Test Socket**  
 For BGA / Bumped chip / WLCSP / eMMC Package  
**1.00 mm pitch** (from 1.00 mm up to 1.26 mm)

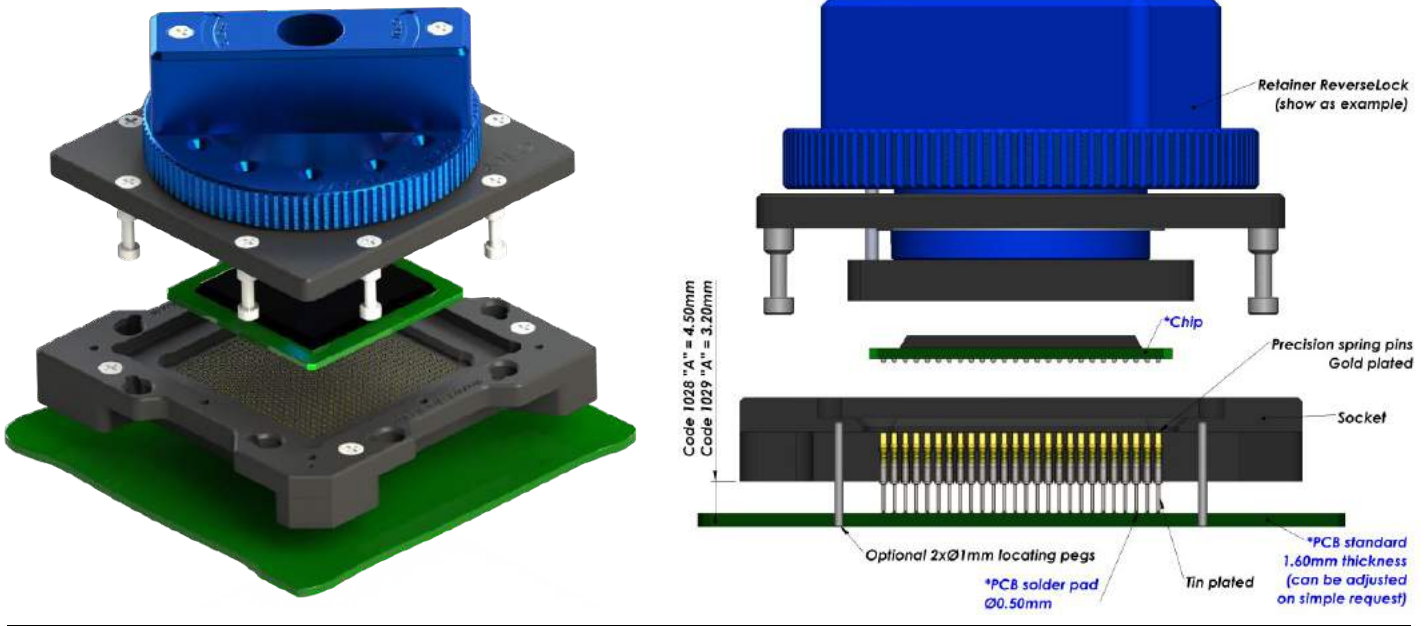

**E-tec Interconnect AG is the world leading Test socket manufacturer**

The Raised SMT socket lifts the socket above close-by components on PCB and uses the same footprint as your chip. Socket is simply placed and reflowed onto the PCB in the same way as the chip and it only requires a small amount of additional board space. Raised SMT sockets are available with all retention systems. We aim to solve your requirements. Please note, we will always request the chip data to ensure we offer a compatible socket. For Raised SMT sockets in general, E-tec Interconnect AG recommends the use of locating pegs, which can be soldered to the PCB for added mechanical strength.

Specifications contact type code 1029 & 1028			
Application	Surface mouting	Force	25 gr
Mounting	Raised SMT	Current rating	1.8 A
Bandwidth (GHz@-1dB)	na	Capacitance pF	na
Contact resistance	<100mOhm	Inductance nH	na
Chip contact tip shape	Single Point tip or Concave tip	Temperature range	-55°C to +150°C
PCB tip shape	Raised SMT	Mating cycles	100 K

**How to order**

**BU # #### -102# - ##### 95A #**

<p><b>Shape of tip</b></p> <p>U : Concave</p> <p><b>Options:</b></p> <p>P : Pointed</p> <p>S : Spring</p> <p>C : Crown</p>	<p><b>Nbr of contacts</b></p> <p>Depends on ballcount of chip</p>	<p><b>Contact type</b></p> <p>29 : Raised SMT – Dimension A = 3.20 mm</p> <p>28 : Special Raised SMT - Dim. A = 4.50 mm</p>	<p><b>Plating</b></p> <p>95A: Tin/Gold + Alignment plate</p> <p>Other on request</p>	<p><b>Option code</b> (see page 16-19)</p> <p>D : Dead bug</p> <p>M : Multi frames</p> <p>U : Multi packages</p> <p>S : Custom opening slot</p> <p>L : Locating pegs</p> <p>H : Heatsink</p> <p>F : Fan + Heatsink</p> <p>P : Thermal drain pad</p> <p>W : Transparent lid</p> <p>I : Steel retention lid</p> <p>B : Aluminium retention lid</p> <p>T : Torque tool fixture</p> <p>G : Handling button</p>
<p><b>Retention frame type (Lid)</b> (see page 12-15)</p> <p>W: TwistLock</p> <p>F : FastLock</p> <p>B : SpringLock</p> <p>H : Open Clamshell Alu (&lt;200 contacts)</p> <p>J : Clamshell Alu (&gt;200 contacts)</p> <p>L : Open Lever Clamshell Alu (&gt;200 contacts)</p>		<p>S : ScrewLock</p> <p>Q : Open QuickLock (&lt;200 contacts)</p> <p>D : QuickLock (&gt;200 contacts)</p> <p>M : Injection Molded ClamShell</p> <p>R : ReverseLock</p> <p>T : SlimLock</p>		<p><b>Grid code / Config. code</b></p> <p>Will be given by the factory after receipt of the chip datasheet</p>

# Probe Pin Solderless Compression Test Socket

For BGA / Bumped chip / WLCSP / eMMC Package

1.00 mm pitch (from 1.00 mm to 1.26 mm)

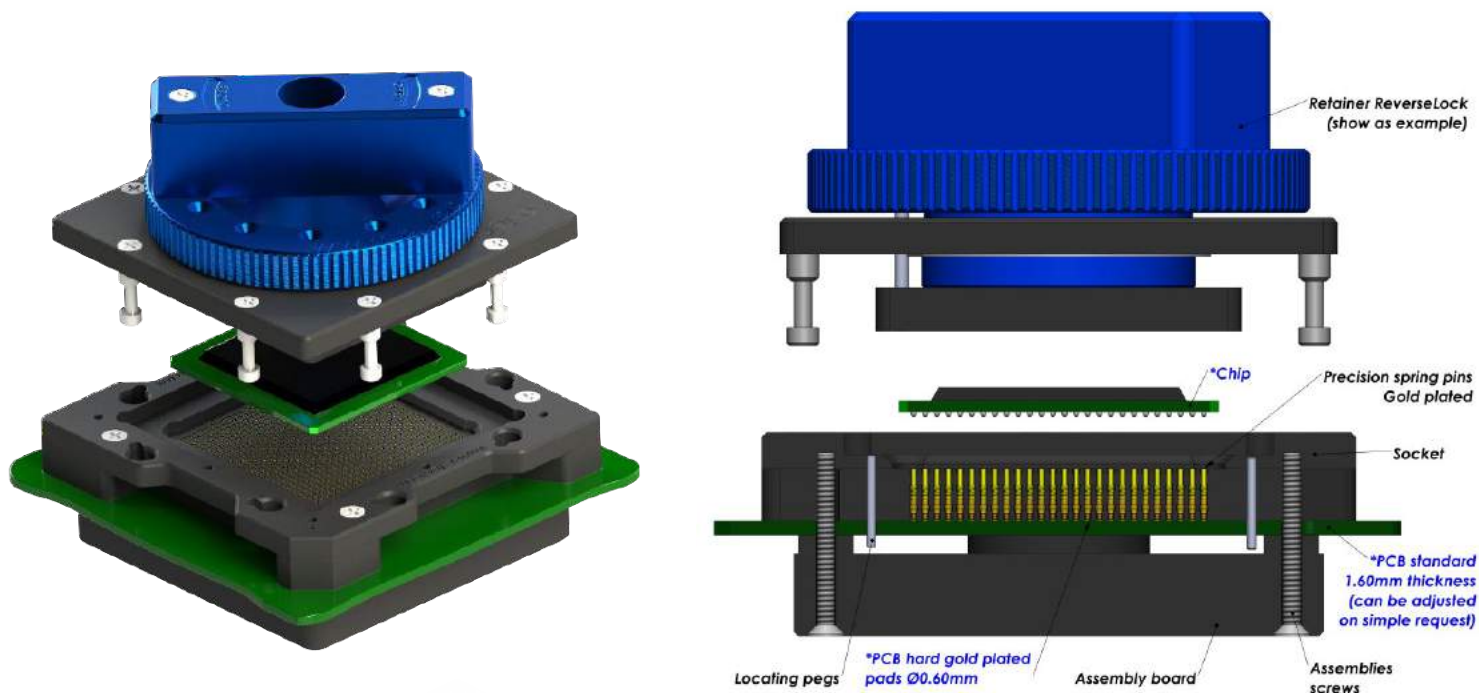
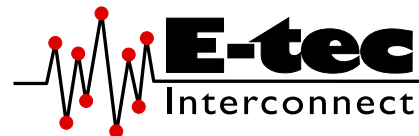

***E-tec Interconnect AG is the world leading Test socket manufacturer***

Probe Pin (Pogo) Solderless compression Test Sockets type are available for any chip size and pitch and are attached with 2, 4 or 8 screws to the PCB. The assembly board ensures perfect coplanarity of the socket. Contact reliability is guaranteed with spring loaded gold plated contacts, which are pressed onto gold plated PCB pads. Probe Pin (Pogo) Solderless compression type sockets are available with all retention systems. We aim to solve your requirements. Please note, we will always request the chip data to ensure we offer a compatible socket.

Contacts Specifications						
Contact type code	1090	1091	1092	1093	1094	1098
Application	Standard	Long Live	High Frequency	High Power	Frequency	Frequency
Mounting	Solderless	Solderless	Solderless	Solderless	Solderless	Solderless
Bandwidth (GHz@-1dB)	3 GHz	11 GHz	31 GHz	10 GHz	9.4 GHz	30.3 GHz
Contact resistance	<100 mOhm	45 mOhm	100 mOhm	30 mOhm	25 mOhm	25 mOhm
Chip contact tip shape	Single Point tip Concave tip	Crown tip	Single Point tip	Round tip	Single Point tip	Single Point tip
PCB tip shape	Single Point tip	Single Point tip	Single Point tip	Single Point tip	Spring	Spring
Force	25 gr	35 gr	33 gr	30 gr	25 gr	25 gr
Current rating	1.8 A	3 A	1 A	4 A	5 A	2.6 A
Capacitance pF	<1 pF	0.55 pF	0.39 pF	0.19 pF	0.85 pF	0.54 pF
Inductance nH	<2 nH	0.76 nH	1.01 nH	0.93 nH	1.36 nH	1.70 nH
Impedance Ohms	45 Ω	36 Ω	46 Ω	38 Ω	35 Ω	59.9 Ω
Temperature range	-55°C to +150°C	-40°C to +120°C	-50°C to +120°C	-55°C to +180°C	-55°C to +150°C	-55°C to +150°C
Mating cycles	100 K	300 K	100 K	125 K	100 K	100 K

**More on the next page**



# Probe Pin Solderless Compression Test Socket

For BGA / Bumped chip / WLCSP / eMMC Package

1.00 mm pitch (from 1.00 mm to 1.26 mm)

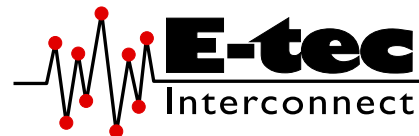

## Standard assembly boards

Small Chip size



Medium Chip size

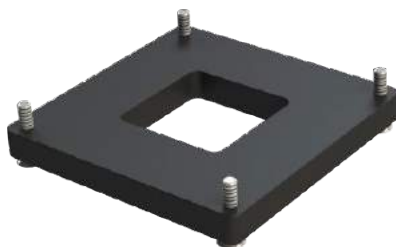

Large Chip size

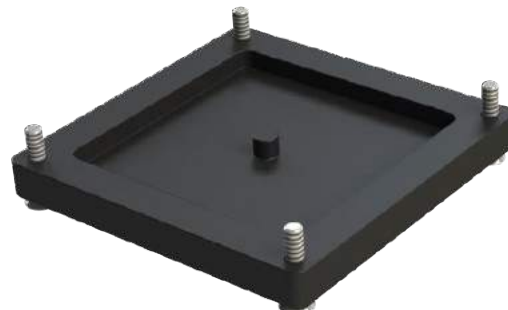

## Custom assembly boards

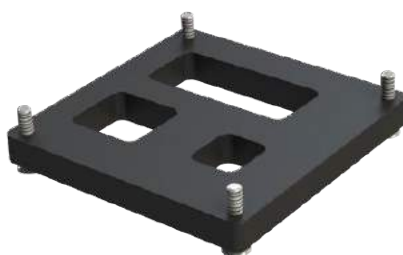
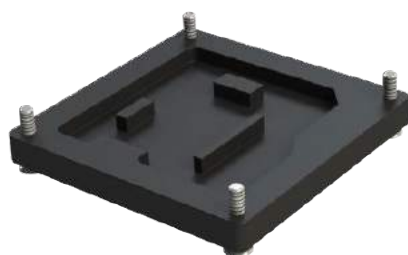

## How to order

**BU # # # # # -109# - # # # # # # 55L #**

<p><b>Shape of tip</b></p> <p>U : Concave</p> <p><b>Options:</b></p> <p>P : Pointed</p> <p>S : Spring</p> <p>C : Crown</p>	<p><b>Nbr of contacts</b></p> <p>Depends on ballcount of chip</p>	<p><b>Contact type</b></p> <p>91 to 98 : See "Contacts specification" chart</p> <p>90 : Standard solderless compression style</p> <p>9M: Special mixed contact style</p>	<p><b>Plating</b></p> <p>55L: Gold + Locating pegs</p> <p>Other on request</p>	<p><b>Option code</b> (see page 16-19)</p> <p>D : Dead bug</p> <p>M : Multi frames</p> <p>U : Multi packages</p> <p>S : Custom opening slot</p> <p>H : Heatsink</p> <p>F : Fan + Heatsink</p> <p>P : Thermal drain pad</p> <p>W: Transparent lid</p> <p>I : Steel retention lid</p> <p>B : Aluminium retention lid</p> <p>T : Torque tool fixture</p> <p>G : Handling button</p>
<p><b>Retention frame type (Lid)</b> (see page 12-15)</p> <p>W: TwistLock</p> <p>F : FastLock</p> <p>B : SpringLock</p> <p>H : Open Clamshell Alu (&lt;200 contacts)</p> <p>J : Clamshell Alu (&gt;200 contacts)</p> <p>L : Open Lever Clamshell Alu (&gt;200 contacts)</p> <p>S : ScrewLock</p> <p>Q : Open QuickLock (&lt;200 contacts)</p> <p>D : QuickLock (&gt;200 contacts)</p> <p>M : Injection Molded ClamShell</p> <p>R : ReverseLock</p> <p>T : SlimLock</p>		<p><b>Grid code / Config. code</b></p> <p>Will be given by the factory after receipt of the chip datasheet</p>		



# Elastomer Solderless Compression Test Socket

For BGA / Bumped chip / WLCSP / eMMC Package

1.00 mm pitch (from 1.00 mm to 1.26 mm)

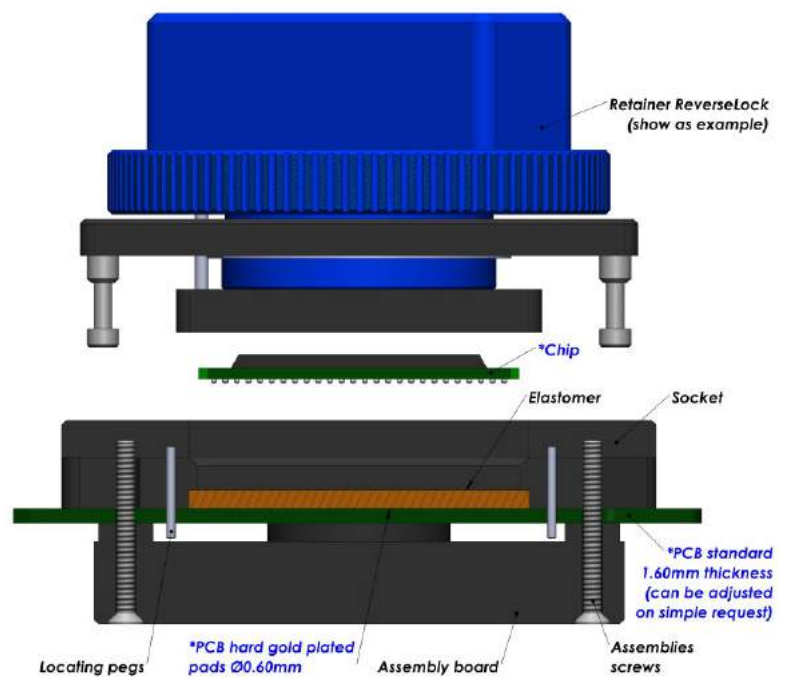

## E-tec Interconnect AG is the world leading Test socket manufacturer

The Elastomer Solderless compression Test Sockets are ideal technical solution for good signal integrity with low signal loss. The sockets are available for any chip size and pitch and are attached with 2, 4 or 8 screws to the PCB. The socket outline will be kept to a minimum and special clearances can be offered to avoid components on the PCB.

SMT and thru-hole adapter sockets are available in certain pitches (contact factory for availability first) with these elastomer interposers to allow using this high frequency interposer on PCB's which have already been laid out for SMT or thru-hole sockets. We aim to solve your requirements. Please note, we will always request the chip data to ensure we offer a compatible socket.

Contacts Specifications			
Contact type code	E1	E2	E3
Application	High Frequency		
Mounting	Solderless	Solderless	Solderless
Bandwidth (GHz@-1dB)	20 GHz	38 GHz	30 GHz
Contact resistance	30 mOhm		
Chip contact tip shape	Gold Wire		
PCB tip shape	Gold Wire		
Force	20 gr to 50 gr		
Current rating	3 A		
Capacitance pF	0.26 pF	0.12 pF	0.10 pF
Inductance nH	0.52 nH	0.35 nH	0.18 nH
Impedance Ohms	44.8 Ω	44.4 Ω	42.1 Ω
Temperature range	-40°C to +125°C		
Mating cycles	1 K		

More on the next page



# Elastomer Solderless Compression Test Socket

For BGA / Bumped chip / WLCSP / eMMC Package

1.00 mm pitch (from 1.00 mm to 1.26 mm)

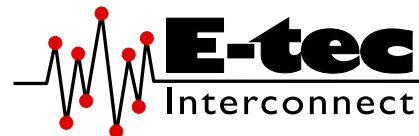

## Standard assembly boards

Small Chip size



Medium Chip size

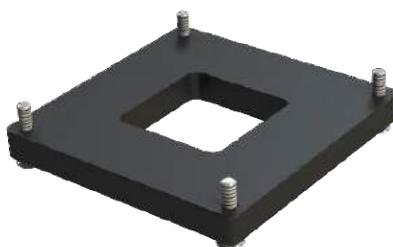

Large Chip size

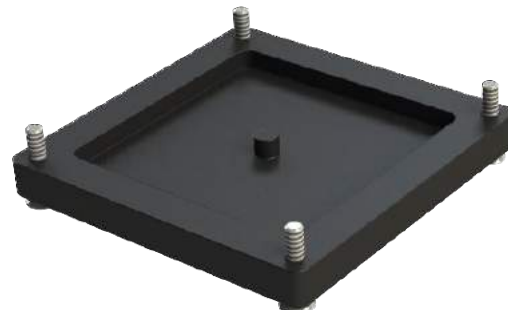

## Custom assembly boards

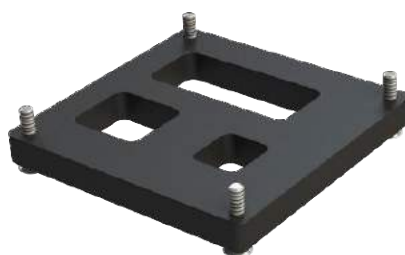
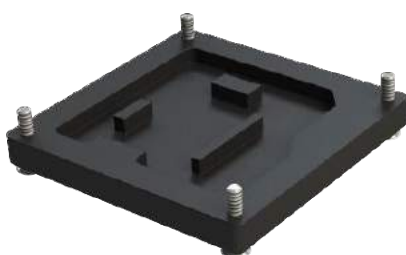

## How to order

**BE# #### -10E# - ##### 55L #**

<p><b>Shape of tip</b></p> <p>E : Elastomer</p>	<p><b>Nbr of contacts</b></p> <p>Depends on ballcount of chip</p>	<p><b>Contact type</b></p> <p>E1 : High Frequency 20 GHz E2 : High Frequency 38 GHz E3 : High Frequency 30 GHz</p>	<p><b>Plating</b></p> <p>55L: Gold + Locating pegs</p>	<p><b>Option code</b> (see page 16-19)</p> <p>M : Multi frames U : Multi packages S : Custom opening slot H : Heatsink F : Fan + Heatsink W : Transparent lid I : Steel retention lid B : Aluminium retention lid G : Handling button</p>
<p><b>Retention frame type (Lid)</b> (see page 12-15)</p> <p>W : TwistLock F : FastLock B : SpringLock H : Open Clamshell Alu (&lt;200 contacts) J : Clamshell Alu (&gt;200 contacts) L : Open Lever Clamshell Alu (&gt;200 contacts)</p> <p>S : ScrewLock Q : Open QuickLock (&lt;200 contacts) D : QuickLock (&gt;200 contacts) M : Injection Molded ClamShell R : ReverseLock T : SlimLock</p>		<p><b>Grid code / Config. code</b></p> <p>Will be given by the factory after receipt of the chip datasheet</p>		







# Through-hole (THT) soldering Test Socket

For BGA / Bumped chip / WLCSP / eMMC Package

1.27 mm pitch (from 1.27 mm upwards)

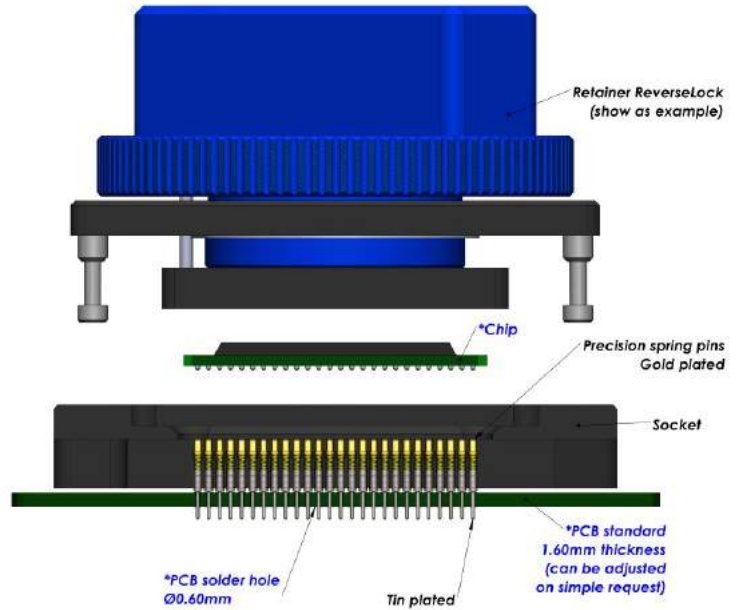
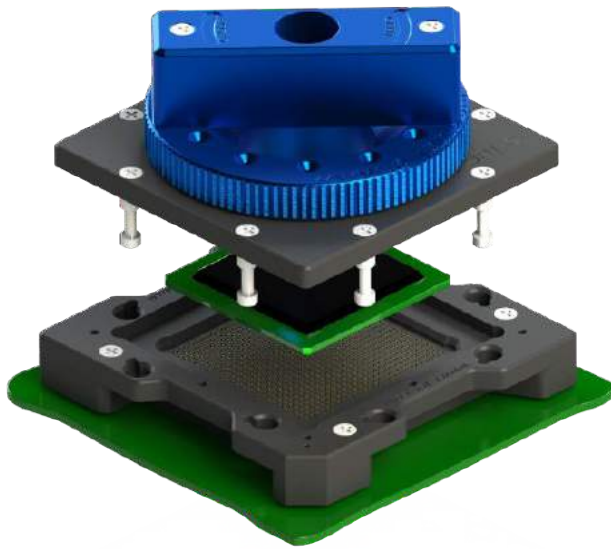
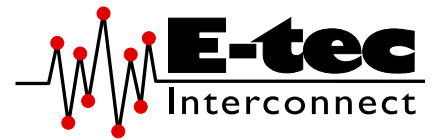

**E-tec Interconnect AG is the world leading Test socket manufacturer**

The Through-hole socket uses the same footprint as your chip. Socket is simply placed and wave soldered onto the PCB in the same way as the chip and it only requires a small amount of additional board space. Through-hole sockets are available with all retention systems. Please note, we will always request the chip data to ensure we offer a compatible socket.

Specifications contact type code 1270			
Application	Through-hole technology	Force	25 gr
Mounting	THT	Current rating	2.2 A
Bandwidth (GHz@-1dB)	3 GHz	Capacitance pF	< 1 pF
Contact resistance	<100mOhm	Inductance nH	< 2 nH
Chip contact tip shape	Single Point tip or Concave tip	Temperature range	-55°C to +150°C
PCB tip shape	Through-hole	Mating cycles	100 K

## How to order

**BU # #### -127# - ##### #5 #**

<p><b>Shape of tip</b></p> <p>U : Concave</p> <p><b>Options:</b></p> <p>P : Pointed</p> <p>S : Spring</p> <p>C : Crown</p>	<p><b>Nbr of contacts</b></p> <p>Depends on ballcount of chip</p>	<p><b>Contact type</b></p> <p>70 : Standard THT</p> <p>72 : Special THT to plug into MGS adapters</p>	<p><b>Plating</b></p> <p>95: Tin / Gold</p> <p>55: Gold / Gold</p> <p>Other on request</p>	<p><b>Option code</b> (see page 16-19)</p> <p>D : Dead bug</p> <p>M : Multi frames</p> <p>U : Multi packages</p> <p>S : Custom opening slot</p> <p>L : Locating pegs</p> <p>A : Alignment plate</p> <p>H : Heatsink</p> <p>F : Fan + Heatsink</p> <p>P : Thermal drain pad</p> <p>W : Transparent lid</p> <p>I : Steel retention lid</p> <p>B : Aluminium retention lid</p> <p>T : Torque tool fixture</p> <p>G : Handling button</p>
<p><b>Retention frame type (Lid)</b> (see page 12-15)</p> <p>W : TwistLock</p> <p>F : FastLock</p> <p>B : SpringLock</p> <p>H : Open Clamshell Alu (&lt;200 contacts)</p> <p>J : Clamshell Alu (&gt;200 contacts)</p> <p>L : Open Lever Clamshell Alu (&gt;200 contacts)</p>		<p>S : ScrewLock</p> <p>Q : Open QuickLock (&lt;200 contacts)</p> <p>D : QuickLock (&gt;200 contacts)</p> <p>M : Injection Molded ClamShell</p> <p>R : ReverseLock</p> <p>T : SlimLock</p>		<p><b>Grid code / Config. code</b></p> <p>Will be given by the factory after receipt of the chip datasheet</p>



**Standard SMT soldering Test Socket**  
 For BGA / Bumped chip / WLCSP / eMMC Package  
**1.27 mm pitch** (from 1.27 mm upwards)

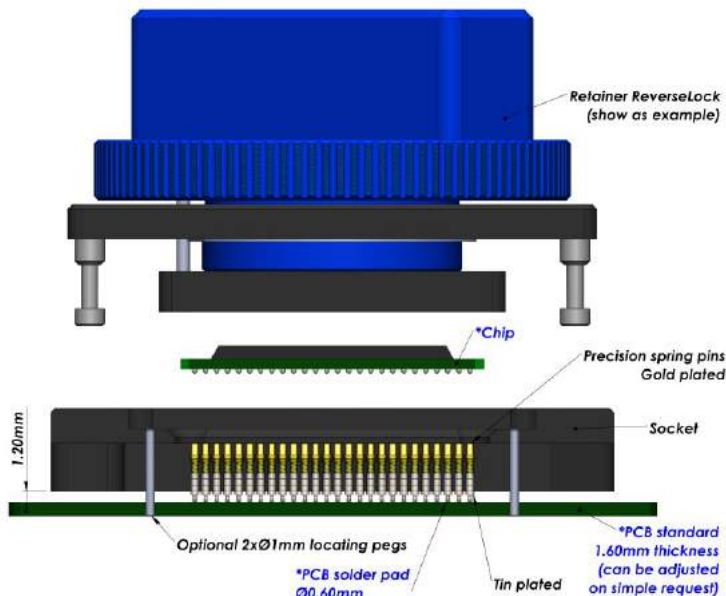
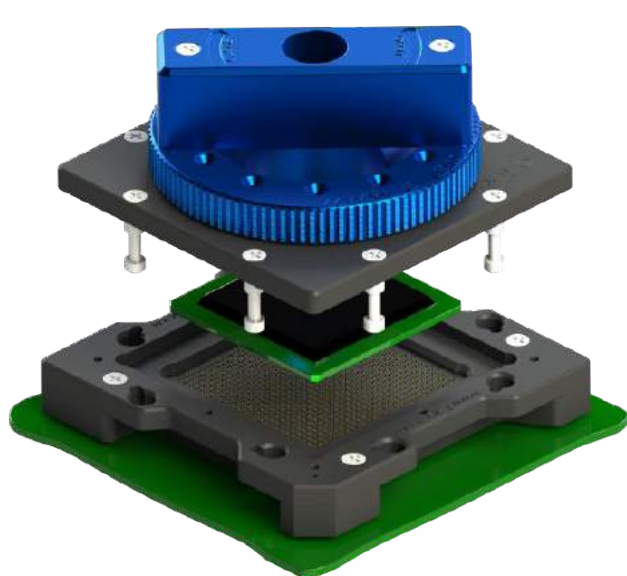
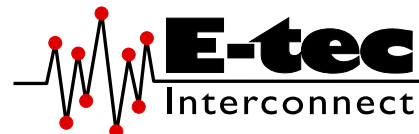

**E-tec Interconnect AG is the world leading Test socket manufacturer**

The SMT socket uses the same footprint as your chip. Socket is simply placed and reflowed onto the PCB in the same way as the chip and it only requires a small amount of additional board space. SMT type sockets are available with all retention systems. We aim to solve your requirements. Please note, we will always request the chip data to ensure we offer a compatible socket. For SMT sockets in general, E-tec Interconnect AG recommends the use of locating pegs, which can be soldered to the PCB for added mechanical strength.

Specifications contact type code 1230			
<b>Application</b>	Surface mouting	<b>Force</b>	25 gr
<b>Mounting</b>	SMT	<b>Current rating</b>	2.2 A
<b>Bandwidth (GHz@-1dB)</b>	3 GHz	<b>Capacitance pF</b>	< 1 pF
<b>Contact resistance</b>	<100mOhm	<b>Inductance nH</b>	< 2 nH
<b>Chip contact tip shape</b>	Single Point tip or Concave tip	<b>Temperature range</b>	-55°C to +150°C
<b>PCB tip shape</b>	SMT	<b>Mating cycles</b>	100K

**How to order**

**BU # #### -1230 - ##### 95 #**

<p><b>Shape of tip</b></p> <p>U : Concave</p> <p><b>Options:</b></p> <p>P : Pointed</p> <p>S : Spring</p> <p>C : Crown</p>	<p><b>Nbr of contacts</b></p> <p>Depends on ballcount of chip</p>	<p><b>Contact type</b></p> <p>30 : Standard SMT – Dimension A = 1.20 mm</p>	<p><b>Plating</b></p> <p>95 : Tin / Gold</p> <p>Other on request</p>	<p><b>Option code</b> (see page 16-19)</p> <p>D : Dead bug</p> <p>M : Multi frames</p> <p>U : Multi packages</p> <p>S : Custom opening slot</p> <p>L : Locating pegs</p> <p>H : Heatsink</p> <p>F : Fan + Heatsink</p> <p>P : Thermal drain pad</p> <p>W : Transparent lid</p> <p>I : Steel retention lid</p> <p>B : Aluminium retention lid</p> <p>G : Handling button</p>
<p><b>Retention frame type (Lid)</b> (see page 12-15)</p> <p>W : TwistLock</p> <p>F : FastLock</p> <p>B : SpringLock</p> <p>H : Open Clamshell Alu (&lt;200 contacts)</p> <p>J : Clamshell Alu (&gt;200 contacts)</p> <p>L : Open Lever Clamshell Alu (&gt;200 contacts)</p>		<p>S : ScrewLock</p> <p>Q : Open QuickLock (&lt;200 contacts)</p> <p>D : QuickLock (&gt;200 contacts)</p> <p>M : Injection Molded ClamShell</p> <p>R : ReverseLock</p> <p>T : SlimLock</p>		<p><b>Grid code / Config. code</b></p> <p>Will be given by the factory after receipt of the chip datasheet</p>



**Raised SMT soldering Test Socket**  
 For BGA / Bumped chip / WLCSP / eMMC Package  
**1.27 mm pitch** (from 1.27 mm upwards)

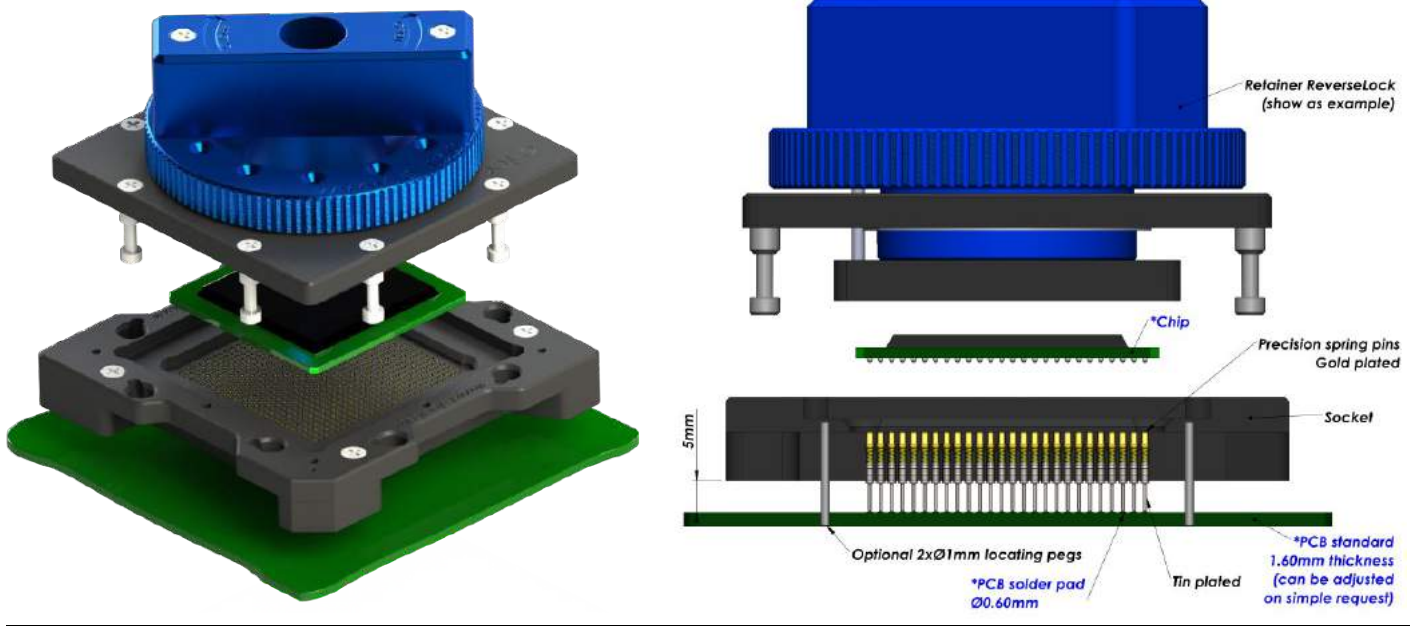
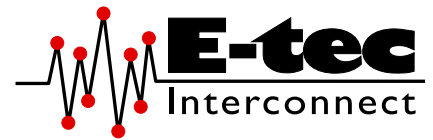

**E-tec Interconnect AG is the world leading Test socket manufacturer**

The Raised SMT socket lifts the socket above close-by components on PCB and uses the same footprint as your chip. Socket is simply placed and reflowed onto the PCB in the same way as the chip and it only requires a small amount of additional board space. Raised SMT sockets are available with all retention systems. We aim to solve your requirements. Please note, we will always request the chip data to ensure we offer a compatible socket. For Raised SMT sockets in general, E-tec Interconnect AG recommends the use of locating pegs, which can be soldered to the PCB for added mechanical strength.

Specifications contact type code 1229			
Application	Surface mouting	Force	25 gr
Mounting	Raised SMT	Current rating	2.2 A
Bandwidth (GHz@-1dB)	na	Capacitance pF	na
Contact resistance	<100mOhm	Inductance nH	na
Chip contact tip shape	Single Point tip or Concave tip	Temperature range	-55°C to +150°C
PCB tip shape	Raised SMT	Mating cycles	100 K

**How to order**

**BU # #### -1229 - ##### 95A #**

<p><b>Shape of tip</b></p> <p>U : Concave</p> <p><b>Options:</b></p> <p>P : Pointed</p> <p>S : Spring</p> <p>C : Crown</p>	<p><b>Nbr of contacts</b></p> <p>Depends on ballcount of chip</p>	<p><b>Contact type</b></p> <p>29 : Raised SMT – Dimension A = 5.00 mm</p>	<p><b>Plating</b></p> <p>95A: Tin/Gold + Alignment plate</p> <p>Other on request</p>	<p><b>Option code</b> (see page 16-19)</p> <p>D : Dead bug</p> <p>M : Multi frames</p> <p>U : Multi packages</p> <p>S : Custom opening slot</p> <p>L : Locating pegs</p> <p>H : Heatsink</p> <p>F : Fan + Heatsink</p> <p>P : Thermal drain pad</p> <p>W : Transparent lid</p> <p>I : Steel retention lid</p> <p>B : Aluminium retention lid</p> <p>T : Torque tool fixture</p> <p>G : Handling button</p>
<p><b>Retention frame type (Lid)</b> (see page 12-15)</p> <p>W: TwistLock</p> <p>F : FastLock</p> <p>B : SpringLock</p> <p>H : Open Clamshell Alu (&lt;200 contacts)</p> <p>J : Clamshell Alu (&gt;200 contacts)</p> <p>L : Open Lever Clamshell Alu (&gt;200 contacts)</p>		<p>S : ScrewLock</p> <p>Q : Open QuickLock (&lt;200 contacts)</p> <p>D : QuickLock (&gt;200 contacts)</p> <p>M : Injection Molded ClamShell</p> <p>R : ReverseLock</p> <p>T : SlimLock</p>		<p><b>Grid code / Config. code</b></p> <p>Will be given by the factory after receipt of the chip datasheet</p>



# Probe Pin Solderless Compression Test Socket

For BGA / Bumped chip / WLCSP / eMMC Package

1.27 mm pitch (from 1.27 mm upwards)

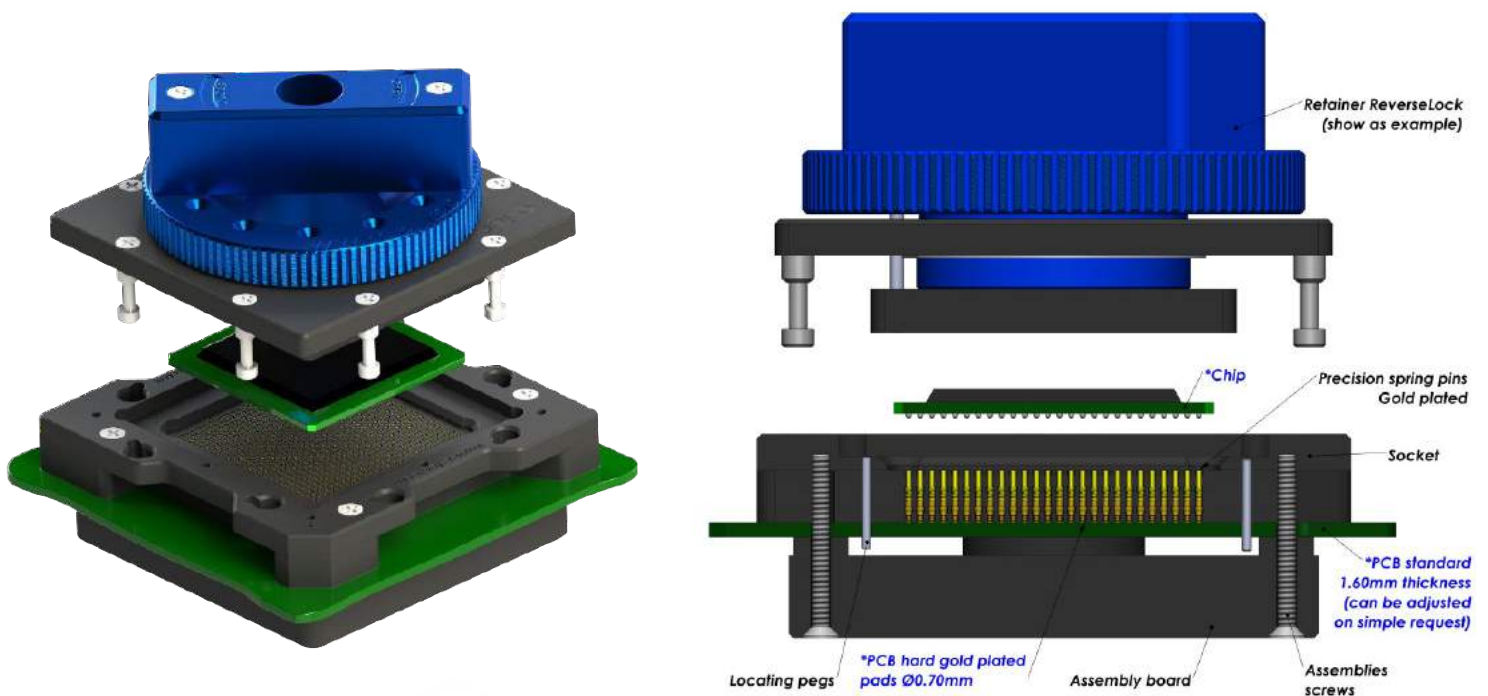

**E-tec Interconnect AG is the world leading Test socket manufacturer**

Probe Pin (Pogo) Solderless compression Test Sockets type are available for any chip size and pitch and are attached with 2, 4 or 8 screws to the PCB. The assembly board ensures perfect coplanarity of the socket. Contact reliability is guaranteed with spring loaded gold plated contacts, which are pressed onto gold plated PCB pads. Probe Pin (Pogo) Solderless compression type sockets are available with all retention systems. We aim to solve your requirements. Please note, we will always request the chip data to ensure we offer a compatible socket.

Contacts Specifications				
Contact type code	1290	1291	1294	1298
Application	Standard	High Frequency + Long Live	Frequency	Frequency
Mounting	Solderless	Solderless	Solderless	Solderless
Bandwidth (GHz@-1dB)	3 GHz	37.5 GHz	13.3 GHz	23.7 GHz
Contact resistance	<100 mOhm	45 mOhm	25 mOhm	25 mOhm
Chip contact tip shape	Single Point tip Concave tip	Crown tip	Single Point tip	Single Point tip
PCB tip shape	Single Point tip	Single Point tip	Spring	Spring
Force	25 gr	35 gr	25 gr	25 gr
Current rating	2.2 A	3 A	5 A	2.6 A
Capacitance pF	<1 pF	0.43 pF	0.76 pF	0.50 pF
Inductance nH	<2 nH	0.82 nH	1.73 nH	2.03 nH
Impedance Ohms	48 Ω	41 Ω	42.8 Ω	67.5 Ω
Temperature range	-55°C to +150°C	-40°C to +120°C	-55°C to +150°C	-55°C to +150°C
Mating cycles	100 K	300 K	100 K	100 K

More on the next page





# Probe Pin Solderless Compression Test Socket

For BGA / Bumped chip / WLCSP / eMMC Package

1.27 mm pitch (from 1.27 mm upwards)

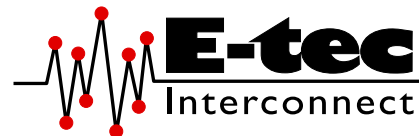

## Standard assembly boards

Small Chip size



Medium Chip size

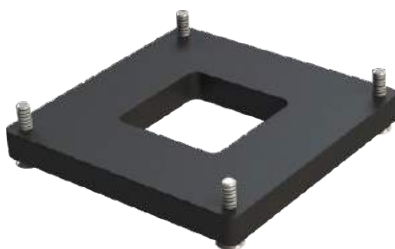

Large Chip size

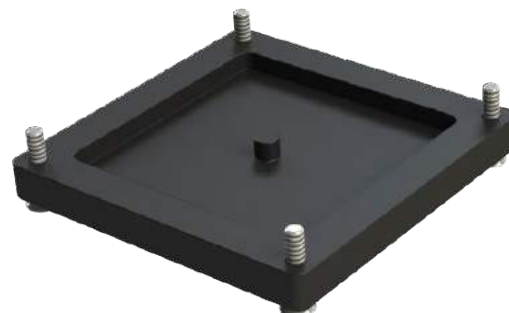

## Custom assembly boards

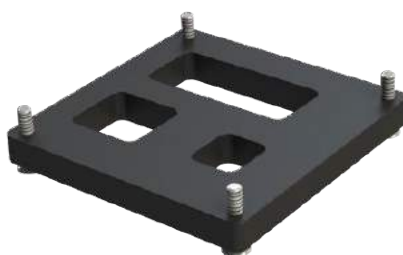
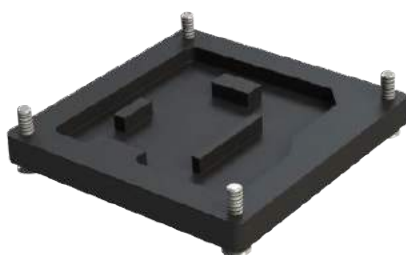

## How to order

**BU # # # # # -129# - # # # # # # 55L #**

<p><b>Shape of tip</b></p> <p>U : Concave</p> <p><b>Options:</b></p> <p>P : Pointed</p> <p>S : Spring</p> <p>C : Crown</p>	<p><b>Nbr of contacts</b></p> <p>Depends on ballcount of chip</p>	<p><b>Contact type</b></p> <p>91 to 98 : See "Contacts specification" chart</p> <p>90 : Standard solderless compression style</p> <p>9M: Special mixed contact style</p>	<p><b>Plating</b></p> <p>55L: Gold + Locating pegs</p> <p>Other on request</p>	<p><b>Option code</b> (see page 16-19)</p> <p>D : Dead bug</p> <p>M : Multi frames</p> <p>U : Multi packages</p> <p>S : Custom opening slot</p> <p>H : Heatsink</p> <p>F : Fan + Heatsink</p> <p>P : Thermal drain pad</p> <p>W : Transparent lid</p> <p>I : Steel retention lid</p> <p>B : Aluminium retention lid</p> <p>T : Torque tool fixture</p> <p>G : Handling button</p>
<p><b>Retention frame type (Lid)</b> (see page 12-15)</p> <p>W: TwistLock</p> <p>F : FastLock</p> <p>B : SpringLock</p> <p>H : Open Clamshell Alu (&lt;200 contacts)</p> <p>J : Clamshell Alu (&gt;200 contacts)</p> <p>L : Open Lever Clamshell Alu (&gt;200 contacts)</p> <p>S : ScrewLock</p> <p>Q : Open QuickLock (&lt;200 contacts)</p> <p>D : QuickLock (&gt;200 contacts)</p> <p>M : Injection Molded ClamShell</p> <p>R : ReverseLock</p> <p>T : SlimLock</p>		<p><b>Grid code / Config. code</b></p> <p>Will be given by the factory after receipt of the chip datasheet</p>		



# Elastomer Solderless Compression Test Socket

For BGA / Bumped chip / WLCSP / eMMC Package

1.27 mm pitch (from 1.00 mm upwards)

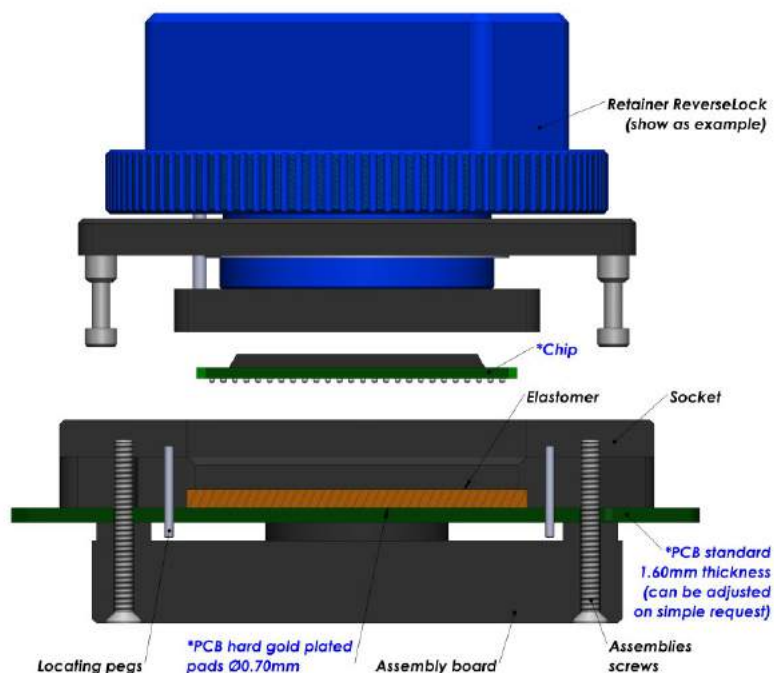
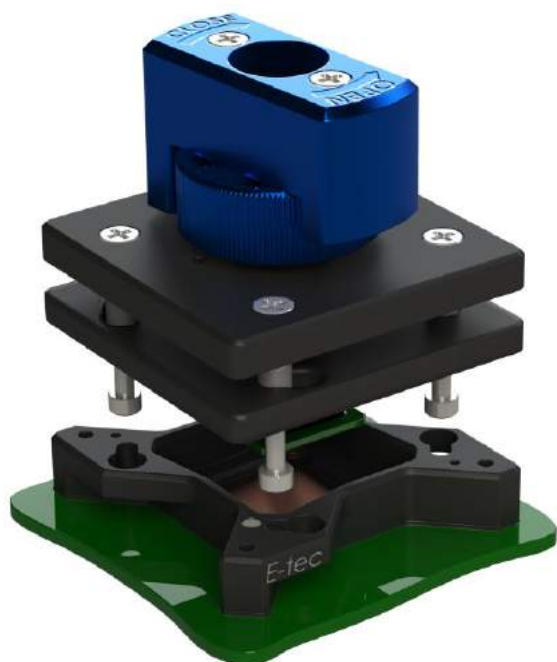
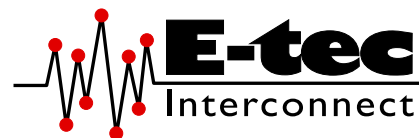

## E-tec Interconnect AG is the world leading Test socket manufacturer

The Elastomer Solderless compression Test Sockets are ideal technical solution for good signal integrity with low signal loss. The sockets are available for any chip size and pitch and are attached with 2, 4 or 8 screws to the PCB. The socket outline will be kept to a minimum and special clearances can be offered to avoid components on the PCB.

SMT and thru-hole adapter sockets are available in certain pitches (contact factory for availability first) with these elastomer interposers to allow using this high frequency interposer on PCB's which have already been laid out for SMT or thru-hole sockets. We aim to solve your requirements. Please note, we will always request the chip data to ensure we offer a compatible socket.

Contacts Specifications			
Contact type code	E1	E2	E3
Application	High Frequency		
Mounting	Solderless	Solderless	Solderless
Bandwidth (GHz@-1dB)	20 GHz	38 GHz	30 GHz
Contact resistance	30 mOhm		
Chip contact tip shape	Gold Wire		
PCB tip shape	Gold Wire		
Force	20 gr to 50 gr		
Current rating	3 A		
Capacitance pF	0.26 pF	0.12 pF	0.10 pF
Inductance nH	0.52 nH	0.35 nH	0.18 nH
Impedance Ohms	44.8 Ω	44.4 Ω	42.1 Ω
Temperature range	-40°C to +125°C		
Mating cycles	1 K		

More on the next page



# Elastomer Solderless Compression Test Socket

For BGA / Bumped chip / WLCSP / eMMC Package

1.27 mm pitch (from 1.00 mm upwards)

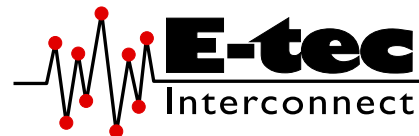

## Standard assembly boards

Small Chip size



Medium Chip size

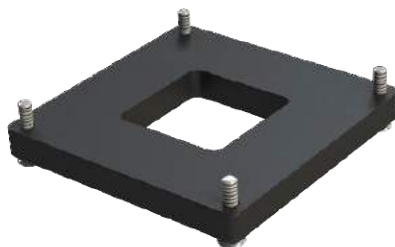

Large Chip size

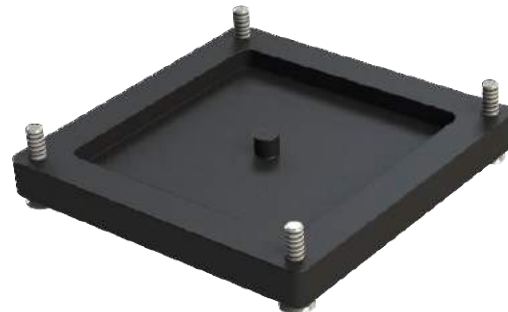

## Custom assembly boards

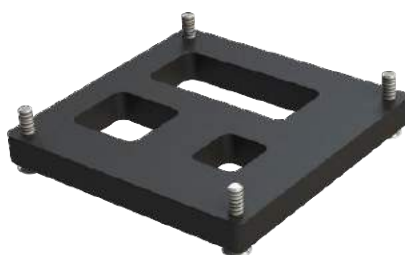
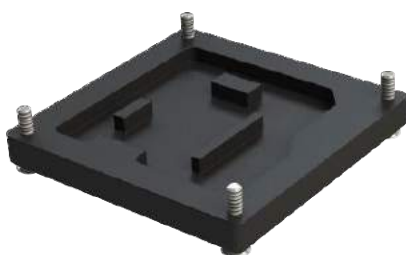

## How to order

**BE# #### -12E# - ##### 55L #**

**Shape of tip**

**E** : Elastomer

**Nbr of contacts**

Depends on ballcount of chip

**Contact type**

**E1** : High Frequency 20 GHz  
**E2** : High Frequency 38 GHz  
**E3** : High Frequency 30 GHz

**Plating**

**55L**: Gold + Locating pegs

**Option code** (see page 16-19)

**M** : Multi frames  
**U** : Multi packages  
**S** : Custom opening slot  
**H** : Heatsink  
**F** : Fan + Heatsink  
**W** : Transparent lid  
**I** : Steel retention lid  
**B** : Aluminium retention lid  
**G** : Handling button

**Retention frame type (Lid)** (see page 12-15)

**W** : TwistLock  
**F** : FastLock  
**B** : SpringLock  
**H** : Open Clamshell Alu (<200 contacts)  
**J** : Clamshell Alu (>200 contacts)  
**L** : Open Lever Clamshell Alu (>200 contacts)  
**S** : ScrewLock  
**Q** : Open QuickLock (<200 contacts)  
**D** : QuickLock (>200 contacts)  
**M** : Injection Molded ClamShell  
**R** : ReverseLock  
**T** : SlimLock

**Grid code / Config. code**

Will be given by the factory after receipt of the chip datasheet



# Probe Pin Solderless Compression Test Socket

For LGA / QFN / MLF / MLP / LCC Package

0.30 mm pitch (from 0.30 mm to 0.39 mm)

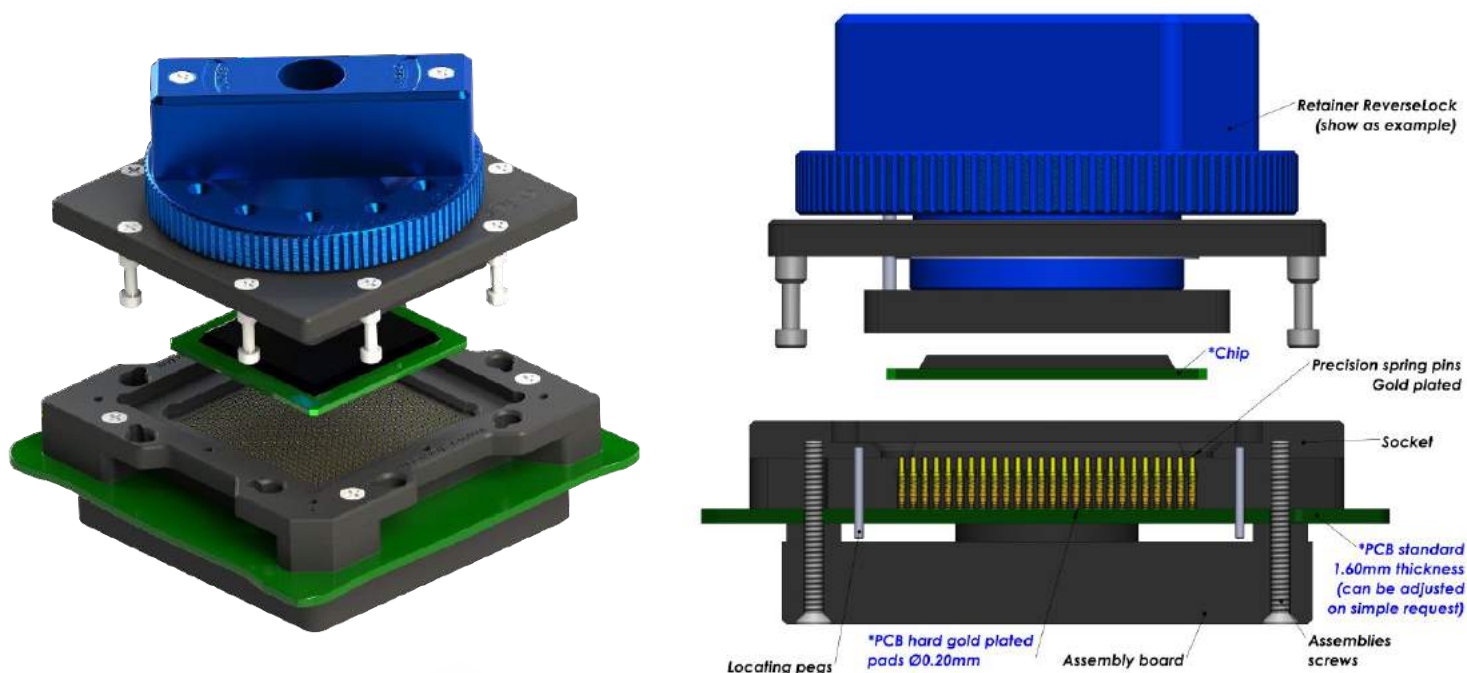
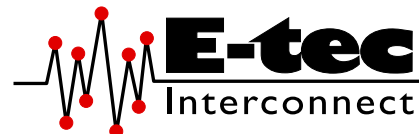

**E-tec Interconnect AG is the world leading Test socket manufacturer**

Probe Pin (Pogo) Solderless compression Test Sockets type are available for any chip size and pitch and are attached with 2, 4 or 8 screws to the PCB. The assembly board ensures perfect coplanarity of the socket. Contact reliability is guaranteed with spring loaded gold plated contacts, which are pressed onto gold plated PCB pads. Probe Pin (Pogo) Solderless compression type sockets are available with all retention systems. We aim to solve your requirements. Please note, we will always request the chip data to ensure we offer a compatible socket.

Contacts Specifications	
Contact type code	0398
Application	High Frequency
Mounting	Solderless
Bandwidth (GHz@-1dB)	19 GHz
Contact resistance	<100 mOhm
Chip contact tip shape	Single Point tip
PCB tip shape	Single Point tip
Force	17 gr
Current rating	0.8 A
Capacitance pF	0.50 pF
Inductance nH	1.27 nH
Impedance Ohms	45 Ω
Temperature range	-45°C to +125°C
Mating cycles	150 K

More on the next page



# Probe Pin Solderless Compression Test Socket

For LGA / QFN / MLF / MLP / LCC Package

0.30 mm pitch (from 0.30 mm to 0.39 mm)



## Standard assembly boards

Small Chip size



Medium Chip size

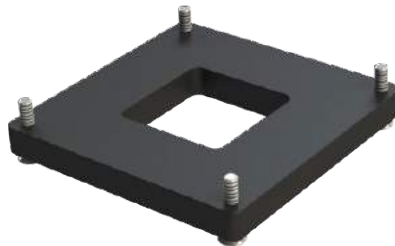

Large Chip size



## Custom assembly boards

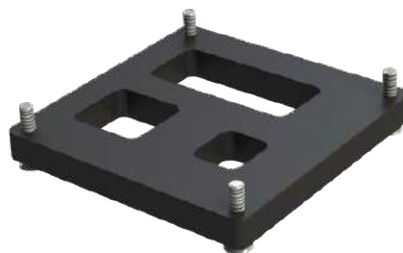
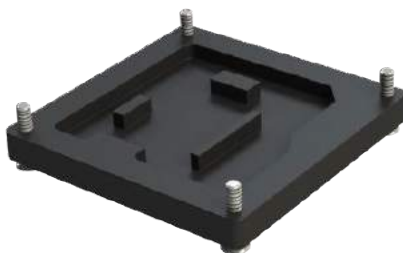

## How to order

**LP # ##### -0398 - ##### 55L #**

<p><b>Shape of tip</b></p> <p>P : Pointed</p> <p><b>Options:</b></p> <p>C : Crown</p>	<p><b>Nbr of contacts</b></p> <p>Depends on ballcount of chip</p>	<p><b>Contact type</b></p> <p>98 : See "Contacts specification" chart</p>	<p><b>Plating</b></p> <p>55L: Gold + Locating pegs</p> <p>Other on request</p>	<p><b>Option code</b> (see page 16-19)</p> <p>D : Dead bug</p> <p>M : Multi frames</p> <p>U : Multi packages</p> <p>C : Converter plate</p> <p>S : Custom opening slot</p> <p>H : Heatsink</p> <p>F : Fan + Heatsink</p> <p>P : Thermal drain pad</p> <p>W : Transparent lid</p> <p>I : Steel retention lid</p> <p>B : Aluminium retention lid</p> <p>T : Torque tool fixture</p> <p>G : Handling button</p>
<p><b>Retention frame type (Lid)</b> (see page 12-15)</p> <p>W: TwistLock</p> <p>F : FastLock</p> <p>B : SpringLock</p> <p>H : Open Clamshell Alu (&lt;200 contacts)</p> <p>J : Clamshell Alu (&gt;200 contacts)</p> <p>L : Open Lever Clamshell Alu (&gt;200 contacts)</p> <p>S : ScrewLock</p> <p>Q : Open QuickLock (&lt;200 contacts)</p> <p>D : QuickLock (&gt;200 contacts)</p> <p>M : Injection Molded ClamShell</p> <p>R : ReverseLock</p> <p>T : SlimLock</p>		<p><b>Grid code / Config. code</b></p> <p>Will be given by the factory after receipt of the chip datasheet</p>		





# Elastomer Solderless Compression Test Socket

For LGA / QFN / MLF / MLP / LCC Package

0.30 mm pitch (from 0.30 mm to 0.39 mm)

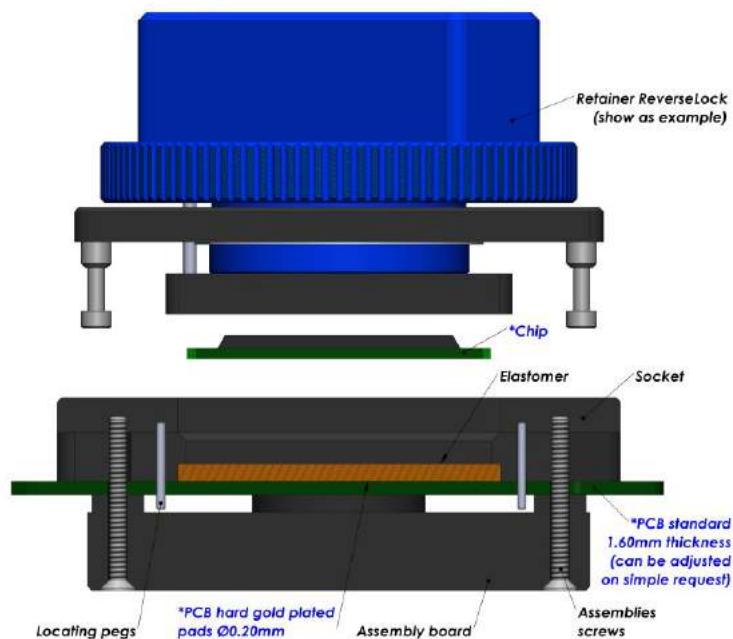
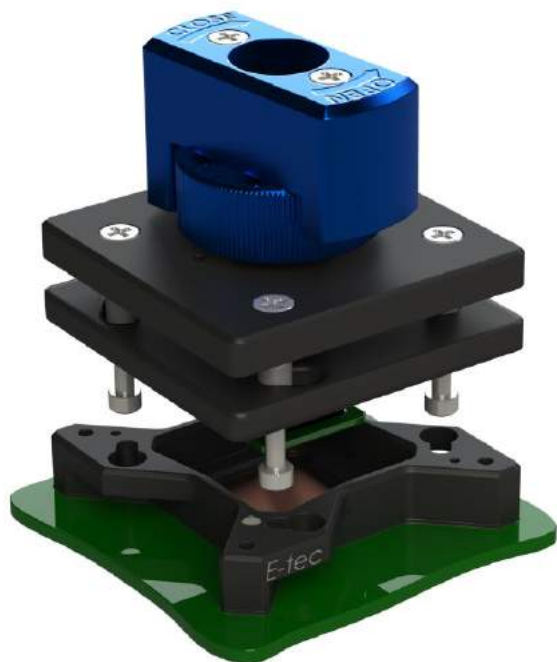
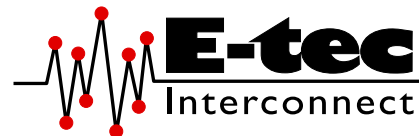

## E-tec Interconnect AG is the world leading Test socket manufacturer

The Elastomer Solderless compression Test Sockets are ideal technical solution for good signal integrity with low signal loss. The sockets are available for any chip size and pitch and are attached with 2, 4 or 8 screws to the PCB. The socket outline will be kept to a minimum and special clearances can be offered to avoid components on the PCB.

SMT and thru-hole adapter sockets are available in certain pitches (contact factory for availability first) with these elastomer interposers to allow using this high frequency interposer on PCB's which have already been laid out for SMT or thru-hole sockets. We aim to solve your requirements. Please note, we will always request the chip data to ensure we offer a compatible socket.

Contacts Specifications		
Contact type code	E2	E3
Application	High Frequency	
Mounting	Solderless	Solderless
Bandwidth (GHz@-1dB)	20.3 GHz*	18.3 GHz*
Contact resistance	30 mOhm	
Chip contact tip shape	Gold Wire	
PCB tip shape	Gold Wire	
Force	20 gr to 50 gr	
Current rating	1 A	
Capacitance pF	0.15 pF	0.14 pF
Inductance nH	0.12 nH	0.05 nH
Impedance Ohms	41 Ω	39.7 Ω
Temperature range	-40°C to +125°C	
Mating cycles	1 K	

\* Tested at 0.35mm Pitch

More on the next page



# Elastomer Solderless Compression Test Socket

For LGA / QFN / MLF / MLP / LCC Package

0.30 mm pitch (from 0.30 mm to 0.39 mm)

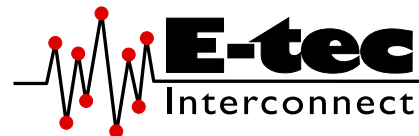

## Standard assembly boards

Small Chip size



Medium Chip size

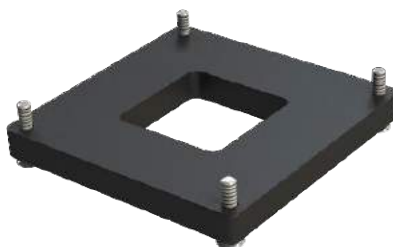

Large Chip size

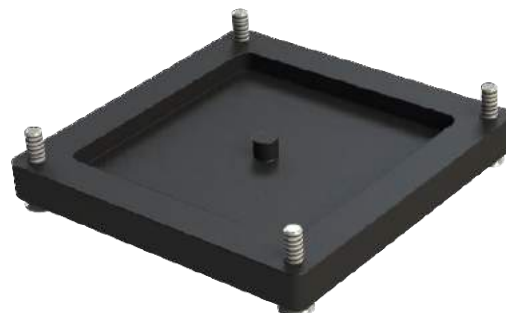

## Custom assembly boards

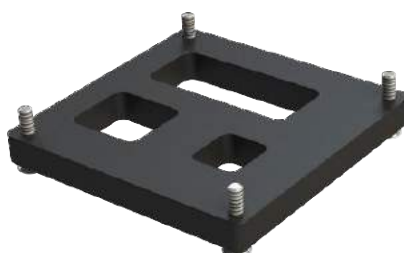
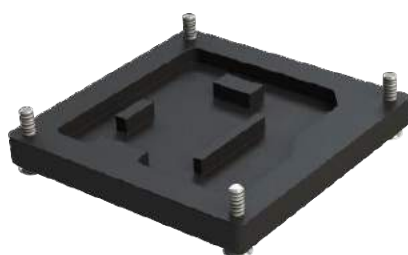

## How to order

**LE # #### -03E# - ##### 55L #**

**Shape of tip**

E : Elastomer

**Nbr of contacts**

Depends on ballcount of chip

**Contact type**

E2 : High Frequency 20.3 GHz  
E3 : High Frequency 18.3 GHz

**Plating**

55L: Gold + Locating pegs

**Option code** (see page 16-19)

M : Multi frames  
U : Multi packages  
C : Converter plate  
S : Custom opening slot  
H : Heatsink  
F : Fan + Heatsink  
W : Transparent lid  
I : Steel retention lid  
B : Aluminium retention lid  
G : Handling button

**Retention frame type (Lid)** (see page 12-15)

W : TwistLock  
F : FastLock  
B : SpringLock  
H : Open Clamshell Alu (<200 contacts)  
J : Clamshell Alu (>200 contacts)  
L : Open Lever Clamshell Alu (>200 contacts)

S : ScrewLock  
Q : Open QuickLock (<200 contacts)  
D : QuickLock (>200 contacts)  
M : Injection Molded ClamShell  
R : ReverseLock  
T : SlimLock

**Grid code / Config. code**

Will be given by the factory after receipt of the chip datasheet



# Probe Pin Solderless Compression Test Socket

For LGA / QFN / MLF / MLP / LCC Package

0.40 mm pitch (from 0.40 mm to 0.49 mm)

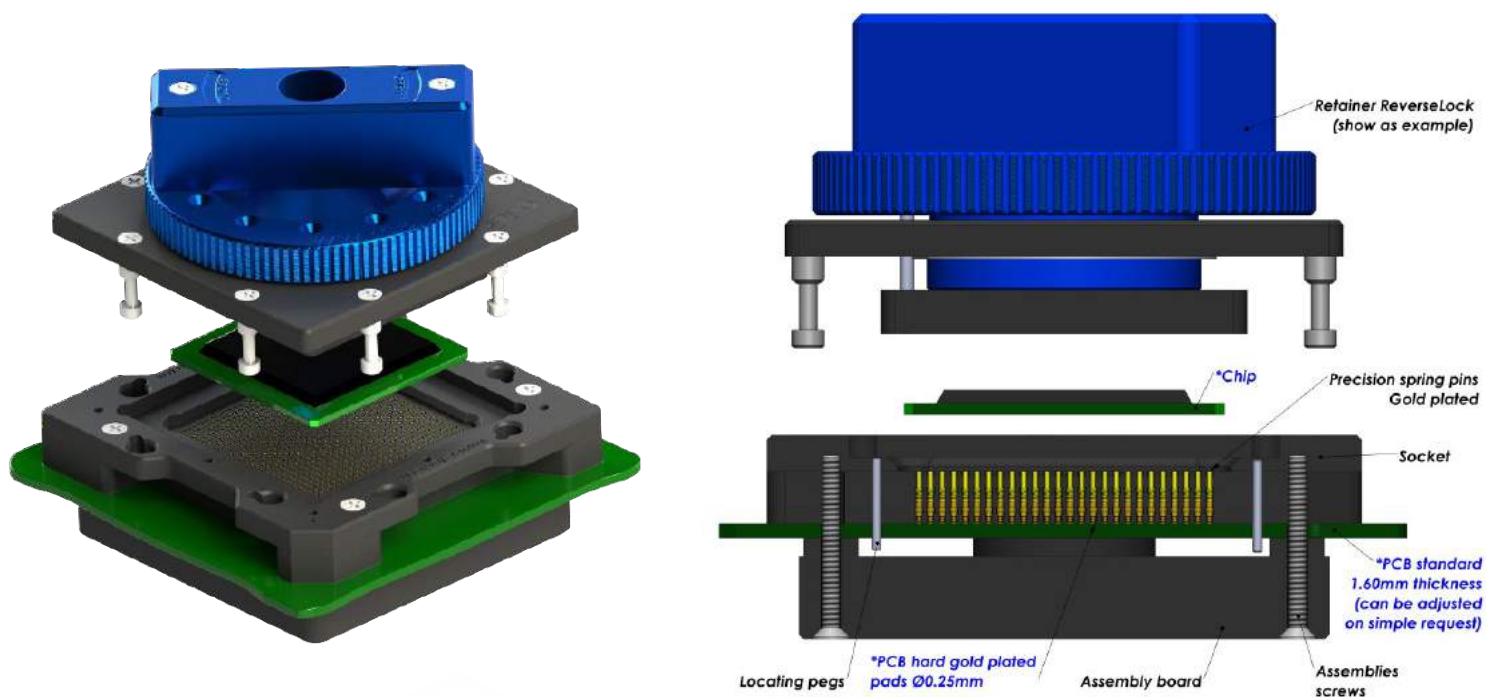
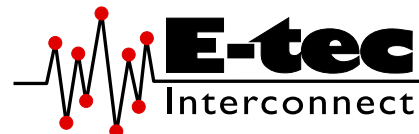

**E-tec Interconnect AG is the world leading Test socket manufacturer**

Probe Pin (Pogo) Solderless compression Test Sockets type are available for any chip size and pitch and are attached with 2, 4 or 8 screws to the PCB. The assembly board ensures perfect coplanarity of the socket. Contact reliability is guaranteed with spring loaded gold plated contacts, which are pressed onto gold plated PCB pads. Probe Pin (Pogo) Solderless compression type sockets are available with all retention systems. We aim to solve your requirements. Please note, we will always request the chip data to ensure we offer a compatible socket.

Contacts Specifications				
Contact type code	0490	0491	0492	0494
Application	Standard	Frequency	High Frequency	High Power
Mounting	Solderless	Solderless	Solderless	Solderless
Bandwidth (GHz@-1dB)	3 GHz	10 GHz	20 GHz	na
Contact resistance	<100 mOhm	100 mOhm	100 mOhm	100 mOhm
Chip contact tip shape	Single Point tip	Single Point tip	Single Point tip	Crown tip
PCB tip shape	Spring	Single Point tip	Single Point tip	Single Point tip
Force	20 gr	20 gr	20 gr	30 gr
Current rating	0.5 A	1.5 A	1.5 A	3 A
Capacitance pF	<1pF	0.90 pF	0.50 pF	na
Inductance nH	<2nH	1.50 nH	1.20 nH	na
Impedance Ohms	45 Ω	48 Ω	42 Ω	na
Temperature range	-55°C to +150°C	-40°C to +120°C	-40°C to +120°C	-40°C to +120°C
Mating cycles	100 K	300 K	100 K	100 K

More on the next page



# Probe Pin Solderless Compression Test Socket

For LGA / QFN / MLF / MLP / LCC Package

0.40 mm pitch (from 0.40 mm to 0.49 mm)

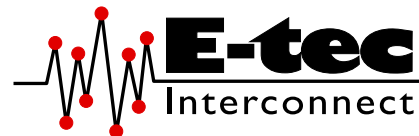

## Standard assembly boards

Small Chip size



Medium Chip size

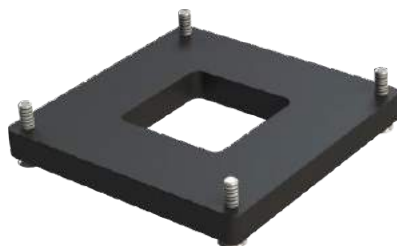

Large Chip size

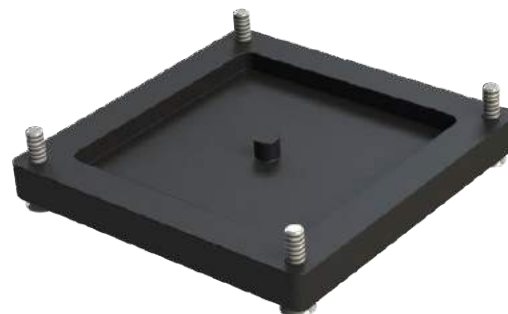

## Custom assembly boards

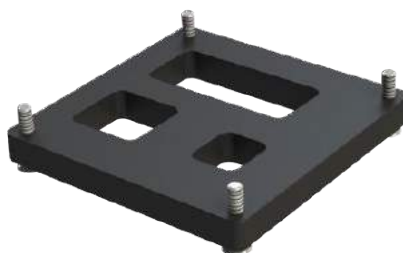
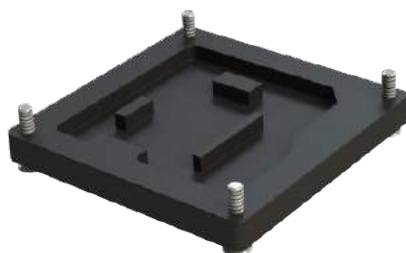

## How to order

**LP # # # # -049# - # # # # # 55L #**

<p><b>Shape of tip</b></p> <p><b>P</b> : Pointed</p> <p><b>Options:</b></p> <p><b>C</b> : Crown</p>	<p><b>Nbr of contacts</b></p> <p>Depends on ballcount of chip</p>	<p><b>Contact type</b></p> <p><b>91 to 94</b> : See "Contacts specification" chart</p> <p><b>90</b> : Standard solderless compression style</p> <p><b>9M</b> : Special mixed contact style</p>	<p><b>Plating</b></p> <p><b>55L</b>: Gold + Locating pegs</p> <p>Other on request</p>	<p><b>Option code</b> (see page 16-19)</p> <p><b>D</b> : Dead bug</p> <p><b>M</b> : Multi frames</p> <p><b>U</b> : Multi packages</p> <p><b>C</b> : Converter plate</p> <p><b>S</b> : Custom opening slot</p> <p><b>H</b> : Heatsink</p> <p><b>F</b> : Fan + Heatsink</p> <p><b>P</b> : Thermal drain pad</p> <p><b>W</b> : Transparent lid</p> <p><b>I</b> : Steel retention lid</p> <p><b>B</b> : Aluminium retention lid</p> <p><b>T</b> : Torque tool fixture</p> <p><b>G</b> : Handling button</p>
<p><b>Retention frame type (Lid)</b> (see page 12-15)</p> <p><b>W</b>: TwistLock</p> <p><b>F</b>: FastLock</p> <p><b>B</b>: SpringLock</p> <p><b>H</b>: Open Clamshell Alu (&lt;200 contacts)</p> <p><b>J</b>: Clamshell Alu (&gt;200 contacts)</p> <p><b>L</b>: Open Lever Clamshell Alu (&gt;200 contacts)</p> <p><b>S</b>: ScrewLock</p> <p><b>Q</b>: Open QuickLock (&lt;200 contacts)</p> <p><b>D</b>: QuickLock (&gt;200 contacts)</p> <p><b>M</b>: Injection Molded ClamShell</p> <p><b>R</b>: ReverseLock</p> <p><b>T</b>: SlimLock</p>		<p><b>Grid code / Config. code</b></p> <p>Will be given by the factory after receipt of the chip datasheet</p>		



# Elastomer Solderless Compression Test Socket

For LGA / QFN / MLF / MLP / LCC Package

0.40 mm pitch (from 0.40 mm to 0.49 mm)

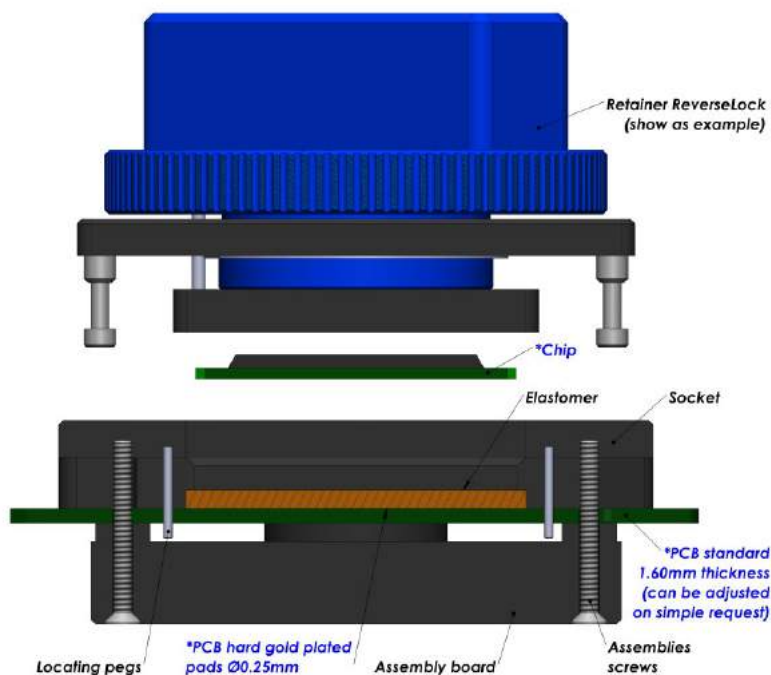
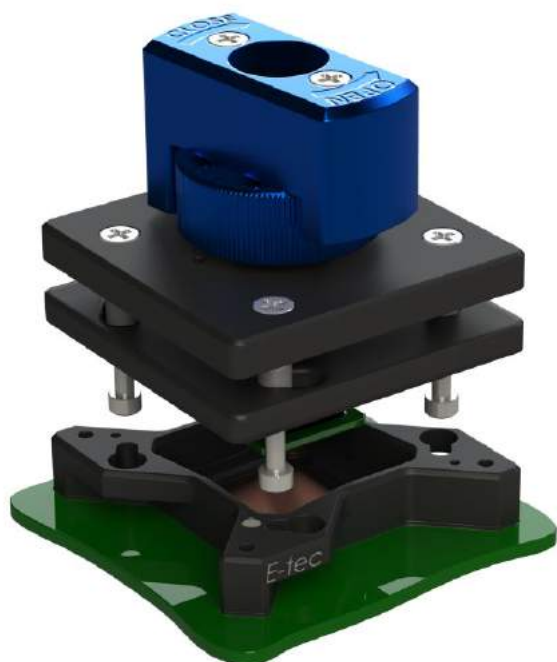
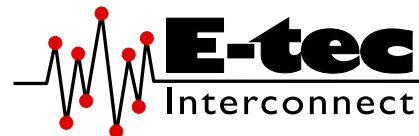

## ***E-tec Interconnect AG is the world leading Test socket manufacturer***

The Elastomer Solderless compression Test Sockets are ideal technical solution for good signal integrity with low signal loss. The sockets are available for any chip size and pitch and are attached with 2, 4 or 8 screws to the PCB. The socket outline will be kept to a minimum and special clearances can be offered to avoid components on the PCB.

SMT and thru-hole adapter sockets are available in certain pitches (contact factory for availability first) with these elastomer interposers to allow using this high frequency interposer on PCB's which have already been laid out for SMT or thru-hole sockets. We aim to solve your requirements. Please note, we will always request the chip data to ensure we offer a compatible socket.

Contacts Specifications			
Contact type code	E1	E2	E3
Application	High Frequency		
Mounting	Solderless	Solderless	Solderless
Bandwidth (GHz@-1dB)	8.4 GHz	16.5 GHz	21.3 GHz
Contact resistance	30 mOhm		
Chip contact tip shape	Gold Wire		
PCB tip shape	Gold Wire		
Force	20 gr to 50 gr		
Current rating	2.5 A		
Capacitance pF	0.28 pF	0.13 pF	0.10 pF
Inductance nH	0.26 nH	0.07 nH	0.06 nH
Impedance Ohms	34.7 Ω	38.9 Ω	42.1 Ω
Temperature range	-40°C to +125°C		
Mating cycles	1 K		

More on the next page





# Elastomer Solderless Compression Test Socket

For LGA / QFN / MLF / MLP / LCC Package

0.40 mm pitch (from 0.40 mm to 0.49 mm)

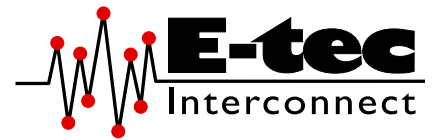

## Standard assembly boards

Small Chip size



Medium Chip size

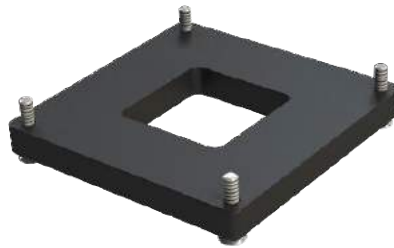

Large Chip size

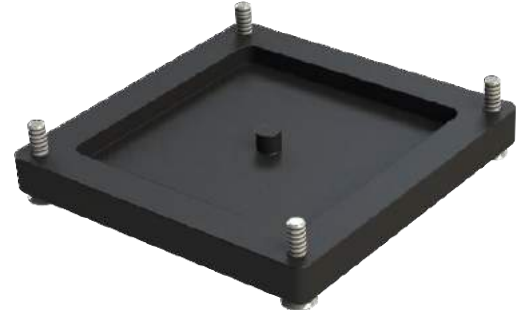

## Custom assembly boards

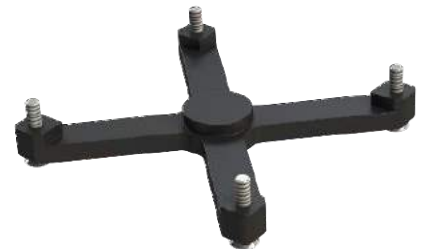
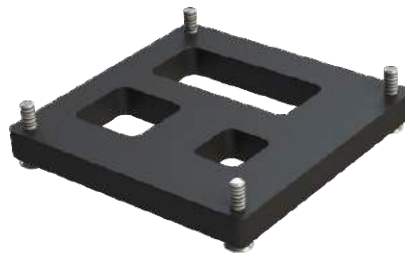
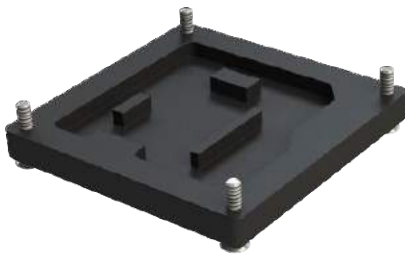

## How to order

**LE # #### -04E# - ##### 55L #**

**Shape of tip**  
E : Elastomer

**Nbr of contacts**  
Depends on ballcount of chip

**Contact type**  
E1 : High Frequency 8.4 GHz  
E2 : High Frequency 16.5 GHz  
E3: High Frequency 21.3 GHz

**Plating**  
55L: Gold + Locating pegs

**Option code** (see page 16-19)

- M : Multi frames
- U : Multi packages
- C : Converter plate
- S : Custom opening slot
- H : Heatsink
- F : Fan + Heatsink
- W : Transparent lid
- I : Steel retention lid
- B : Aluminium retention lid
- G : Handling button

**Retention frame type (Lid)** (see page 12-15)

- |  |                                    |
|--|------------------------------------|
| W : TwistLock                                | S : ScrewLock                      |
| F : FastLock                                 | Q : Open QuickLock (<200 contacts) |
| B : SpringLock                               | D : QuickLock (>200 contacts)      |
| H : Open Clamshell Alu (<200 contacts)       | M : Injection Molded ClamShell     |
| J : Clamshell Alu (>200 contacts)            | R : ReverseLock                    |
| L : Open Lever Clamshell Alu (>200 contacts) | T : SlimLock                       |

**Grid code / Config. code**  
Will be given by the factory after receipt of the chip datasheet





# Through-hole (THT) soldering Test Socket

For LGA / QFN / MLF / MLP / LCC Package

0.50 mm pitch (from 0.50 mm up to 0.79 mm)

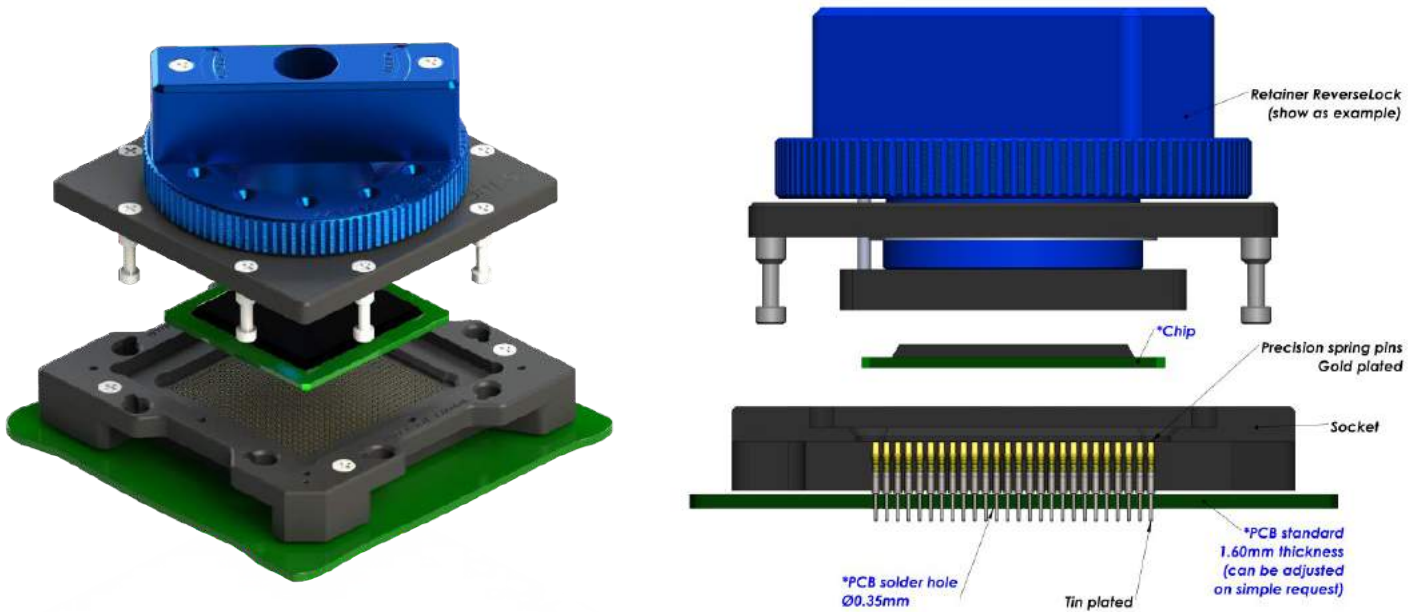
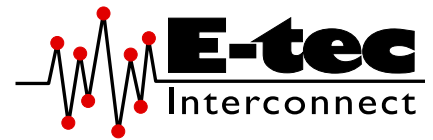

**E-tec Interconnect AG is the world leading Test socket manufacturer**

The Through-hole socket uses the same footprint as your chip. Socket is simply placed and wave soldered onto the PCB in the same way as the chip and it only requires a small amount of additional board space. Through-hole sockets are available with all retention systems. Please note, we will always request the chip data to ensure we offer a compatible socket.

Specifications contact type code 0570			
Application	Through-hole technology	Force	30 gr
Mounting	THT	Current rating	1 A
Bandwidth (GHz@-1dB)	2.7 GHz	Capacitance pF	< 1 pF
Contact resistance	<100mOhm	Inductance nH	< 2 nH
Chip contact tip shape	Single Point tip or Concave tip	Temperature range	-55°C to +150°C
PCB tip shape	Through-hole	Mating cycles	100 K

## How to order

**LP # #### -0570 - ##### 95 #**

<p><b>Shape of tip</b></p> <p>P : Pointed</p> <p><b>Options:</b></p> <p>C : Crown</p>	<p><b>Nbr of contacts</b></p> <p>Depends on ballcount of chip</p>	<p><b>Contact type</b></p> <p>70 : Standard THT</p>	<p><b>Plating</b></p> <p>95: Tin / Gold</p> <p>Other on request</p>	<p><b>Option code</b> (see page 16-19)</p> <p>D : Dead bug</p> <p>M : Multi frames</p> <p>U : Multi packages</p> <p>C : Converter plate</p> <p>S : Custom opening slot</p> <p>L : Locating pegs</p> <p>A : Alignment plate</p> <p>H : Heatsink</p> <p>F : Fan + Heatsink</p> <p>P : Thermal drain pad</p> <p>W : Transparent lid</p> <p>I : Steel retention lid</p> <p>B : Aluminium retention lid</p> <p>T : Torque tool fixture</p> <p>G : Handling button</p>
<p><b>Retention frame type (Lid)</b> (see page 12-15)</p> <p>W: TwistLock</p> <p>F : FastLock</p> <p>B : SpringLock</p> <p>H : Open Clamshell Alu (&lt;200 contacts)</p> <p>J : Clamshell Alu (&gt;200 contacts)</p> <p>L : Open Lever Clamshell Alu (&gt;200 contacts)</p>		<p>S : ScrewLock</p> <p>Q : Open QuickLock (&lt;200 contacts)</p> <p>D : QuickLock (&gt;200 contacts)</p> <p>M : Injection Molded ClamShell</p> <p>R : ReverseLock</p> <p>T : SlimLock</p>		<p><b>Grid code / Config. code</b></p> <p>Will be given by the factory after receipt of the chip datasheet</p>



# Standard SMT soldering Test Socket

For LGA / QFN / MLF / MLP / LCC Package

0.50 mm pitch (from 0.50 mm up to 0.79 mm)

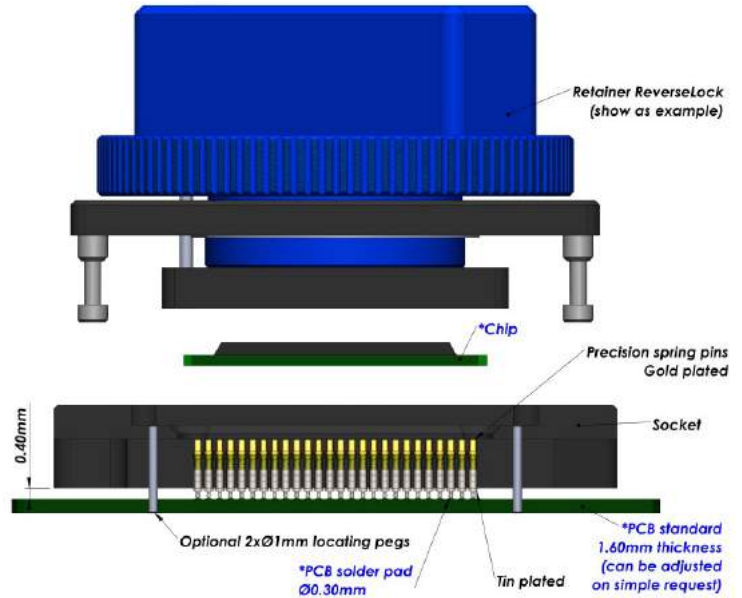
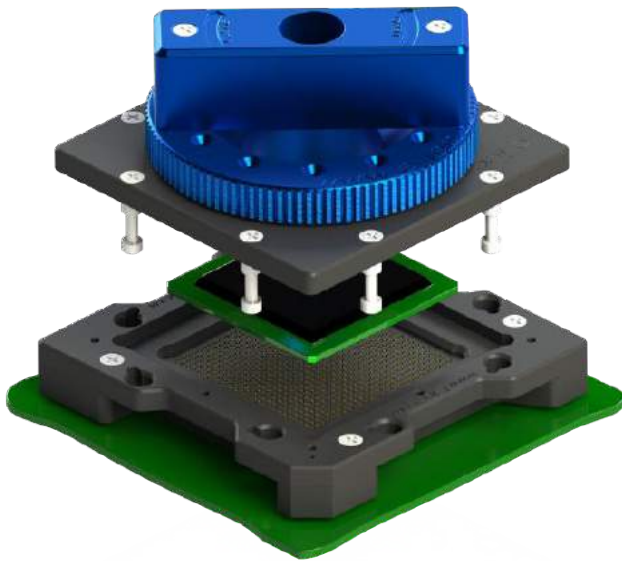
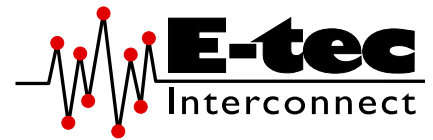

**E-tec Interconnect AG is the world leading Test socket manufacturer**

The SMT socket uses the same footprint as your chip. Socket is simply placed and reflowed onto the PCB in the same way as the chip and it only requires a small amount of additional board space. SMT type sockets are available with all retention systems. We aim to solve your requirements. Please note, we will always request the chip data to ensure we offer a compatible socket. For SMT sockets in general, E-tec Interconnect AG recommends the use of locating pegs, which can be soldered to the PCB for added mechanical strength.

Specifications contact type code 0530			
Application	Surface mouting	Force	30 gr
Mounting	SMT	Current rating	1 A
Bandwidth (GHz@-1dB)	2.7 GHz	Capacitance pF	< 1 pF
Contact resistance	<100mOhm	Inductance nH	< 2 nH
Chip contact tip shape	Single Point tip or Concave tip	Temperature range	-55°C to +150°C
PCB tip shape	SMT	Mating cycles	100 K

## How to order

**LP # #### -0530 - ##### 95 #**

<p><b>Shape of tip</b></p> <p>P : Pointed</p> <p><b>Options:</b></p> <p>C : Crown</p>	<p><b>Nbr of contacts</b></p> <p>Depends on ballcount of chip</p>	<p><b>Contact type</b></p> <p>30 : Standard SMT – Dimension A = 0.40 mm</p>	<p><b>Plating</b></p> <p>95 : Tin / Gold</p> <p>Other on request</p>	<p><b>Option code</b> (see page 16-19)</p> <p>D : Dead bug</p> <p>M : Multi frames</p> <p>U : Multi packages</p> <p>C : Converter plate</p> <p>S : Custom opening slot</p> <p>L : Locating pegs</p> <p>H : Heatsink</p> <p>F : Fan + Heatsink</p> <p>P : Thermal drain pad</p> <p>W : Transparent lid</p> <p>I : Steel retention lid</p> <p>B : Aluminium retention lid</p> <p>G : Handling button</p>
<p><b>Retention frame type (Lid)</b> (see page 12-15)</p> <p>W: TwistLock</p> <p>F : FastLock</p> <p>B : SpringLock</p> <p>H : Open Clamshell Alu (&lt;200 contacts)</p> <p>J : Clamshell Alu (&gt;200 contacts)</p> <p>L : Open Lever Clamshell Alu (&gt;200 contacts)</p>		<p><b>Grid code / Config. code</b></p> <p>Will be given by the factory after receipt of the chip datasheet</p>		
		<p>S : ScrewLock</p> <p>Q : Open QuickLock (&lt;200 contacts)</p> <p>D : QuickLock (&gt;200 contacts)</p> <p>M : Injection Molded ClamShell</p> <p>R : ReverseLock</p> <p>T : SlimLock</p>		



# Raised SMT soldering Test Socket

For LGA / QFN / MLF / MLP / LCC Package

0.50 mm pitch (from 0.50 mm up to 0.79 mm)

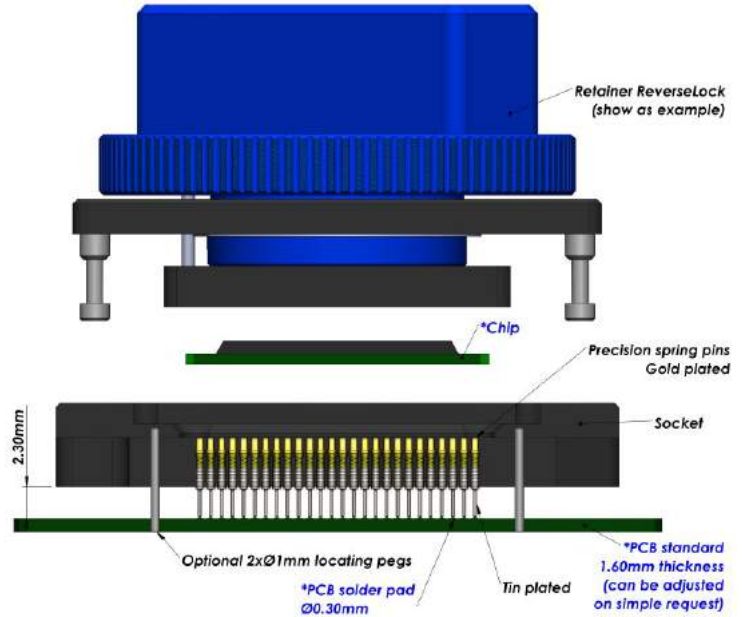
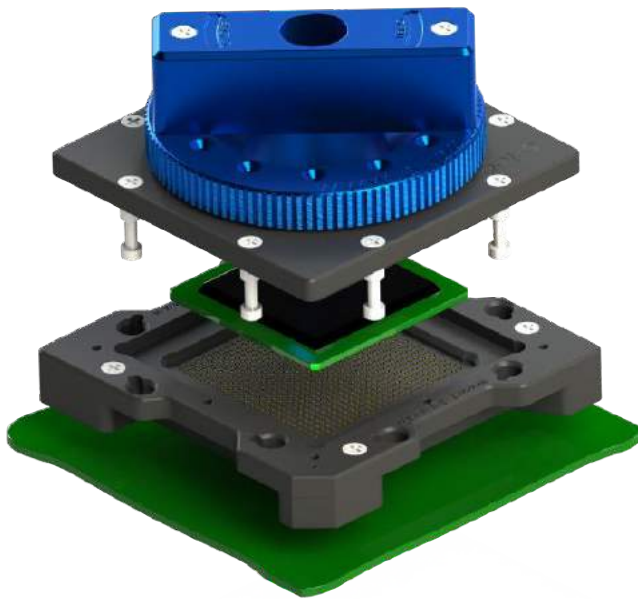
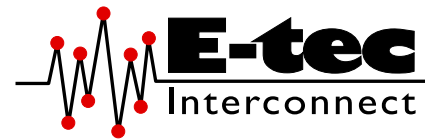

## E-tec Interconnect AG is the world leading Test socket manufacturer

The Raised SMT socket lifts the socket above close-by components on PCB and uses the same footprint as your chip. Socket is simply placed and reflowed onto the PCB in the same way as the chip and it only requires a small amount of additional board space. Raised SMT sockets are available with all retention systems. We aim to solve your requirements. Please note, we will always request the chip data to ensure we offer a compatible socket. For Raised SMT sockets in general, E-tec Interconnect AG recommends the use of locating pegs, which can be soldered to the PCB for added mechanical strength.

Specifications contact type code 0529			
Application	Surface mouting	Force	30 gr
Mounting	Raised SMT	Current rating	1 A
Bandwidth (GHz@-1dB)	na	Capacitance pF	na
Contact resistance	<100mOhm	Inductance nH	na
Chip contact tip shape	Single Point tip or Concave tip	Temperature range	-55°C to +150°C
PCB tip shape	Raised SMT	Mating cycles	100 K

## How to order

**LP # #### -0529 - ##### 95A #**

<p><b>Shape of tip</b></p> <p>P : Pointed</p> <p><b>Options:</b></p> <p>C : Crown</p>	<p><b>Nbr of contacts</b></p> <p>Depends on ballcount of chip</p>	<p><b>Contact type</b></p> <p>29 : Raised SMT – Dimension A = 2.30 mm</p>	<p><b>Plating</b></p> <p>95A: Tin/Gold + Alignment plate</p> <p>Other on request</p>	<p><b>Option code</b> (see page 16-19)</p> <p>D : Dead bug</p> <p>M : Multi frames</p> <p>U : Multi packages</p> <p>C : Converter plate</p> <p>S : Custom opening slot</p> <p>L : Locating pegs</p> <p>H : Heatsink</p> <p>F : Fan + Heatsink</p> <p>P : Thermal drain pad</p> <p>W : Transparent lid</p> <p>I : Steel retention lid</p> <p>B : Aluminium retention lid</p> <p>T : Torque tool fixture</p> <p>G : Handling button</p>
<p><b>Retention frame type (Lid)</b> (see page 12-15)</p> <p>W: TwistLock</p> <p>F : FastLock</p> <p>B : SpringLock</p> <p>H : Open Clamshell Alu (&lt;200 contacts)</p> <p>J : Clamshell Alu (&gt;200 contacts)</p> <p>L : Open Lever Clamshell Alu (&gt;200 contacts)</p>		<p>S : ScrewLock</p> <p>Q : Open QuickLock (&lt;200 contacts)</p> <p>D : QuickLock (&gt;200 contacts)</p> <p>M : Injection Molded ClamShell</p> <p>R : ReverseLock</p> <p>T : SlimLock</p>		<p><b>Grid code / Config. code</b></p> <p>Will be given by the factory after receipt of the chip datasheet</p>





# Probe Pin Solderless Compression Test Socket

For LGA / QFN / MLF / MLP / LCC Package

0.50 mm pitch (from 0.50 mm to 0.79 mm)

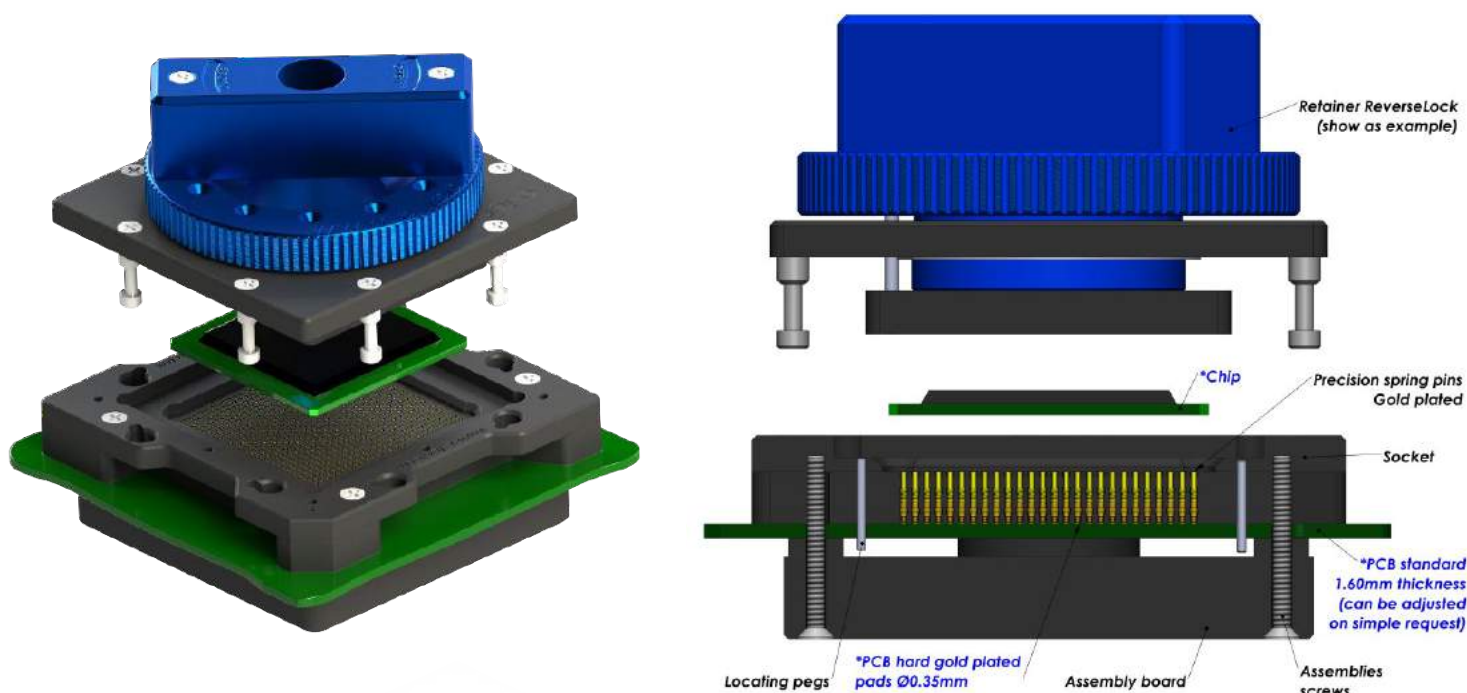
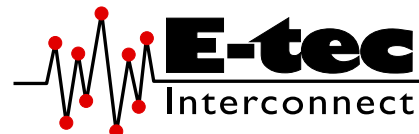

**E-tec Interconnect AG is the world leading Test socket manufacturer**

Probe Pin (Pogo) Solderless compression Test Sockets type are available for any chip size and pitch and are attached with 2, 4 or 8 screws to the PCB. The assembly board ensures perfect coplanarity of the socket. Contact reliability is guaranteed with spring loaded gold plated contacts, which are pressed onto gold plated PCB pads. Probe Pin (Pogo) Solderless compression type sockets are available with all retention systems. We aim to solve your requirements. Please note, we will always request the chip data to ensure we offer a compatible socket.

Contacts Specifications						
Contact type code	0590	0591	0592	0593	0594	0598
Application	Standard	Long live	High Frequency	High Temp & Long live	High Power	SuperHigh Frequency
Mounting	Solderless	Solderless	Solderless	Solderless	Solderless	Solderless
Bandwidth (GHz@-1dB)	3 GHz	7 GHz	29 GHz	8.9 GHz	9 GHz	40 GHz
Contact resistance	<100 mOhm	40 mOhm	100 mOhm	80 mOhm	80 mOhm	100 mOhm
Chip contact tip shape	Single Point tip Concave tip	Crown tip	Single Point tip	Crown tip	Crown tip	Single Point tip
PCB tip shape	Single Point tip	Single Point tip	Single Point tip	Single Point tip	Single Point tip	Spring
Force	30 gr	23 gr	20 gr	23 gr	30 gr	20 gr
Current rating	1.5 A	1 A	1.5 A	2 A	2 A	0.5 A
Capacitance pF	<1 pF	0.45 pF	0.48 pF	0.71 pF	na	0.36 pF
Inductance nH	<2 nH	1.08 nH	0.89 nH	0.67 nH	na	1.19 nH
Impedance Ohms	38 Ω	39 Ω	38 Ω	55 Ω	60 Ω	62 Ω
Temperature range	-55°C to +150°C	-50°C to +150°C	-40°C to +120°C	-50°C to +220°C	-50°C to +220°C	-55°C to +150°C
Mating cycles	100 K	300 K	100 K	500 K	500 K	100 K

More on the next page



# Probe Pin Solderless Compression Test Socket

For LGA / QFN / MLF / MLP / LCC Package

0.50 mm pitch (from 0.50 mm to 0.79 mm)

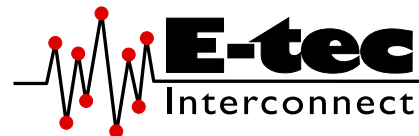

## Standard assembly boards

Small Chip size



Medium Chip size

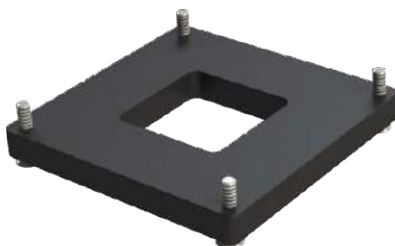

Large Chip size

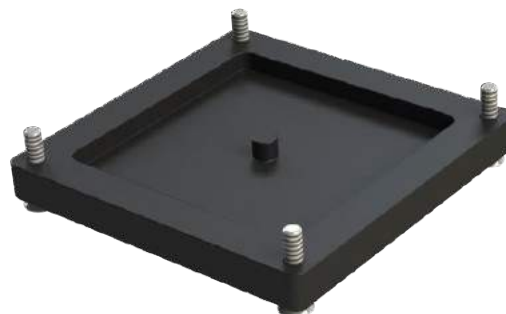

## Custom assembly boards

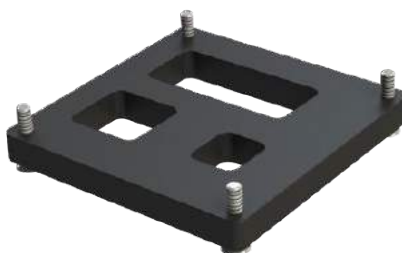
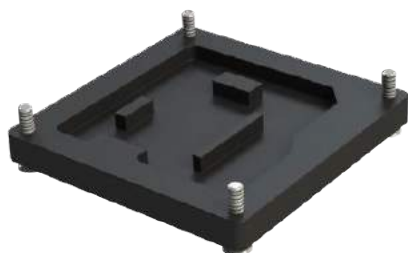

## How to order

**LP # # # # # -059# - # # # # # # 55L #**

**Shape of tip**  
**P** : Pointed  
**Options:**  
**C** : Crown

**Nbr of contacts**  
 Depends on ballcount of chip

**Contact type**  
**91 to 98** : See "Contacts specification" chart  
**90** : Standard solderless compression style  
**9M** : Special mixed contact style

**Plating**  
**55L**: Gold + Locating pegs  
 Other on request

**Option code** (see page 16-19)  
**D** : Dead bug  
**M** : Multi frames  
**U** : Multi packages  
**C** : Converter plate  
**S** : Custom opening slot  
**H** : Heatsink  
**F** : Fan + Heatsink  
**P** : Thermal drain pad  
**W** : Transparent lid  
**I** : Steel retention lid  
**B** : Aluminium retention lid  
**T** : Torque tool fixture  
**G** : Handling button

**Retention frame type (Lid)** (see page 12-15)

<b>W</b> : TwistLock	<b>S</b> : ScrewLock
<b>F</b> : FastLock	<b>Q</b> : Open QuickLock (<200 contacts)
<b>B</b> : SpringLock	<b>D</b> : QuickLock (>200 contacts)
<b>H</b> : Open Clamshell Alu (<200 contacts)	<b>M</b> : Injection Molded ClamShell
<b>J</b> : Clamshell Alu (>200 contacts)	<b>R</b> : ReverseLock
<b>L</b> : Open Lever Clamshell Alu (>200 contacts)	<b>T</b> : SlimLock

**Grid code / Config. code**  
 Will be given by the factory after receipt of the chip datasheet



# Elastomer Solderless Compression Test Socket

For LGA / QFN / MLF / MLP / LCC Package

0.50 mm pitch (from 0.50 mm to 0.79 mm)

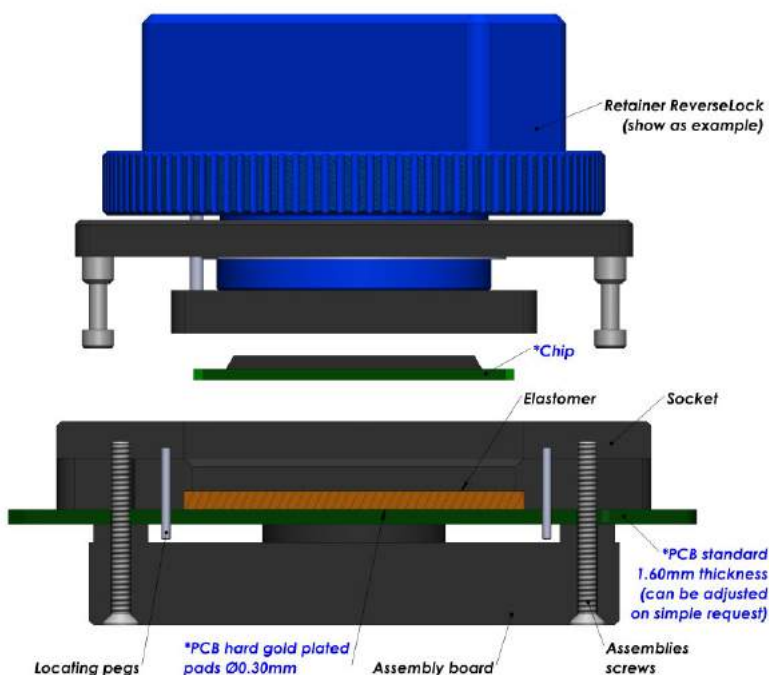
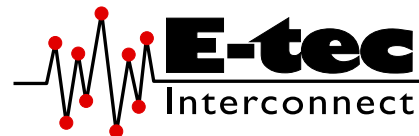

## E-tec Interconnect AG is the world leading Test socket manufacturer

The Elastomer Solderless compression Test Sockets are ideal technical solution for good signal integrity with low signal loss. The sockets are available for any chip size and pitch and are attached with 2, 4 or 8 screws to the PCB. The socket outline will be kept to a minimum and special clearances can be offered to avoid components on the PCB.

SMT and thru-hole sockets are available in certain pitches (contact factory for availability first) with these elastomer interposers to allow using this high frequency interposer on PCB's which have already been laid out for SMT or thru-hole sockets. We aim to solve your requirements. Please note, we will always request the chip data to ensure we offer a compatible socket.

Contacts Specifications			
Contact type code	E1	E2	E3
Application	High Frequency		
Mounting	Solderless	Solderless	Solderless
Bandwidth (GHz@-1dB)	17 GHz	34 GHz	>40 GHz
Contact resistance	30 mOhm		
Chip contact tip shape	Gold Wire		
PCB tip shape	Gold Wire		
Force	20 gr to 50 gr		
Current rating	2.5 A		
Capacitance pF	0.14 pF	0.10 pF	0.06 pF
Inductance nH	0.23 nH	0.30 nH	0.03 nH
Impedance Ohms	41.3 Ω	47.1 Ω	51.1 Ω
Temperature range	-40°C to +125°C		
Mating cycles	1 K		

More on the next page



# Elastomer Solderless Compression Test Socket

For LGA / QFN / MLF / MLP / LCC Package

0.50 mm pitch (from 0.50 mm to 0.79 mm)

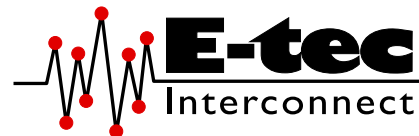

## Standard assembly boards

Small Chip size



Medium Chip size

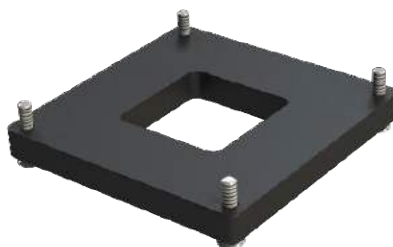

Large Chip size

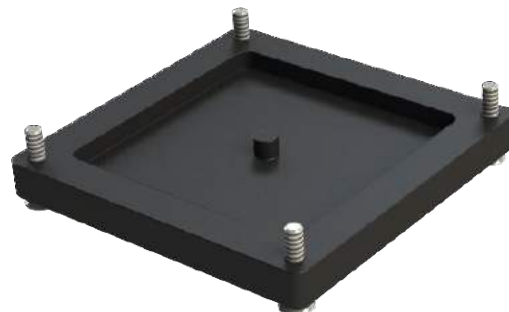

## Custom assembly boards

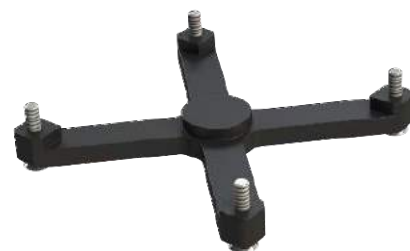
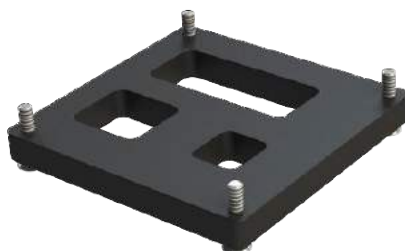
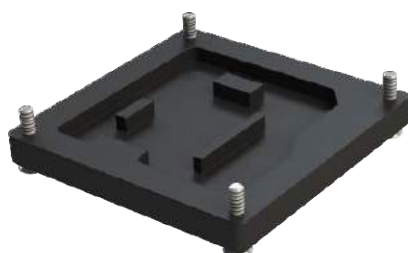

## How to order

**LE# #### -05E# - ##### 55L#**

<p><b>Shape of tip</b> E : Elastomer</p>	<p><b>Nbr of contacts</b> Depends on ballcount of chip</p>	<p><b>Contact type</b> E1 : High Frequency 17 GHz E2 : High Frequency 34 GHz E3 : High Frequency 40 GHz</p>	<p><b>Plating</b> 55L: Gold + Locating pegs</p>	<p><b>Option code</b> (see page 16-19) M : Multi frames U : Multi packages C : Converter plate S : Custom opening slot H : Heatsink F : Fan + Heatsink W : Transparent lid I : Steel retention lid B : Aluminium retention lid G : Handling button</p>
<p><b>Retention frame type (Lid)</b> (see page 12-15) W : TwistLock F : FastLock B : SpringLock H : Open Clamshell Alu (&lt;200 contacts) J : Clamshell Alu (&gt;200 contacts) L : Open Lever Clamshell Alu (&gt;200 contacts) S : ScrewLock Q : Open QuickLock (&lt;200 contacts) D : QuickLock (&gt;200 contacts) M : Injection Molded ClamShell R : ReverseLock T : SlimLock</p>		<p><b>Grid code / Config. code</b> Will be given by the factory after receipt of the chip datasheet</p>		







# Through-hole (THT) soldering Test Socket

For LGA / QFN / MLF / MLP / LCC Package

0.80 mm pitch (from 0.80 mm up to 0.99 mm)

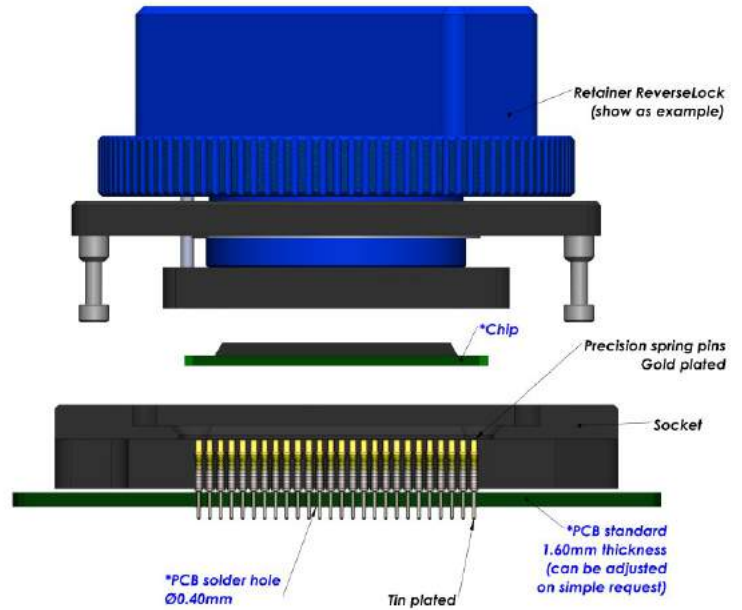
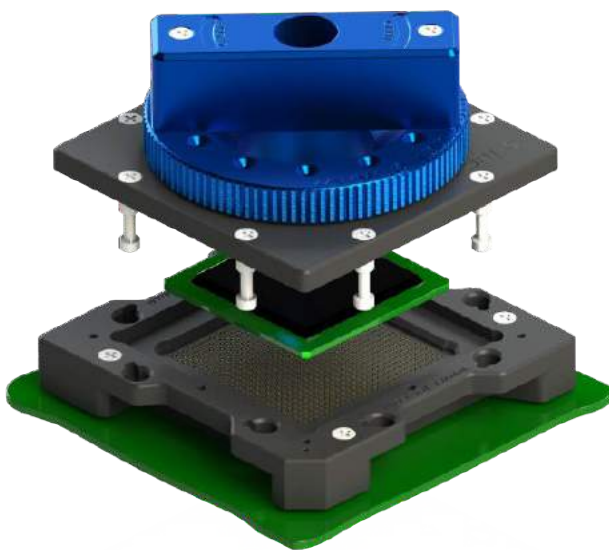

**E-tec Interconnect AG is the world leading Test socket manufacturer**

The Through-hole socket uses the same footprint as your chip. Socket is simply placed and wave soldered onto the PCB in the same way as the chip and it only requires a small amount of additional board space. Through-hole sockets are available with all retention systems. Please note, we will always request the chip data to ensure we offer a compatible socket.

Specifications contact type code 0870			
Application	Through-hole technology	Force	30 gr
Mounting	THT	Current rating	1.8 A
Bandwidth (GHz@-1dB)	3.4 GHz	Capacitance pF	0.59 pF
Contact resistance	<100mOhm	Inductance nH	1.70 nH
Chip contact tip shape	Single Point tip or Concave tip	Temperature range	-55°C to +150°C
PCB tip shape	Through-hole	Mating cycles	100 K

## How to order

**LP # #### -087# - ##### #5 #**

<p><b>Shape of tip</b></p> <p>P : Pointed</p> <p><b>Options:</b></p> <p>C : Crown</p>	<p><b>Nbr of contacts</b></p> <p>Depends on ballcount of chip</p>	<p><b>Contact type</b></p> <p>70 : Standard THT</p> <p>72 : Special THT to plug into MGS adapters</p>	<p><b>Plating</b></p> <p>95: Tin / Gold</p> <p>55: Gold/ Gold</p> <p>Other on request</p>	<p><b>Option code (see page 16-19)</b></p> <p>D : Dead bug</p> <p>M : Multi frames</p> <p>U : Multi packages</p> <p>C : Converter plate</p> <p>S : Custom opening slot</p> <p>L : Locating pegs</p> <p>A : Alignment plate</p> <p>H : Heatsink</p> <p>F : Fan + Heatsink</p> <p>P : Thermal drain pad</p> <p>W : Transparent lid</p> <p>I : Steel retention lid</p> <p>B : Aluminium retention lid</p> <p>T : Torque tool fixture</p> <p>G : Handling button</p>
<p><b>Retention frame type (Lid) (see page 12-15)</b></p> <p>W: TwistLock</p> <p>F: FastLock</p> <p>B: SpringLock</p> <p>H: Open Clamshell Alu (&lt;200 contacts)</p> <p>J: Clamshell Alu (&gt;200 contacts)</p> <p>L: Open Lever Clamshell Alu (&gt;200 contacts)</p>		<p><b>Grid code / Config. code</b></p> <p>Will be given by the factory after receipt of the chip datasheet</p>		
		<p>S : ScrewLock</p> <p>Q : Open QuickLock (&lt;200 contacts)</p> <p>D : QuickLock (&gt;200 contacts)</p> <p>M : Injection Molded ClamShell</p> <p>R : ReverseLock</p> <p>T : SlimLock</p>		



# Standard SMT soldering Test Socket

For LGA / QFN / MLF / MLP / LCC Package

0.80 mm pitch (from 0.80 mm up to 0.99 mm)

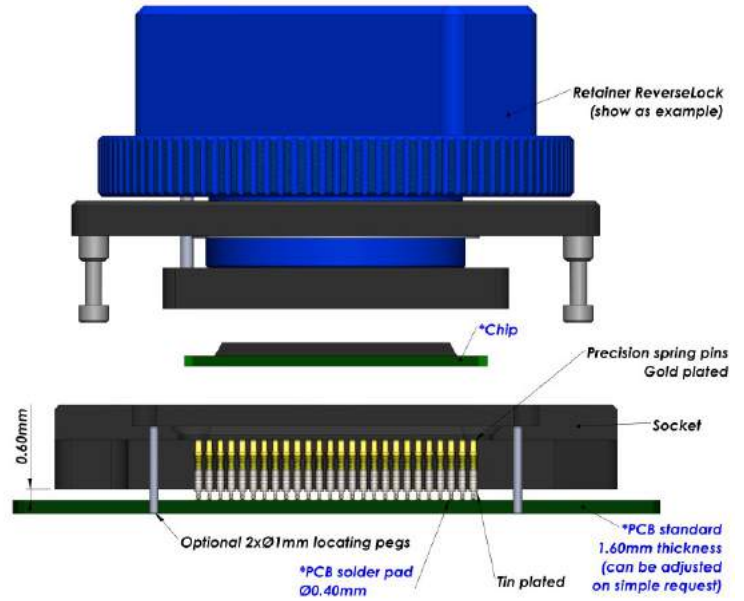
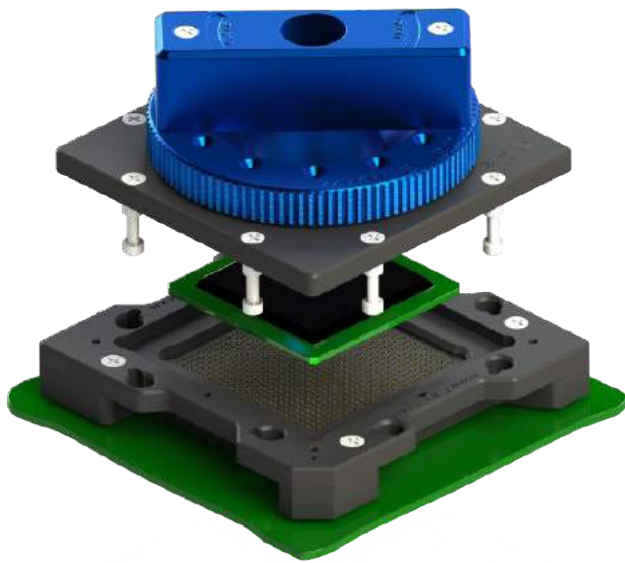
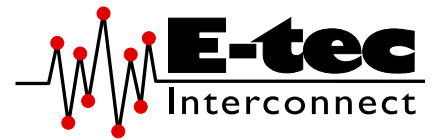

**E-tec Interconnect AG is the world leading Test socket manufacturer**

The SMT socket uses the same footprint as your chip. Socket is simply placed and reflowed onto the PCB in the same way as the chip and it only requires a small amount of additional board space. SMT type sockets are available with all retention systems. We aim to solve your requirements. Please note, we will always request the chip data to ensure we offer a compatible socket. For SMT sockets in general, E-tec Interconnect AG recommends the use of locating pegs, which can be soldered to the PCB for added mechanical strength.

Specifications contact type code 0830			
Application	Surface mouting	Force	30 gr
Mounting	SMT	Current rating	1.8 A
Bandwidth (GHz@-1dB)	2.6(4.4) GHz	Capacitance pF	0.59 pF
Contact resistance	<100mOhm	Inductance nH	1.70 nH
Chip contact tip shape	Single Point tip or Concave tip	Temperature range	-55°C to +150°C
PCB tip shape	SMT	Mating cycles	100 K

## How to order

**LP # #### -0830 - ##### 95 #**

### Shape of tip

P : Pointed

#### Options:

C : Crown

### Nbr of contacts

Depends on ballcount of chip

### Contact type

30 : Standard SMT – Dimension A = 0.60 mm

### Plating

95 : Tin / Gold

Other on request

### Option code (see page 16-19)

D : Dead bug

M : Multi frames

U : Multi packages

C : Converter plate

S : Custom opening slot

L : Locating pegs

H : Heatsink

F : Fan + Heatsink

P : Thermal drain pad

W : Transparent lid

I : Steel retention lid

B : Aluminium retention lid

G : Handling button

### Retention frame type (Lid) (see page 12-15)

W : TwistLock

F : FastLock

B : SpringLock

H : Open Clamshell Alu (<200 contacts)

J : Clamshell Alu (>200 contacts)

L : Open Lever Clamshell Alu (>200 contacts)

S : ScrewLock

Q : Open QuickLock (<200 contacts)

D : QuickLock (>200 contacts)

M : Injection Molded ClamShell

R : ReverseLock

T : SlimLock

### Grid code / Config. code

Will be given by the factory after receipt of the chip datasheet



# Raised SMT soldering Test Socket

For LGA / QFN / MLF / MLP / LCC Package

0.80 mm pitch (from 0.80 mm up to 0.99 mm)

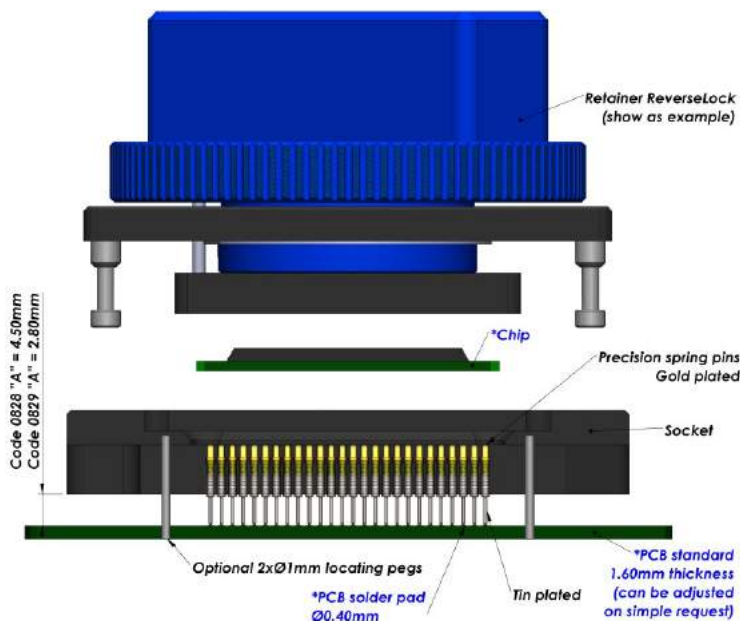
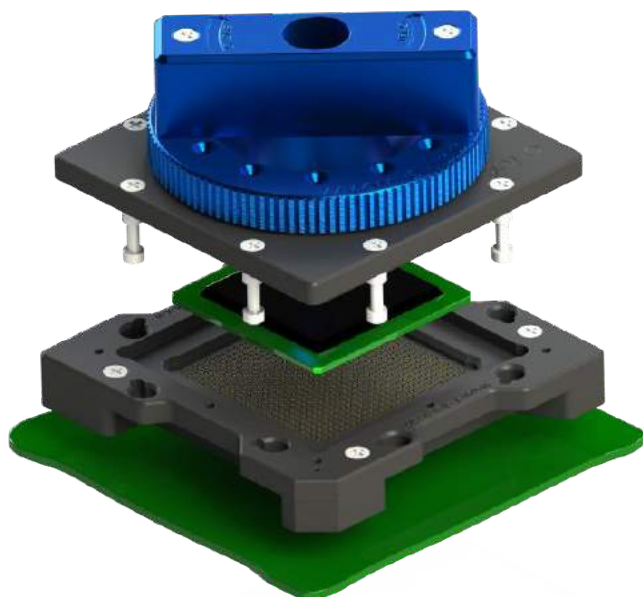
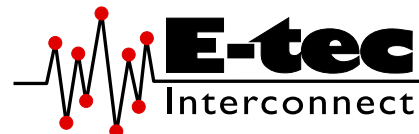

## E-tec Interconnect AG is the world leading Test socket manufacturer

The Raised SMT socket lifts the socket above close-by components on PCB and uses the same footprint as your chip. Socket is simply placed and reflowed onto the PCB in the same way as the chip and it only requires a small amount of additional board space. Raised SMT sockets are available with all retention systems. We aim to solve your requirements. Please note, we will always request the chip data to ensure we offer a compatible socket. For Raised SMT sockets in general, E-tec Interconnect AG recommends the use of locating pegs, which can be soldered to the PCB for added mechanical strength.

### Specifications contact type code 0829 & 0828

<b>Application</b>	Surface mouting	<b>Force</b>	30 gr
<b>Mounting</b>	Raised SMT	<b>Current rating</b>	1.8 A
<b>Bandwidth (GHz@-1dB)</b>	na	<b>Capacitance pF</b>	na
<b>Contact resistance</b>	<100mOhm	<b>Inductance nH</b>	na
<b>Chip contact tip shape</b>	Single Point tip or Concave tip	<b>Temperature range</b>	-55°C to +150°C
<b>PCB tip shape</b>	Raised SMT	<b>Mating cycles</b>	100 K

## How to order

**LP # #### -082# - ##### 95A #**

### Shape of tip

P : Pointed

#### Options:

C : Crown

### Nbr of contacts

Depends on ballcount of chip

### Contact type

29: Raised SMT – Dimension A = 2.80 mm

28: Special Raised SMT - Dim. A = 4.50 mm

### Plating

95A: Tin/Gold + Alignment plate

Other on request

### Option code (see page 16-19)

D : Dead bug

M : Multi frames

U : Multi packages

C : Converter plate

S : Custom opening slot

L : Locating pegs

H : Heatsink

F : Fan + Heatsink

P : Thermal drain pad

W : Transparent lid

I : Steel retention lid

B : Aluminium retention lid

T : Torque tool fixture

G : Handling button

### Retention frame type (Lid) (see page 12-15)

W: TwistLock

F : FastLock

B : SpringLock

H : Open Clamshell Alu (<200 contacts)

J : Clamshell Alu (>200 contacts)

L : Open Lever Clamshell Alu (>200 contacts)

S : ScrewLock

Q : Open QuickLock (<200 contacts)

D : QuickLock (>200 contacts)

M : Injection Molded ClamShell

R : ReverseLock

T : SlimLock

### Grid code / Config. code

Will be given by the factory after receipt of the chip datasheet



# Probe Pin Solderless Compression Test Socket

For LGA / QFN / MLF / MLP / LCC Package

0.80 mm pitch (from 0.80 mm to 0.99 mm)

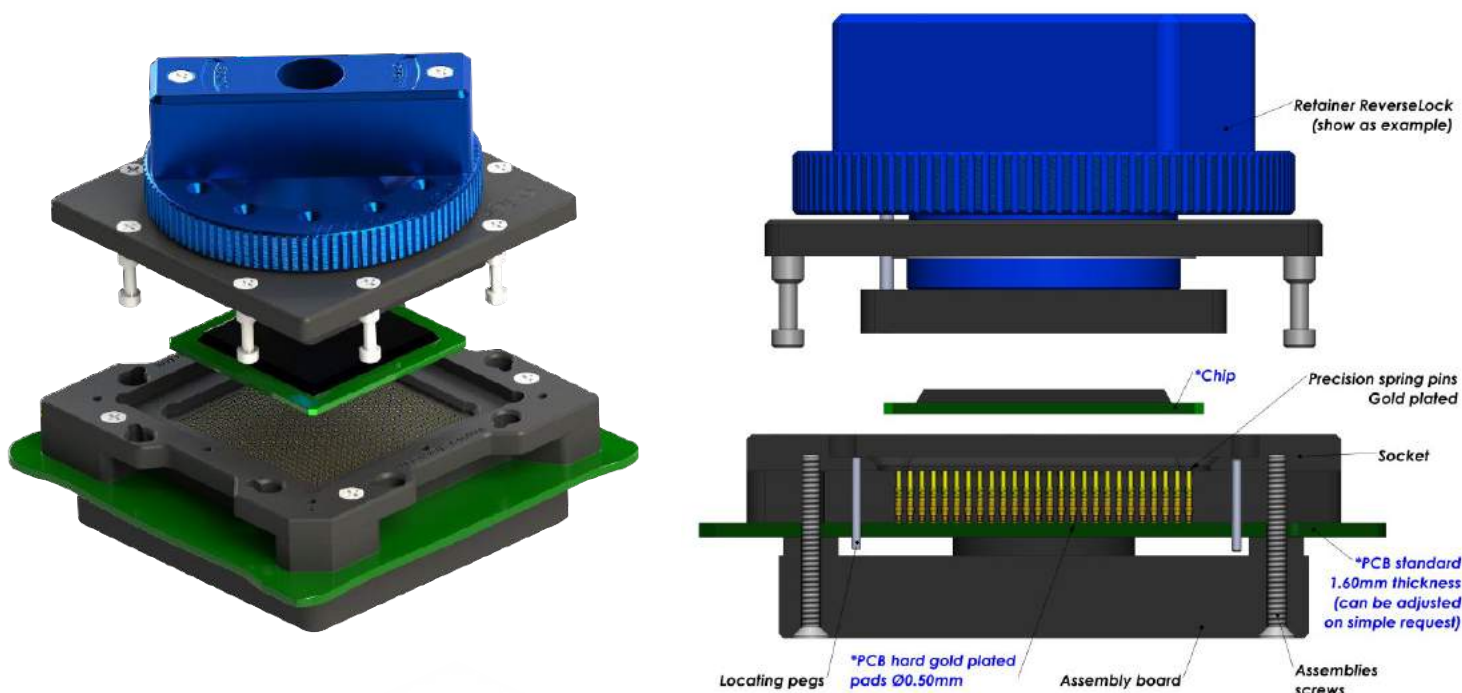
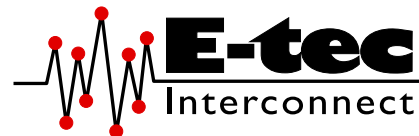

**E-tec Interconnect AG is the world leading Test socket manufacturer**

Probe Pin (Pogo) Solderless compression Test Sockets type are available for any chip size and pitch and are attached with 2, 4 or 8 screws to the PCB. The assembly board ensures perfect coplanarity of the socket. Contact reliability is guaranteed with spring loaded gold plated contacts, which are pressed onto gold plated PCB pads. Probe Pin (Pogo) Solderless compression type sockets are available with all retention systems. We aim to solve your requirements. Please note, we will always request the chip data to ensure we offer a compatible socket.

Contacts Specifications						
Contact type code	0890	0891	0893	0892	0894	0898
Application	Standard	High Frequency	Low Contact Resistance	High Frequency	Frequency	Frequency
Mounting	Solderless	Solderless	Solderless	Solderless	Solderless	Solderless
Bandwidth (GHz@-1dB)	3.4 GHz	36 GHz	7 GHz	31 GHz	14 GHz	31.7 GHz
Contact resistance	<100 mOhm	100 mOhm	40 mOhm	90 mOhm	90 mOhm	25 mOhm
Chip contact tip shape	Single Point tip Concave tip	Single Point tip	Crown tip	Single Point tip	Single Point tip	Single Point tip
PCB tip shape	Single Point tip	Single Point tip	Single Point tip	Spring	Spring	Spring
Force	30 gr	33 gr	23 gr	20 gr	20 gr	25 gr
Current rating	1.8 A	1 A	1 A	0.5 A	0.5 A	2.6 A
Capacitance pF	<1 pF	0.47 pF	0.55 pF	0.37 pF	0.30 pF	0.60 pF
Inductance nH	<2 nH	0.93 nH	1.08 nH	1.67 nH	1.66 nH	1.38 nH
Impedance Ohms	40 Ω	38 Ω	39 Ω	73 Ω	78 Ω	44.8 Ω
Temperature range	-55°C to +150°C	-40°C to +120°C	-50°C to +150°C	-55°C to +150°C	-55°C to +150°C	-55°C to +150°C
Mating cycles	100 K	100 K	100 K	100 K	100 K	100 K

More on the next page





# Probe Pin Solderless Compression Test Socket

For LGA / QFN / MLF / MLP / LCC Package

0.80 mm pitch (from 0.80 mm to 0.99 mm)

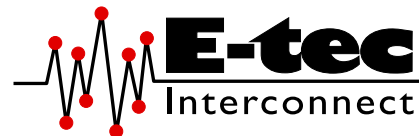

## Standard assembly boards

Small Chip size



Medium Chip size

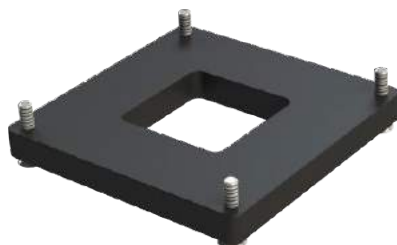

Large Chip size



## Custom assembly boards

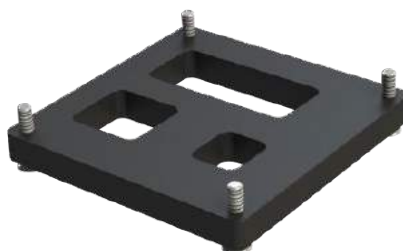
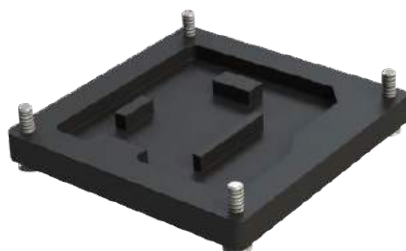

## How to order

**LP # # # # # -089# - # # # # # # 55L #**

**Shape of tip**  
**P** : Pointed  
**Options:**  
**C** : Crown

**Nbr of contacts**  
 Depends on ballcount of chip

**Contact type**  
**91 to 98** : See "Contacts specification" chart  
**90** : Standard solderless compression style  
**9M** : Special mixed contact style

**Plating**  
**55L**: Gold + Locating pegs  
 Other on request

**Option code** (see page 16-19)  
**D** : Dead bug  
**M** : Multi frames  
**U** : Multi packages  
**C** : Converter plate  
**S** : Custom opening slot  
**H** : Heatsink  
**F** : Fan + Heatsink  
**P** : Thermal drain pad  
**W** : Transparent lid  
**I** : Steel retention lid  
**B** : Aluminium retention lid  
**T** : Torque tool fixture  
**G** : Handling button

**Retention frame type (Lid)** (see page 12-15)

<b>W</b> : TwistLock	<b>S</b> : ScrewLock
<b>F</b> : FastLock	<b>Q</b> : Open QuickLock (<200 contacts)
<b>B</b> : SpringLock	<b>D</b> : QuickLock (>200 contacts)
<b>H</b> : Open Clamshell Alu (<200 contacts)	<b>M</b> : Injection Molded ClamShell
<b>J</b> : Clamshell Alu (>200 contacts)	<b>R</b> : ReverseLock
<b>L</b> : Open Lever Clamshell Alu (>200 contacts)	<b>T</b> : SlimLock

**Grid code / Config. code**  
 Will be given by the factory after receipt of the chip datasheet





# Elastomer Solderless Compression Test Socket

For LGA / QFN / MLF / MLP / LCC Package

0.80 mm pitch (from 0.80 mm to 0.99 mm)

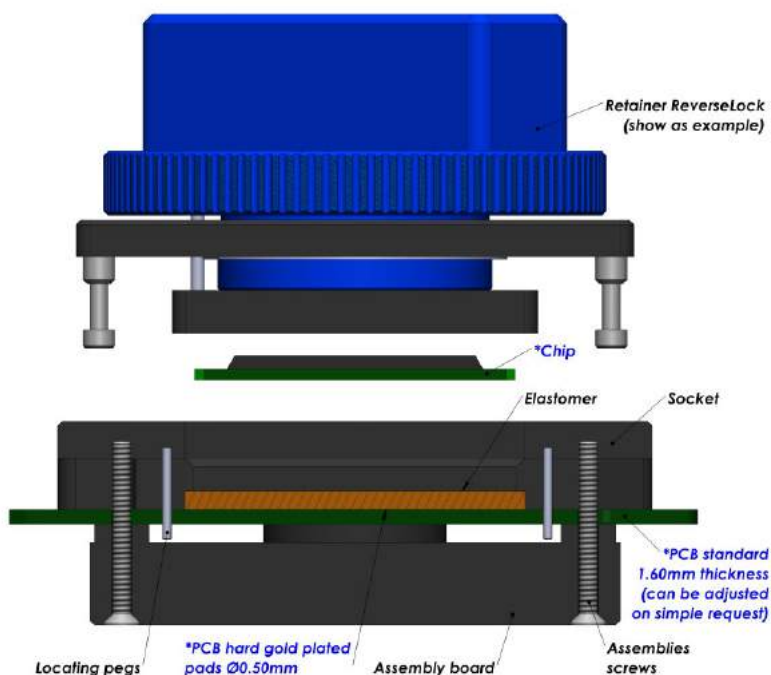
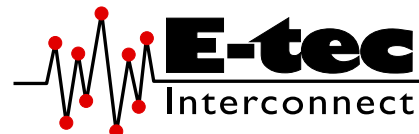

## E-tec Interconnect AG is the world leading Test socket manufacturer

The Elastomer Solderless compression Test Sockets are ideal technical solution for good signal integrity with low signal loss. The sockets are available for any chip size and pitch and are attached with 2, 4 or 8 screws to the PCB. The socket outline will be kept to a minimum and special clearances can be offered to avoid components on the PCB.

SMT and thru-hole adapter sockets are available in certain pitches (contact factory for availability first) with these elastomer interposers to allow using this high frequency interposer on PCB's which have already been laid out for SMT or thru-hole sockets. We aim to solve your requirements. Please note, we will always request the chip data to ensure we offer a compatible socket.

Contacts Specifications		
Contact type code	E1	E2
Application	High Frequency	
Mounting	Solderless	Solderless
Bandwidth (GHz@-1dB)	23 GHz	24 GHz
Contact resistance	30 mOhm	
Chip contact tip shape	Gold Wire	
PCB tip shape	Gold Wire	
Force	20 gr to 50 gr	
Current rating	3 A	
Capacitance pF	0.26 pF	0.16 pF
Inductance nH	0.52 nH	0.26 nH
Impedance Ohms	44.8 Ω	44.4 Ω
Temperature range	-40°C to +125°C	
Mating cycles	1 K	

More on the next page



# Elastomer Solderless Compression Test Socket

For LGA / QFN / MLF / MLP / LCC Package

0.80 mm pitch (from 0.80 mm to 0.99 mm)

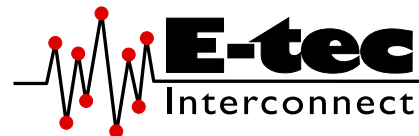

## Standard assembly boards

Small Chip size



Medium Chip size

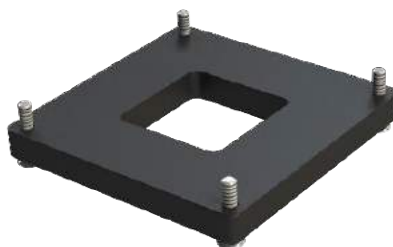

Large Chip size

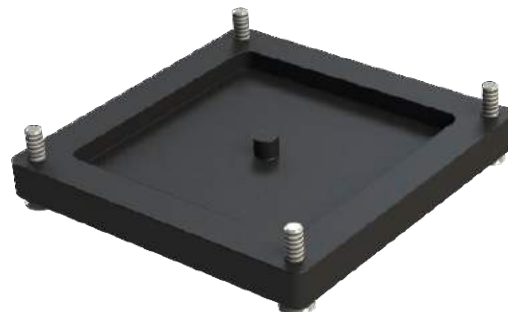

## Custom assembly boards

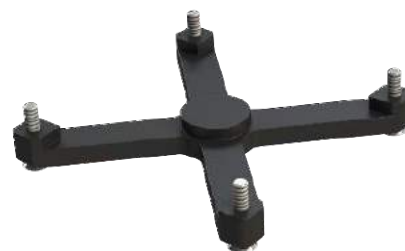
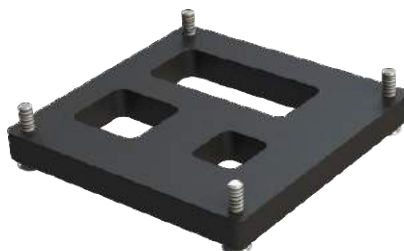

## How to order

**LE # #### -08E# - ##### 55L #**

**Shape of tip**  
E : Elastomer

**Nbr of contacts**  
Depends on ballcount of chip

**Contact type**  
E1 : High Frequency 23 GHz  
E2 : High Frequency 24 GHz

**Plating**  
55L: Gold + Locating pegs

**Option code** (see page 16-19)

- M : Multi frames
- U : Multi packages
- C : Converter plate
- S : Custom opening slot
- H : Heatsink
- F : Fan + Heatsink
- W : Transparent lid
- I : Steel retention lid
- B : Aluminium retention lid
- G : Handling button

**Retention frame type (Lid)** (see page 12-15)

- |  |                                    |
|--|------------------------------------|
| W : TwistLock                                | S : ScrewLock                      |
| F : FastLock                                 | Q : Open QuickLock (<200 contacts) |
| B : SpringLock                               | D : QuickLock (>200 contacts)      |
| H : Open Clamshell Alu (<200 contacts)       | M : Injection Molded ClamShell     |
| J : Clamshell Alu (>200 contacts)            | R : ReverseLock                    |
| L : Open Lever Clamshell Alu (>200 contacts) | T : SlimLock                       |

**Grid code / Config. code**  
Will be given by the factory after receipt of the chip datasheet





# Through-hole (THT) soldering Test Socket

For LGA / QFN / MLF / MLP / LCC Package

1.00 mm pitch (from 1.00 mm up to 1.26 mm)

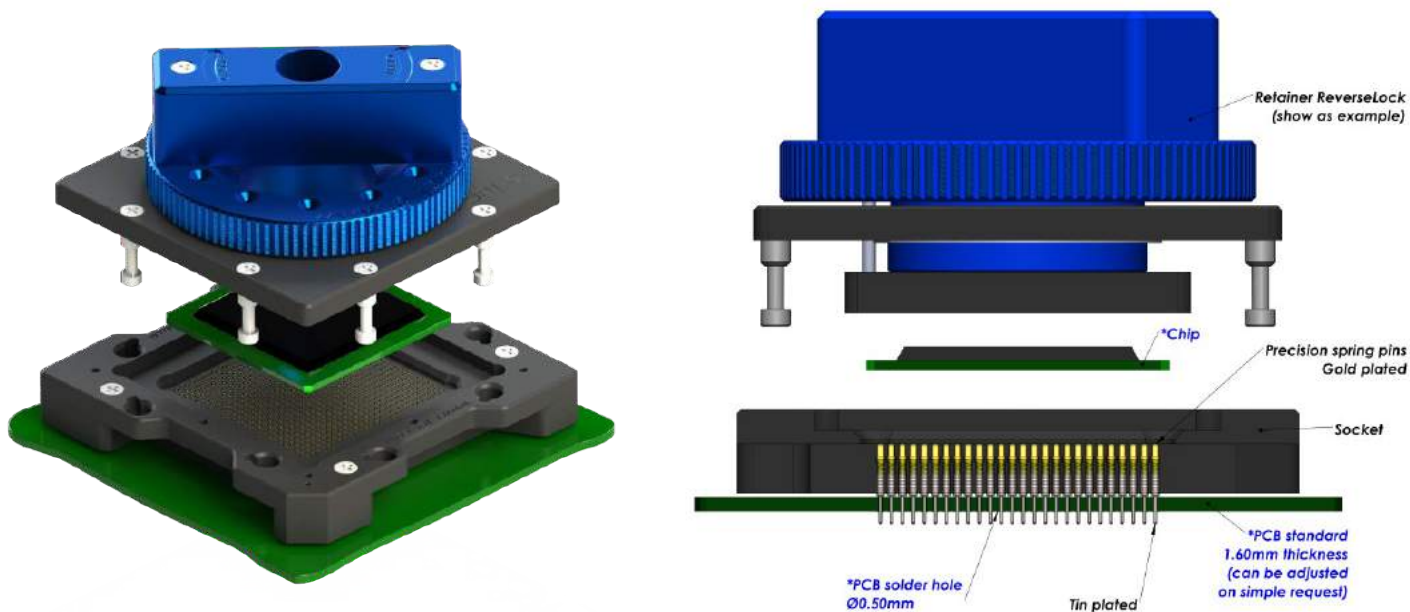

**E-tec Interconnect AG is the world leading Test socket manufacturer**

The Through-hole socket uses the same footprint as your chip. Socket is simply placed and wave soldered onto the PCB in the same way as the chip and it only requires a small amount of additional board space. Through-hole sockets are available with all retention systems. Please note, we will always request the chip data to ensure we offer a compatible socket.

Specifications contact type code 1070			
Application	Through-hole technology	Force	25 gr
Mounting	THT	Current rating	1.8 A
Bandwidth (GHz@-1dB)	3.4 GHz	Capacitance pF	1.03 pF
Contact resistance	<100mOhm	Inductance nH	1.80 nH
Chip contact tip shape	Single Point tip or Concave tip	Temperature range	-55°C to +150°C
PCB tip shape	Through-hole	Mating cycles	100 K

## How to order

**LP # #### -107# - ##### #5 #**

<p><b>Shape of tip</b></p> <p>P : Pointed</p> <p><b>Options:</b></p> <p>C : Crown</p>	<p><b>Nbr of contacts</b></p> <p>Depends on ballcount of chip</p>	<p><b>Contact type</b></p> <p>70 : Standard THT</p> <p>72 : Special THT to plug into MGS adapters</p>	<p><b>Plating</b></p> <p>95: Tin / Gold</p> <p>55: Gold/ Gold</p> <p>Other on request</p>	<p><b>Option code</b> (see page 16-19)</p> <p>D : Dead bug</p> <p>M : Multi frames</p> <p>U : Multi packages</p> <p>C : Converter plate</p> <p>S : Custom opening slot</p> <p>L : Locating pegs</p> <p>A : Alignment plate</p> <p>H : Heatsink</p> <p>F : Fan + Heatsink</p> <p>P : Thermal drain pad</p> <p>W : Transparent lid</p> <p>I : Steel retention lid</p> <p>B : Aluminium retention lid</p> <p>T : Torque tool fixture</p> <p>G : Handling button</p>
<p><b>Retention frame type (Lid)</b> (see page 12-15)</p> <p>W: TwistLock</p> <p>F: FastLock</p> <p>B: SpringLock</p> <p>H: Open Clamshell Alu (&lt;200 contacts)</p> <p>J: Clamshell Alu (&gt;200 contacts)</p> <p>L: Open Lever Clamshell Alu (&gt;200 contacts)</p>		<p><b>Grid code / Config. code</b></p> <p>Will be given by the factory after receipt of the chip datasheet</p>		
		<p>S : ScrewLock</p> <p>Q : Open QuickLock (&lt;200 contacts)</p> <p>D : QuickLock (&gt;200 contacts)</p> <p>M : Injection Molded ClamShell</p> <p>R : ReverseLock</p> <p>T : SlimLock</p>		

# Standard SMT soldering Test Socket

For LGA / QFN / MLF / MLP / LCC Package

1.00 mm pitch (from 1.00 mm up to 1.26 mm)

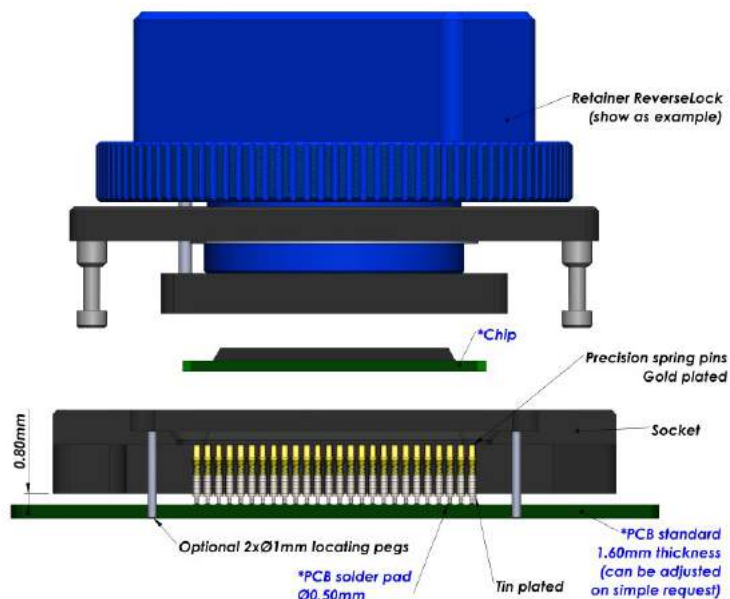
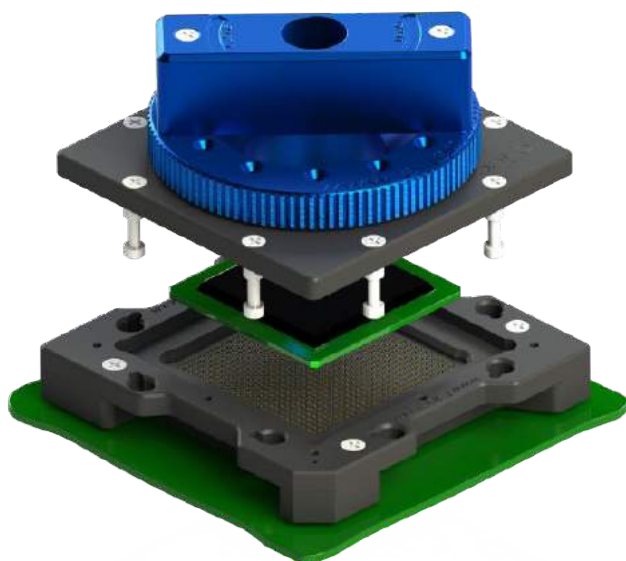
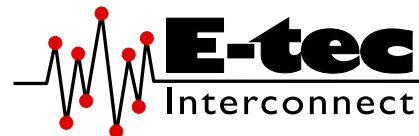

**E-tec Interconnect AG is the world leading Test socket manufacturer**

The SMT socket uses the same footprint as your chip. Socket is simply placed and reflowed onto the PCB in the same way as the chip and it only requires a small amount of additional board space. SMT type sockets are available with all retention systems. We aim to solve your requirements. Please note, we will always request the chip data to ensure we offer a compatible socket. For SMT sockets in general, E-tec Interconnect AG recommends the use of locating pegs, which can be soldered to the PCB for added mechanical strength.

Specifications contact type code 1030			
Application	Surface mouting	Force	25 gr
Mounting	SMT	Current rating	1.8 A
Bandwidth (GHz@-1dB)	2.8(6.6) GHz	Capacitance pF	0.62 pF
Contact resistance	<100mOhm	Inductance nH	1.97 nH
Chip contact tip shape	Single Point tip or Concave tip	Temperature range	-55°C to +150°C
PCB tip shape	SMT	Mating cycles	100 K

## How to order

**LP # #### -1030 - ##### 95 #**

<p><b>Shape of tip</b></p> <p>P : Pointed</p> <p><b>Options:</b></p> <p>C : Crown</p>	<p><b>Nbr of contacts</b></p> <p>Depends on ballcount of chip</p>	<p><b>Contact type</b></p> <p>30 : Standard SMT – Dimension A = 0.80 mm</p>	<p><b>Plating</b></p> <p>95 : Tin / Gold</p> <p>Other on request</p>	<p><b>Option code</b> (see page 16-19)</p> <p>D : Dead bug</p> <p>M : Multi frames</p> <p>U : Multi packages</p> <p>C : Converter plate</p> <p>S : Custom opening slot</p> <p>L : Locating pegs</p> <p>H : Heatsink</p> <p>F : Fan + Heatsink</p> <p>P : Thermal drain pad</p> <p>W : Transparent lid</p> <p>I : Steel retention lid</p> <p>B : Aluminium retention lid</p> <p>G : Handling button</p>
<p><b>Retention frame type (Lid)</b> (see page 12-15)</p> <p>W : TwistLock</p> <p>F : FastLock</p> <p>B : SpringLock</p> <p>H : Open Clamshell Alu (&lt;200 contacts)</p> <p>J : Clamshell Alu (&gt;200 contacts)</p> <p>L : Open Lever Clamshell Alu (&gt;200 contacts)</p>		<p>S : ScrewLock</p> <p>Q : Open QuickLock (&lt;200 contacts)</p> <p>D : QuickLock (&gt;200 contacts)</p> <p>M : Injection Molded ClamShell</p> <p>R : ReverseLock</p> <p>T : SlimLock</p>		<p><b>Grid code / Config. code</b></p> <p>Will be given by the factory after receipt of the chip datasheet</p>





# Raised SMT soldering Test Socket

For LGA / QFN / MLF / MLP / LCC Package

1.00 mm pitch (from 1.00 mm up to 1.26 mm)

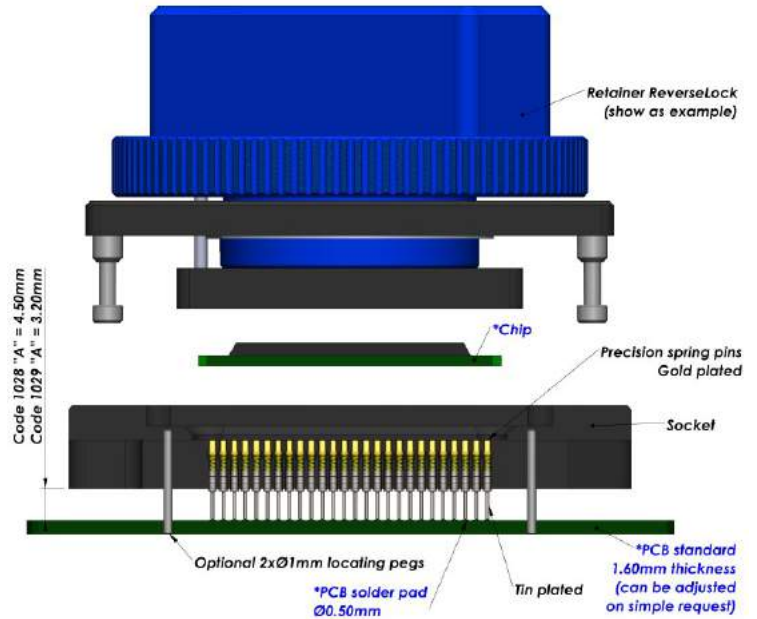
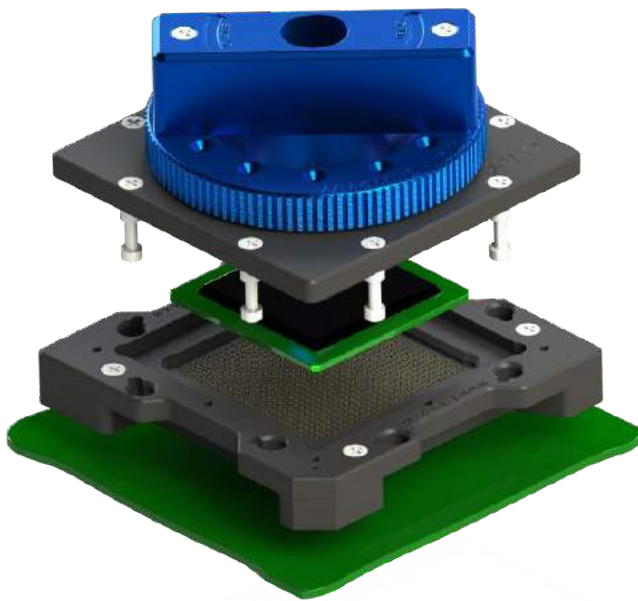
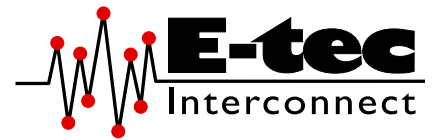

## E-tec Interconnect AG is the world leading Test socket manufacturer

The Raised SMT socket lifts the socket above close-by components on PCB and uses the same footprint as your chip. Socket is simply placed and reflowed onto the PCB in the same way as the chip and it only requires a small amount of additional board space. Raised SMT sockets are available with all retention systems. We aim to solve your requirements. Please note, we will always request the chip data to ensure we offer a compatible socket. For Raised SMT sockets in general, E-tec Interconnect AG recommends the use of locating pegs, which can be soldered to the PCB for added mechanical strength.

Specifications Contact type code 1029 & 1028			
Application	Surface mouting	Force	25 gr
Mounting	Raised SMT	Current rating	1.8 A
Bandwidth (GHz@-1dB)	na	Capacitance pF	na
Contact resistance	<100mOhm	Inductance nH	na
Chip contact tip shape	Single Point tip or Concave tip	Temperature range	-55°C to +150°C
PCB tip shape	Raised SMT	Mating cycles	100 K

## How to order

**LP # #### -102# - ##### 95A #**

<p><b>Shape of tip</b></p> <p>P : Pointed</p> <p><b>Options:</b></p> <p>C : Crown</p>	<p><b>Nbr of contacts</b></p> <p>Depends on ballcount of chip</p>	<p><b>Contact type</b></p> <p>29 : Raised SMT – Dimension A = 3.20 mm</p> <p>28 : Special Raised SMT - Dim. A = 4.50 mm</p>	<p><b>Plating</b></p> <p>95A: Tin/Gold + Alignment plate</p> <p>Other on request</p>	<p><b>Option code</b> (see page 16-19)</p> <p>D : Dead bug</p> <p>M : Multi frames</p> <p>U : Multi packages</p> <p>C : Converter plate</p> <p>S : Custom opening slot</p> <p>L : Locating pegs</p> <p>H : Heatsink</p> <p>F : Fan + Heatsink</p> <p>P : Thermal drain pad</p> <p>W : Transparent lid</p> <p>I : Steel retention lid</p> <p>B : Aluminium retention lid</p> <p>T : Torque tool fixture</p> <p>G : Handling button</p>
<p><b>Retention frame type (Lid)</b> (see page 12-15)</p> <p>W: TwistLock</p> <p>F : FastLock</p> <p>B : SpringLock</p> <p>H : Open Clamshell Alu (&lt;200 contacts)</p> <p>J : Clamshell Alu (&gt;200 contacts)</p> <p>L : Open Lever Clamshell Alu (&gt;200 contacts)</p>		<p><b>Grid code / Config. code</b></p> <p>Will be given by the factory after receipt of the chip datasheet</p>		
		<p>S : ScrewLock</p> <p>Q : Open QuickLock (&lt;200 contacts)</p> <p>D : QuickLock (&gt;200 contacts)</p> <p>M : Injection Molded ClamShell</p> <p>R : ReverseLock</p> <p>T : SlimLock</p>		



# Probe Pin Solderless Compression Test Socket

For LGA / QFN / MLF / MLP / LCC Package

1.00 mm pitch (from 1.00 mm to 1.26 mm)

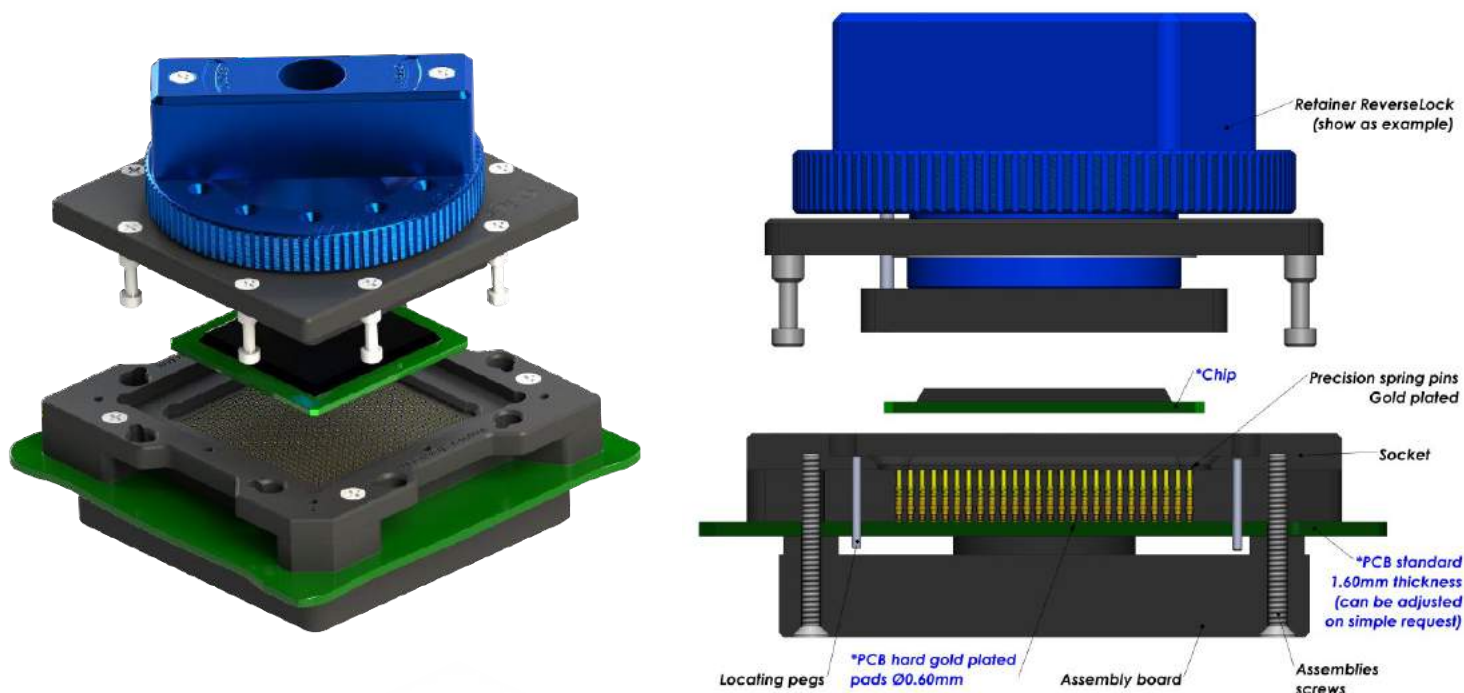
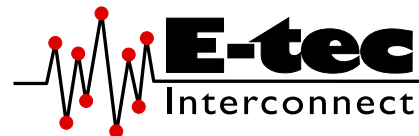

**E-tec Interconnect AG is the world leading Test socket manufacturer**

Probe Pin (Pogo) Solderless compression Test Sockets type are available for any chip size and pitch and are attached with 2, 4 or 8 screws to the PCB. The assembly board ensures perfect coplanarity of the socket. Contact reliability is guaranteed with spring loaded gold plated contacts, which are pressed onto gold plated PCB pads. Probe Pin (Pogo) Solderless compression type sockets are available with all retention systems. We aim to solve your requirements. Please note, we will always request the chip data to ensure we offer a compatible socket.

Contacts Specifications						
Contact type code	1090	1091	1092	1093	1094	1098
Application	Standard	Long Live	High Frequency	High Power	Frequency	Frequency
Mounting	Solderless	Solderless	Solderless	Solderless	Solderless	Solderless
Bandwidth (GHz@-1dB)	3 GHz	11 GHz	31 GHz	10 GHz	9.4 GHz	30.3 GHz
Contact resistance	<100 mOhm	45 mOhm	100 mOhm	30 mOhm	25 mOhm	25 mOhm
Chip contact tip shape	Single Point tip Concave tip	Crown tip	Single Point tip	Round tip	Single Point tip	Single Point tip
PCB tip shape	Single Point tip	Single Point tip	Single Point tip	Single Point tip	Spring	Spring
Force	25 gr	35 gr	33 gr	30 gr	25 gr	25 gr
Current rating	1.8 A	3 A	1 A	4 A	5 A	2.6 A
Capacitance pF	<1 pF	0.55 pF	0.39 pF	0.19 pF	0.85 pF	0.54 pF
Inductance nH	<2 nH	0.76 nH	1.01 nH	0.93 nH	1.36 nH	1.70 nH
Impedance Ohms	45 Ω	36 Ω	46 Ω	38 Ω	35 Ω	59.9 Ω
Temperature range	-55°C to +150°C	-40°C to +120°C	-50°C to +120°C	-55°C to +180°C	-55°C to +150°C	-55°C to +150°C
Mating cycles	100 K	300 K	100 K	125 K	100 K	100 K

More on the next page



# Probe Pin Solderless Compression Test Socket

For LGA / QFN / MLF / MLP / LCC Package

1.00 mm pitch (from 1.00 mm to 1.26 mm)

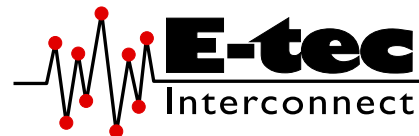

## Standard assembly boards

Small Chip size



Medium Chip size

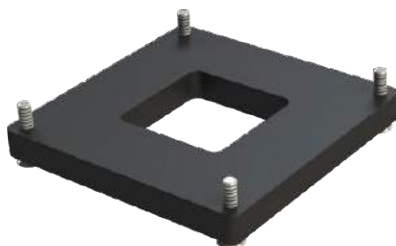

Large Chip size

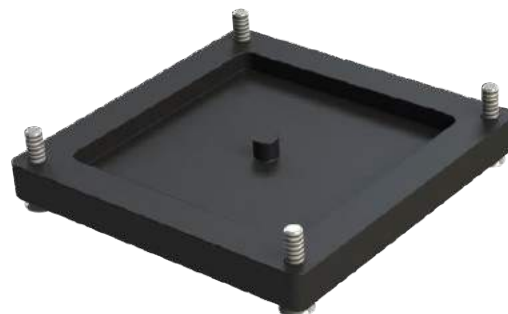

## Custom assembly boards

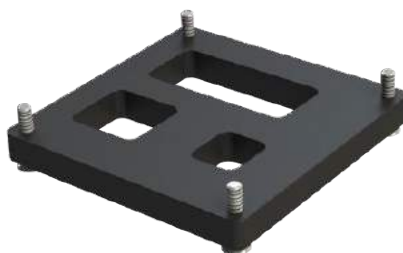
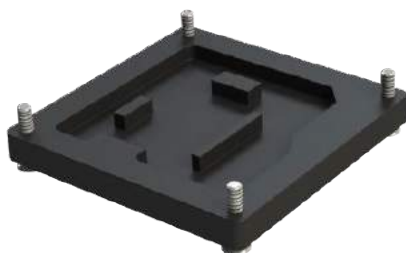

## How to order

**LP # # # # -109# - # # # # # 55L #**

<p><b>Shape of tip</b></p> <p><b>P</b> : Pointed</p> <p><b>Options:</b></p> <p><b>C</b> : Crown</p>	<p><b>Nbr of contacts</b></p> <p>Depends on ballcount of chip</p>	<p><b>Contact type</b></p> <p><b>91 to 98</b> : See "Contacts specification" chart</p> <p><b>90</b> : Standard solderless compression style</p> <p><b>9M</b>: Special mixed contact style</p>	<p><b>Plating</b></p> <p><b>55L</b>: Gold + Locating pegs</p> <p>Other on request</p>	<p><b>Option code</b> (see page 16-19)</p> <p><b>D</b> : Dead bug</p> <p><b>M</b> : Multi frames</p> <p><b>U</b> : Multi packages</p> <p><b>C</b> : Converter plate</p> <p><b>S</b> : Custom opening slot</p> <p><b>H</b> : Heatsink</p> <p><b>F</b> : Fan + Heatsink</p> <p><b>P</b> : Thermal drain pad</p> <p><b>W</b> : Transparent lid</p> <p><b>I</b> : Steel retention lid</p> <p><b>B</b> : Aluminium retention lid</p> <p><b>T</b> : Torque tool fixture</p> <p><b>G</b> : Handling button</p>
<p><b>Retention frame type (Lid)</b> (see page 12-15)</p> <p><b>W</b>: TwistLock</p> <p><b>F</b> : FastLock</p> <p><b>B</b> : SpringLock</p> <p><b>H</b> : Open Clamshell Alu (&lt;200 contacts)</p> <p><b>J</b> : Clamshell Alu (&gt;200 contacts)</p> <p><b>L</b> : Open Lever Clamshell Alu (&gt;200 contacts)</p> <p><b>S</b> : ScrewLock</p> <p><b>Q</b> : Open QuickLock (&lt;200 contacts)</p> <p><b>D</b> : QuickLock (&gt;200 contacts)</p> <p><b>M</b> : Injection Molded ClamShell</p> <p><b>R</b> : ReverseLock</p> <p><b>T</b> : SlimLock</p>		<p><b>Grid code / Config. code</b></p> <p>Will be given by the factory after receipt of the chip datasheet</p>		



# Elastomer Solderless Compression Test Socket

For LGA / QFN / MLF / MLP / LCC Package

1.00 mm pitch (from 1.00 mm to 1.26 mm)

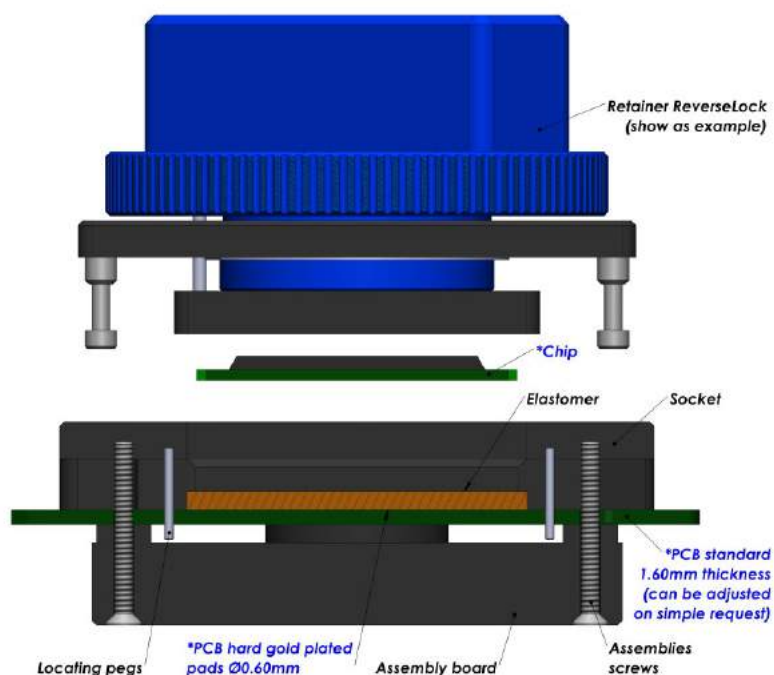
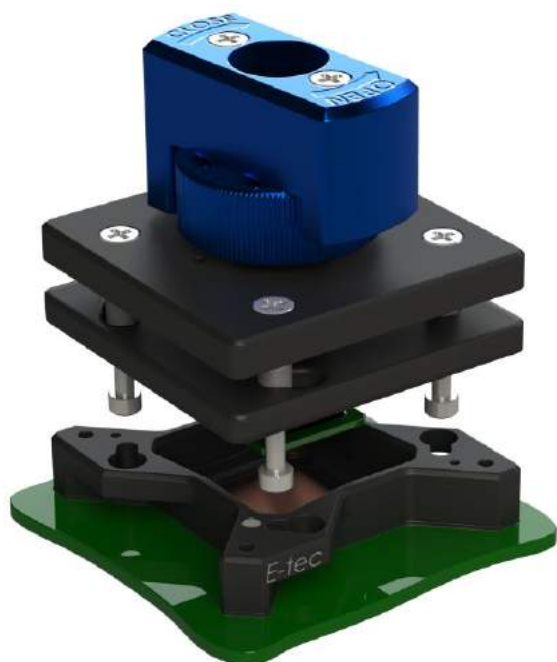
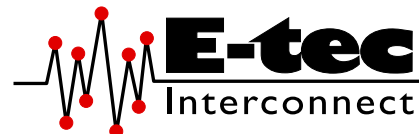

## E-tec Interconnect AG is the world leading Test socket manufacturer

The Elastomer Solderless compression Test Sockets are ideal technical solution for good signal integrity with low signal loss. The sockets are available for any chip size and pitch and are attached with 2, 4 or 8 screws to the PCB. The socket outline will be kept to a minimum and special clearances can be offered to avoid components on the PCB.

SMT and thru-hole adapter sockets are available in certain pitches (contact factory for availability first) with these elastomer interposers to allow using this high frequency interposer on PCB's which have already been laid out for SMT or thru-hole sockets. We aim to solve your requirements. Please note, we will always request the chip data to ensure we offer a compatible socket.

Contacts Specifications			
Contact type code	E1	E2	E3
Application	High Frequency		
Mounting	Solderless	Solderless	Solderless
Bandwidth (GHz@-1dB)	20 GHz	38 GHz	30 GHz
Contact resistance	30 mOhm		
Chip contact tip shape	Gold Wire		
PCB tip shape	Gold Wire		
Force	20 gr to 50 gr		
Current rating	3 A		
Capacitance pF	0.26 pF	0.12 pF	0.10 pF
Inductance nH	0.52 nH	0.35 nH	0.18 nH
Impedance Ohms	44.8 Ω	44.4 Ω	42.1 Ω
Temperature range	-40°C to +125°C		
Mating cycles	1 K		

More on the next page



# Elastomer Solderless Compression Test Socket

For LGA / QFN / MLF / MLP / LCC Package

1.00 mm pitch (from 1.00 mm to 1.26 mm)

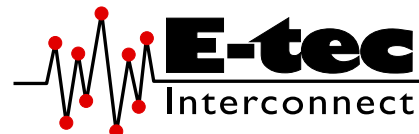

## Standard assembly boards

Small Chip size



Medium Chip size

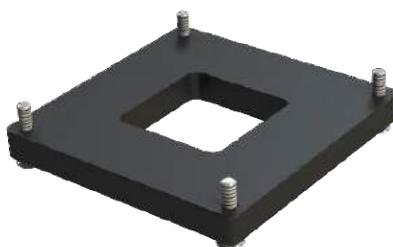

Large Chip size



## Custom assembly boards

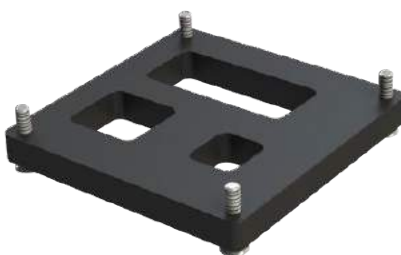
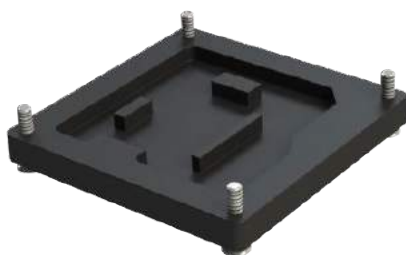

## How to order

**LE# #### -10E# - ##### 55L #**

<p><b>Shape of tip</b></p> <p>E : Elastomer</p>	<p><b>Nbr of contacts</b></p> <p>Depends on ballcount of chip</p>	<p><b>Contact type</b></p> <p>E1 : High Frequency 20 GHz E2 : High Frequency 38 GHz E3 : High Frequency 30 GHz</p>	<p><b>Plating</b></p> <p>55L: Gold + Locating pegs</p>	<p><b>Option code</b> (see page 16-19)</p> <p>M : Multi frames U : Multi packages C : Converter plate S : Custom opening slot H : Heatsink F : Fan + Heatsink W : Transparent lid I : Steel retention lid B : Aluminium retention lid G : Handling button</p>
<p><b>Retention frame type (Lid)</b> (see page 12-15)</p> <p>W: TwistLock F : FastLock B : SpringLock H : Open Clamshell Alu (&lt;200 contacts) J : Clamshell Alu (&gt;200 contacts) L : Open Lever Clamshell Alu (&gt;200 contacts)</p> <p>S : ScrewLock Q : Open QuickLock (&lt;200 contacts) D : QuickLock (&gt;200 contacts) M : Injection Molded ClamShell R : ReverseLock T : SlimLock</p>		<p><b>Grid code / Config. code</b></p> <p>Will be given by the factory after receipt of the chip datasheet</p>		





# Through-hole (THT) soldering Test Socket

For LGA / QFN / MLF / MLP / LCC Package

1.27 mm pitch (from 1.27 mm upwards)

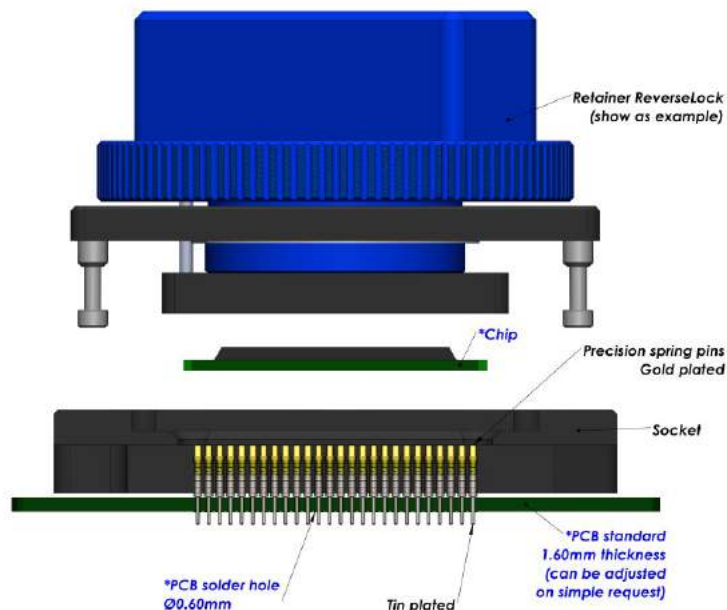
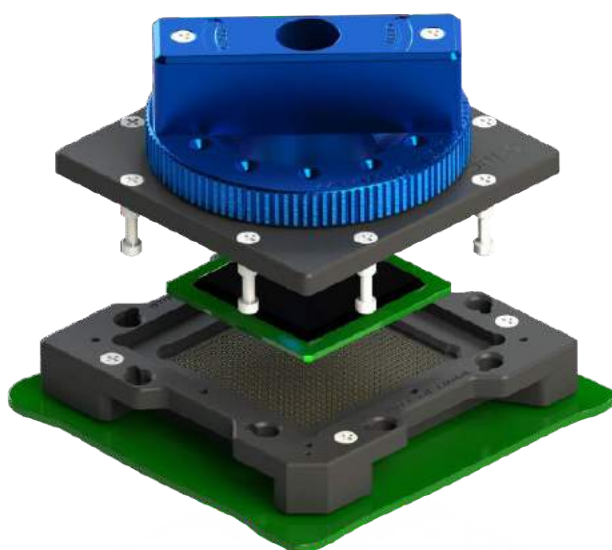

**E-tec Interconnect AG is the world leading Test socket manufacturer**

The Through-hole socket uses the same footprint as your chip. Socket is simply placed and wave soldered onto the PCB in the same way as the chip and it only requires a small amount of additional board space. Through-hole sockets are available with all retention systems. Please note, we will always request the chip data to ensure we offer a compatible socket.

Specifications contact type code 1270			
Application	Through-hole technology	Force	25 gr
Mounting	THT	Current rating	2.2 A
Bandwidth (GHz@-1dB)	3 GHz	Capacitance pF	< 1 pF
Contact resistance	<100mOhm	Inductance nH	< 2 nH
Chip contact tip shape	Single Point tip or Concave tip	Temperature range	-55°C to +150°C
PCB tip shape	Through-hole	Mating cycles	100 K

## How to order

**LP # #### -127# - ##### #5 #**

### Shape of tip

P : Pointed

#### Options:

C : Crown

### Nbr of contacts

Depends on ballcount of chip

### Contact type

70 : Standard THT

72 : Special THT to plug into MGS adapters

### Plating

95: Tin / Gold

55: Gold/ Gold

Other on request

### Option code (see page 16-19)

D : Dead bug

M : Multi frames

U : Multi packages

C : Converter plate

S : Custom opening slot

L : Locating pegs

A : Alignment plate

H : Heatsink

F : Fan + Heatsink

P : Thermal drain pad

W : Transparent lid

I : Steel retention lid

B : Aluminium retention lid

T : Torque tool fixture

G : Handling button

### Retention frame type (Lid) (see page 12-15)

W: TwistLock

F : FastLock

B : SpringLock

H : Open Clamshell Alu (<200 contacts)

J : Clamshell Alu (>200 contacts)

L : Open Lever Clamshell Alu (>200 contacts)

S : ScrewLock

Q : Open QuickLock (<200 contacts)

D : QuickLock (>200 contacts)

M : Injection Molded ClamShell

R : ReverseLock

T : SlimLock

### Grid code / Config. code

Will be given by the factory after receipt of the chip datasheet

# Standard SMT soldering Test Socket

For LGA / QFN / MLF / MLP / LCC Package

1.27 mm pitch (from 1.27 mm upwards)

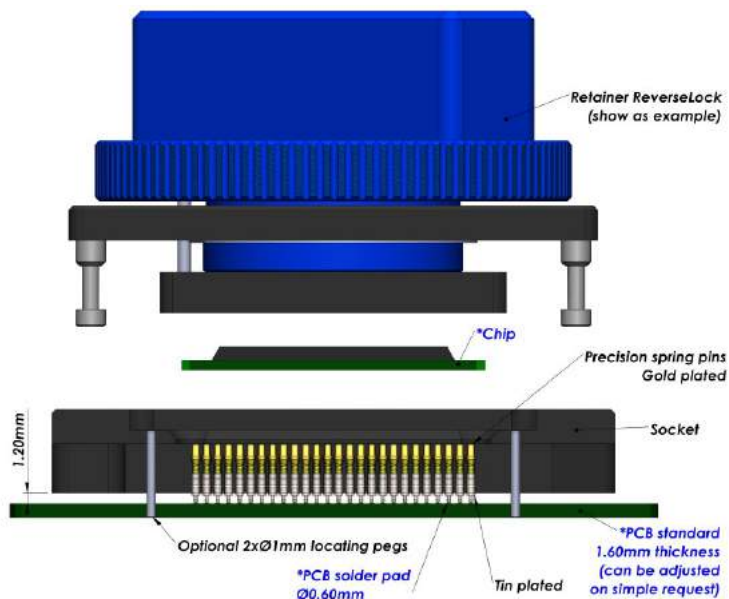
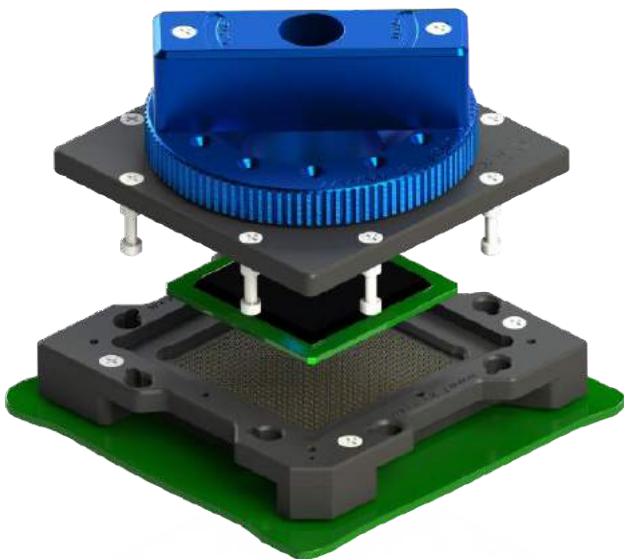
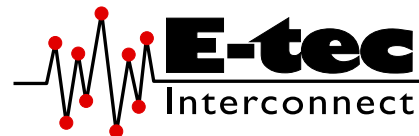

**E-tec Interconnect AG is the world leading Test socket manufacturer**

The SMT socket uses the same footprint as your chip. Socket is simply placed and reflowed onto the PCB in the same way as the chip and it only requires a small amount of additional board space. SMT type sockets are available with all retention systems. We aim to solve your requirements. Please note, we will always request the chip data to ensure we offer a compatible socket. For SMT sockets in general, E-tec Interconnect AG recommends the use of locating pegs, which can be soldered to the PCB for added mechanical strength.

Specifications contact type code 1230			
Application	Surface mouting	Force	25 gr
Mounting	SMT	Current rating	2.2 A
Bandwidth (GHz@-1dB)	3 GHz	Capacitance pF	< 1 pF
Contact resistance	<100mOhm	Inductance nH	< 2 nH
Chip contact tip shape	Single Point tip or Concave tip	Temperature range	-55°C to +150°C
PCB tip shape	SMT	Mating cycles	100 K

## How to order

**LP # #### -1230 - ##### 95 #**

<p><b>Shape of tip</b></p> <p>P : Pointed</p> <p><b>Options:</b></p> <p>C : Crown</p>	<p><b>Nbr of contacts</b></p> <p>Depends on ballcount of chip</p>	<p><b>Contact type</b></p> <p>30 : Standard SMT – Dimension A = 1.20 mm</p>	<p><b>Plating</b></p> <p>95 : Tin / Gold</p> <p>Other on request</p>	<p><b>Option code</b> (see page 16-19)</p> <p>D : Dead bug</p> <p>M : Multi frames</p> <p>U : Multi packages</p> <p>C : Converter plate</p> <p>S : Custom opening slot</p> <p>L : Locating pegs</p> <p>H : Heatsink</p> <p>F : Fan + Heatsink</p> <p>P : Thermal drain pad</p> <p>W : Transparent lid</p> <p>I : Steel retention lid</p> <p>B : Aluminium retention lid</p> <p>G : Handling button</p>
<p><b>Retention frame type (Lid)</b> (see page 12-15)</p> <p>W : TwistLock</p> <p>F : FastLock</p> <p>B : SpringLock</p> <p>H : Open Clamshell Alu (&lt;200 contacts)</p> <p>J : Clamshell Alu (&gt;200 contacts)</p> <p>L : Open Lever Clamshell Alu (&gt;200 contacts)</p>		<p><b>Grid code / Config. code</b></p> <p>Will be given by the factory after receipt of the chip datasheet</p>		<p>S : ScrewLock</p> <p>Q : Open QuickLock (&lt;200 contacts)</p> <p>D : QuickLock (&gt;200 contacts)</p> <p>M : Injection Molded ClamShell</p> <p>R : ReverseLock</p> <p>T : SlimLock</p>



# Raised SMT soldering Test Socket

For LGA / QFN / MLF / MLP / LCC Package

1.27 mm pitch (from 1.27 mm upwards)

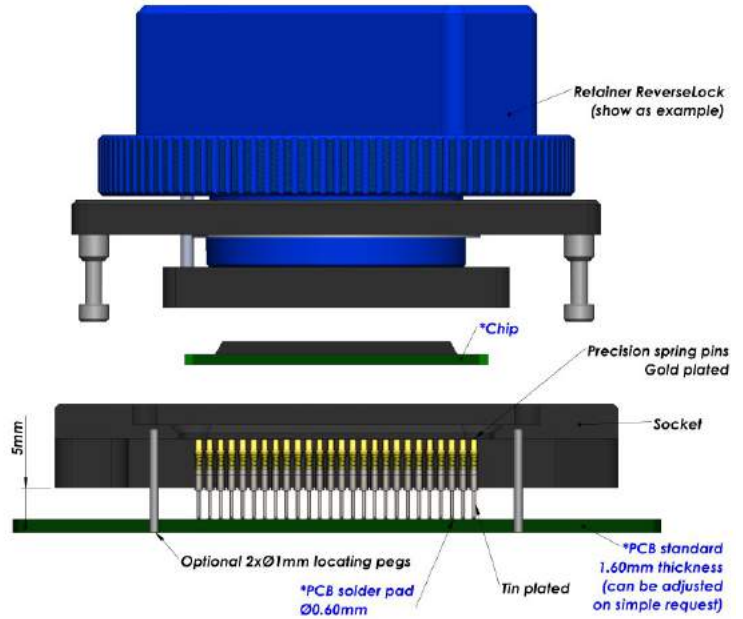
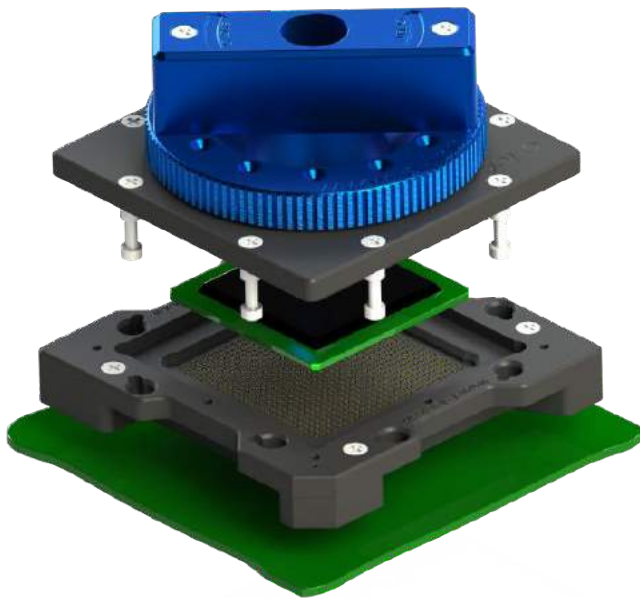
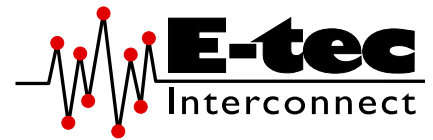

## E-tec Interconnect AG is the world leading Test socket manufacturer

The Raised SMT socket lifts the socket above close-by components on PCB and uses the same footprint as your chip. Socket is simply placed and reflowed onto the PCB in the same way as the chip and it only requires a small amount of additional board space. Raised SMT sockets are available with all retention systems. We aim to solve your requirements. Please note, we will always request the chip data to ensure we offer a compatible socket. For Raised SMT sockets in general, E-tec Interconnect AG recommends the use of locating pegs, which can be soldered to the PCB for added mechanical strength.

Specifications contact type code 1229			
Application	Surface mouting	Force	25 gr
Mounting	Raised SMT	Current rating	2.2 A
Bandwidth (GHz@-1dB)	na	Capacitance pF	na
Contact resistance	<100mOhm	Inductance nH	na
Chip contact tip shape	Single Point tip or Concave tip	Temperature range	-55°C to +150°C
PCB tip shape	Raised SMT	Mating cycles	100 K

## How to order

**LP # #### -1229 - ##### 95A #**

<p><b>Shape of tip</b></p> <p>P : Pointed</p> <p><b>Options:</b></p> <p>C : Crown</p>	<p><b>Nbr of contacts</b></p> <p>Depends on ballcount of chip</p>	<p><b>Contact type</b></p> <p>29 : Raised SMT – Dimension A = 5.00 mm</p>	<p><b>Plating</b></p> <p>95A: Tin/Gold + Alignment plate</p> <p>Other on request</p>	<p><b>Option code</b> (see page 16-19)</p> <p>D : Dead bug</p> <p>M : Multi frames</p> <p>U : Multi packages</p> <p>C : Converter plate</p> <p>S : Custom opening slot</p> <p>L : Locating pegs</p> <p>H : Heatsink</p> <p>F : Fan + Heatsink</p> <p>P : Thermal drain pad</p> <p>W : Transparent lid</p> <p>I : Steel retention lid</p> <p>B : Aluminium retention lid</p> <p>T : Torque tool fixture</p> <p>G : Handling button</p>
<p><b>Retention frame type (Lid)</b> (see page 12-15)</p> <p>W : TwistLock</p> <p>F : FastLock</p> <p>B : SpringLock</p> <p>H : Open Clamshell Alu (&lt;200 contacts)</p> <p>J : Clamshell Alu (&gt;200 contacts)</p> <p>L : Open Lever Clamshell Alu (&gt;200 contacts)</p>		<p><b>Grid code / Config. code</b></p> <p>Will be given by the factory after receipt of the chip datasheet</p>		
		<p>S : ScrewLock</p> <p>Q : Open QuickLock (&lt;200 contacts)</p> <p>D : QuickLock (&gt;200 contacts)</p> <p>M : Injection Molded ClamShell</p> <p>R : ReverseLock</p> <p>T : SlimLock</p>		



# Probe Pin Solderless Compression Test Socket

For LGA / QFN / MLF / MLP / LCC Package

1.27 mm pitch (from 1.27 mm upwards)

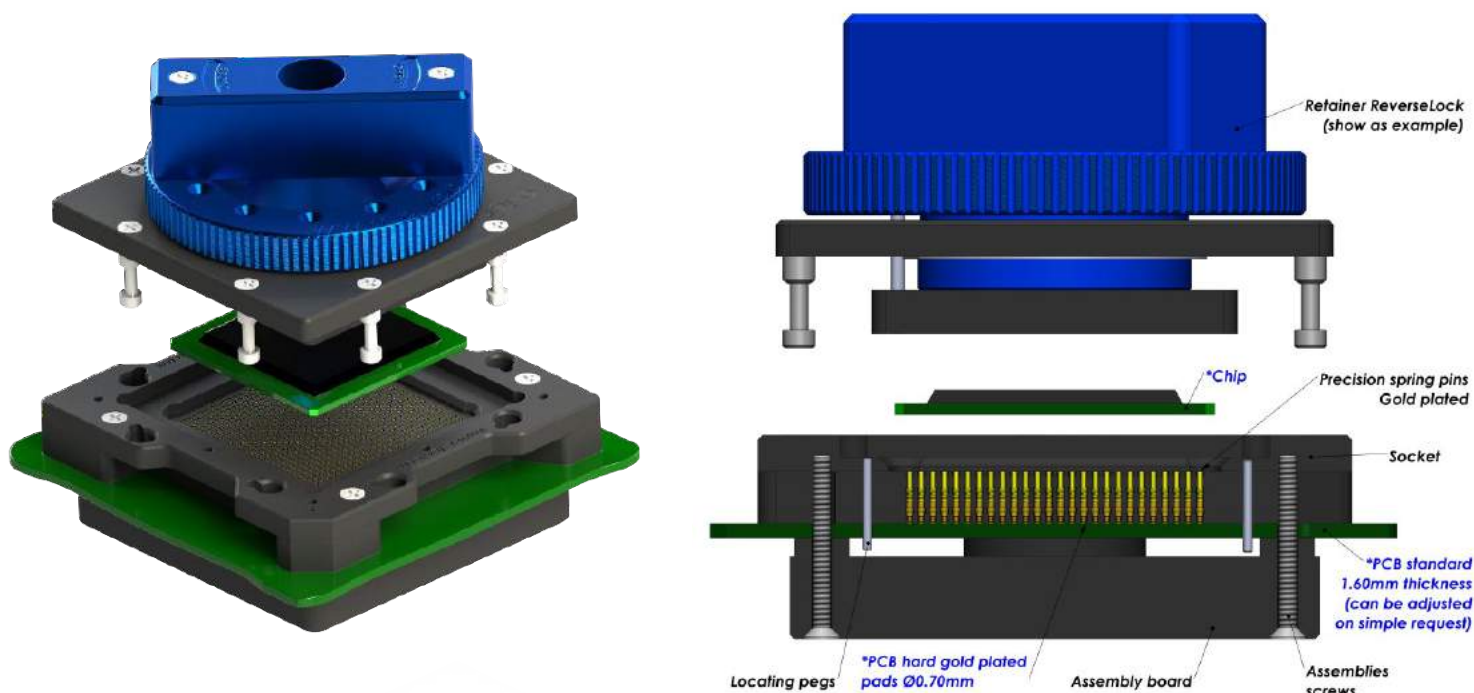
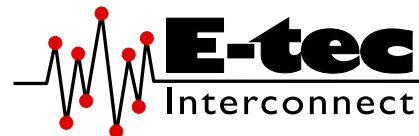

**E-tec Interconnect AG is the world leading Test socket manufacturer**

Probe Pin (Pogo) Solderless compression Test Sockets type are available for any chip size and pitch and are attached with 2, 4 or 8 screws to the PCB. The assembly board ensures perfect coplanarity of the socket. Contact reliability is guaranteed with spring loaded gold plated contacts, which are pressed onto gold plated PCB pads. Probe Pin (Pogo) Solderless compression type sockets are available with all retention systems. We aim to solve your requirements. Please note, we will always request the chip data to ensure we offer a compatible socket.

Contacts Specifications				
Contact type code	1290	1291	1294	1298
Application	Standard	High Frequency + Long Live	Frequency	Frequency
Mounting	Solderless	Solderless	Solderless	Solderless
Bandwidth (GHz@-1dB)	3 GHz	37.5 GHz	13.3 GHz	23.7 GHz
Contact resistance	<100 mOhm	45 mOhm	25 mOhm	25 mOhm
Chip contact tip shape	Single Point tip Concave tip	Crown tip	Single Point tip	Single Point tip
PCB tip shape	Single Point tip	Single Point tip	Spring	Spring
Force	25 gr	35 gr	25 gr	25 gr
Current rating	2.2 A	3 A	5 A	2.6 A
Capacitance pF	<1 pF	0.43 pF	0.76 pF	0.50 pF
Inductance nH	<2 nH	0.82 nH	1.73 nH	2.03 nH
Impedance Ohms	48 Ω	41 Ω	42.8 Ω	67.5 Ω
Temperature range	-55°C to +150°C	-40°C to +120°C	-55°C to +150°C	-55°C to +150°C
Mating cycles	100 K	300 K	100 K	100 K

More on the next page





# Probe Pin Solderless Compression Test Socket

For LGA / QFN / MLF / MLP / LCC Package

1.27 mm pitch (from 1.27 mm upwards)

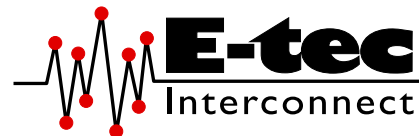

## Standard assembly boards

Small Chip size



Medium Chip size

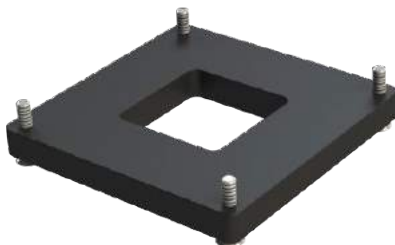

Large Chip size

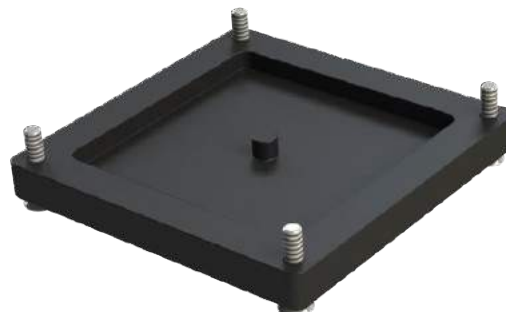

## Custom assembly boards

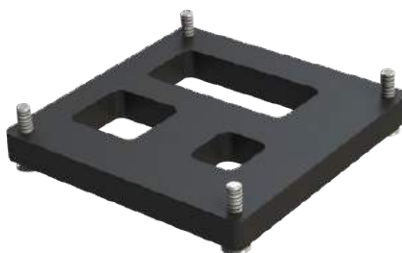
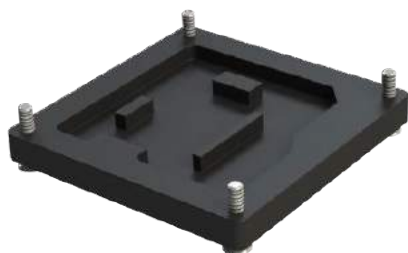

## How to order

**LP # #### -129# - ##### 55L #**

**Shape of tip**

**P** : Pointed

**Options:**

**C** : Crown

**Nbr of contacts**

Depends on ballcount of chip

**Contact type**

**91 to 98** : See "Contacts specification" chart

**90** : Standard solderless compression style

**9M**: Special mixed contact style

**Plating**

**55L**: Gold + Locating pegs

Other on request

**Option code** (see page 16-19)

**D** : Dead bug

**M** : Multi frames

**U** : Multi packages

**C** : Converter plate

**S** : Custom opening slot

**H** : Heatsink

**F** : Fan + Heatsink

**P** : Thermal drain pad

**W** : Transparent lid

**I** : Steel retention lid

**B** : Aluminium retention lid

**T** : Torque tool fixture

**G** : Handling button

**Retention frame type (Lid)** (see page 12-15)

**W**: TwistLock

**F** : FastLock

**B** : SpringLock

**H** : Open Clamshell Alu (<200 contacts)

**J** : Clamshell Alu (>200 contacts)

**L** : Open Lever Clamshell Alu (>200 contacts)

**S** : ScrewLock

**Q** : Open QuickLock (<200 contacts)

**D** : QuickLock (>200 contacts)

**M** : Injection Molded ClamShell

**R** : ReverseLock

**T** : SlimLock

**Grid code / Config. code**

Will be given by the factory after receipt of the chip datasheet



# Elastomer Solderless Compression Test Socket

For LGA / QFN / MLF / MLP / LCC Package

1.27 mm pitch (from 1.27 mm upwards)

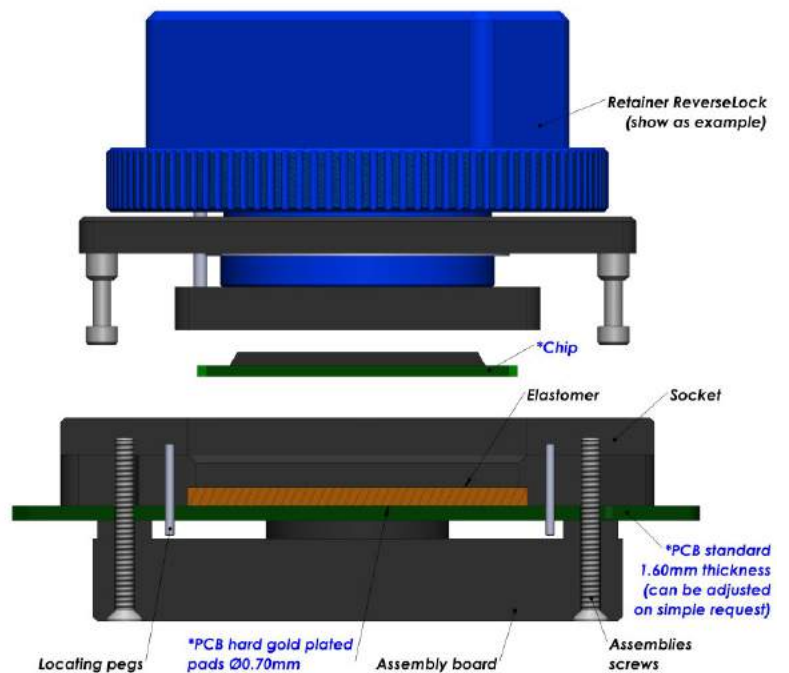
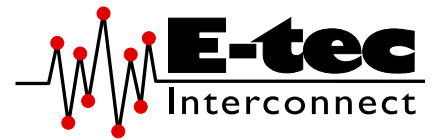

## E-tec Interconnect AG is the world leading Test socket manufacturer

The Elastomer Solderless compression Test Sockets are ideal technical solution for good signal integrity with low signal loss. The sockets are available for any chip size and pitch and are attached with 2, 4 or 8 screws to the PCB. The socket outline will be kept to a minimum and special clearances can be offered to avoid components on the PCB.

SMT and thru-hole adapter sockets are available in certain pitches (contact factory for availability first) with these elastomer interposers to allow using this high frequency interposer on PCB's which have already been laid out for SMT or thru-hole sockets. We aim to solve your requirements. Please note, we will always request the chip data to ensure we offer a compatible socket.

Contacts Specifications			
Contact type code	E1	E2	E3
Application	High Frequency		
Mounting	Solderless	Solderless	Solderless
Bandwidth (GHz@-1dB)	20 GHz	38 GHz	30 GHz
Contact resistance	30 mOhm		
Chip contact tip shape	Gold Wire		
PCB tip shape	Gold Wire		
Force	20 gr to 50 gr		
Current rating	3 A		
Capacitance pF	0.26 pF	0.12 pF	0.10 pF
Inductance nH	0.52 nH	0.35 nH	0.18 nH
Impedance Ohms	44.8 Ω	44.4 Ω	42.1 Ω
Temperature range	-40°C to +125°C		
Mating cycles	1 K		

More on the next page



# Elastomer Solderless Compression Test Socket

For LGA / QFN / MLF / MLP / LCC Package

1.27 mm pitch (from 1.27 mm upwards)

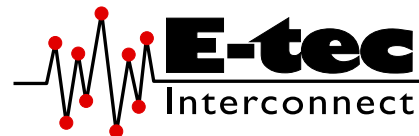

## Standard assembly boards

Small Chip size



Medium Chip size

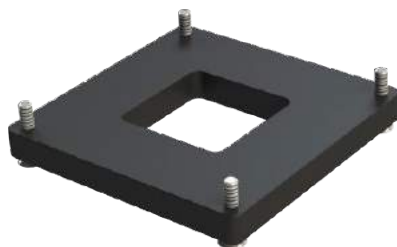

Large Chip size

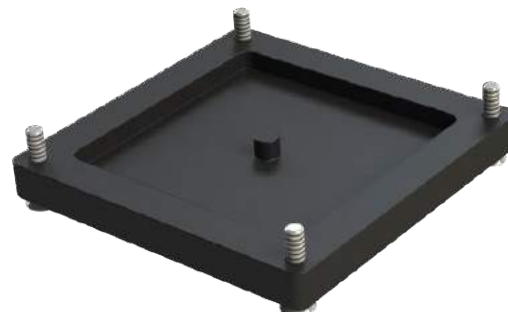

## Custom assembly boards

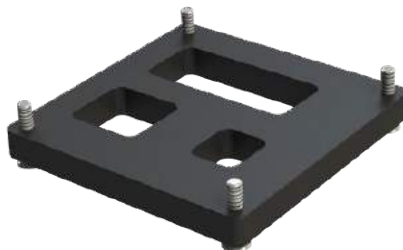
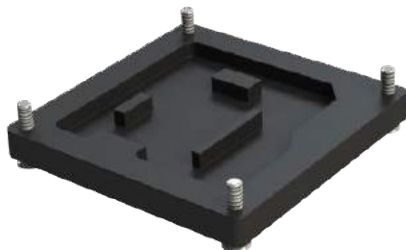

## How to order

**LE # #### -12E# - ##### 55L #**

<p><b>Shape of tip</b> E : Elastomer</p>	<p><b>Nbr of contacts</b> Depends on ballcount of chip</p>	<p><b>Contact type</b> E1 : High Frequency 20 GHz E2 : High Frequency 38 GHz E3 : High Frequency 30 GHz</p>	<p><b>Plating</b> 55L: Gold + Locating pegs</p>	<p><b>Option code</b> (see page 16-19) M : Multi frames U : Multi packages C : Converter plate S : Custom opening slot H : Heatsink F : Fan + Heatsink W : Transparent lid I : Steel retention lid B : Aluminium retention lid G : Handling button</p>
<p><b>Retention frame type (Lid)</b> (see page 12-15) W: TwistLock F : FastLock B : SpringLock H : Open Clamshell Alu (&lt;200 contacts) J : Clamshell Alu (&gt;200 contacts) L : Open Lever Clamshell Alu (&gt;200 contacts) S : ScrewLock Q : Open QuickLock (&lt;200 contacts) D : QuickLock (&gt;200 contacts) M : Injection Molded ClamShell R : ReverseLock T : SlimLock</p>		<p><b>Grid code / Config. code</b> Will be given by the factory after receipt of the chip datasheet</p>		



# Probe Pin Solderless Compression Test Socket

For CGA / PGA / PGI Package

0.30 mm pitch (from 0.30 mm to 0.39 mm)

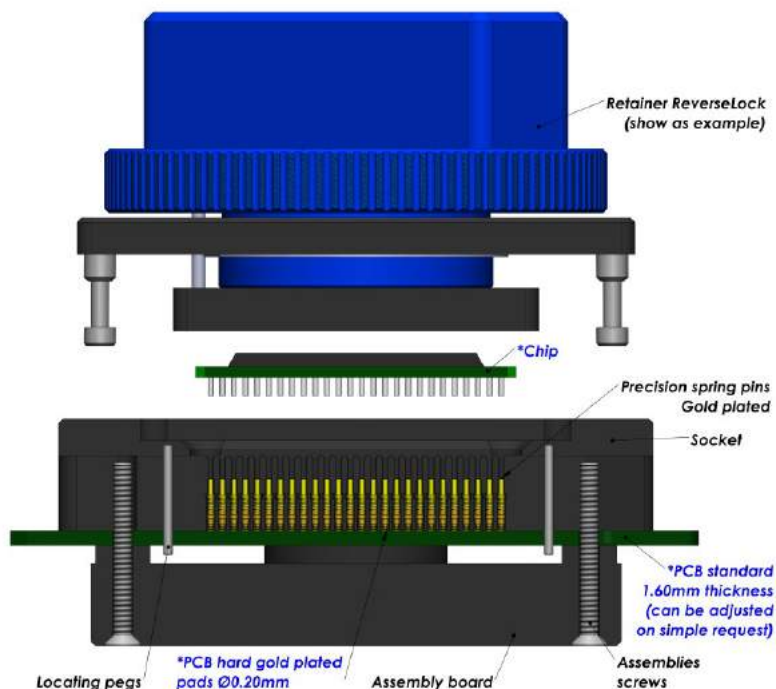
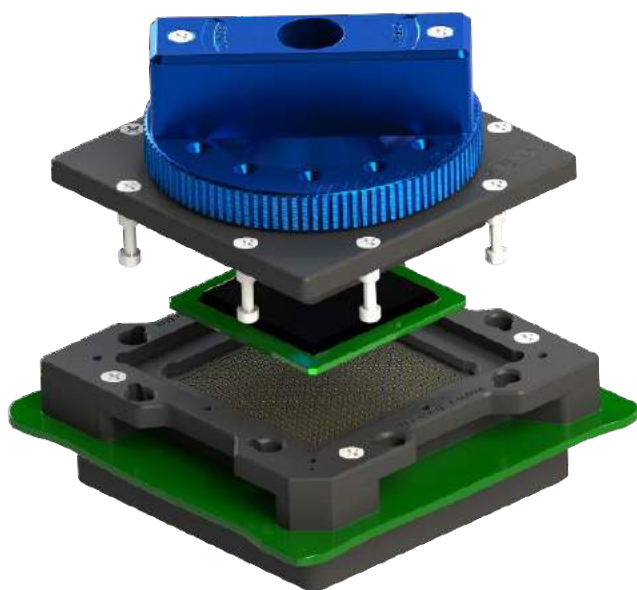
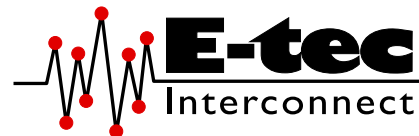

***E-tec Interconnect AG is the world leading Test socket manufacturer***

Probe Pin (Pogo) Solderless compression Test Sockets type are available for any chip size and pitch and are attached with 2, 4 or 8 screws to the PCB. The assembly board ensures perfect coplanarity of the socket. Contact reliability is guaranteed with spring loaded gold plated contacts, which are pressed onto gold plated PCB pads. Probe Pin (Pogo) Solderless compression type sockets are available with all retention systems. We aim to solve your requirements. Please note, we will always request the chip data to ensure we offer a compatible socket.

Contacts Specifications	
Contact type code	0398
Application	High Frequency
Mounting	Solderless
Bandwidth (GHz@-1dB)	19 GHz
Contact resistance	<100 mOhm
Chip contact tip shape	Single Point tip
PCB tip shape	Single Point tip
Force	17 gr
Current rating	0.8 A
Capacitance pF	0.50 pF
Inductance nH	1.27 nH
Impedance Ohms	45 Ω
Temperature range	-45°C to +125°C
Mating cycles	150 K

More on the next page



# Probe Pin Solderless Compression Test Socket

For CGA / PGA / PGI Package

0.30 mm pitch (from 0.30 mm to 0.39 mm)

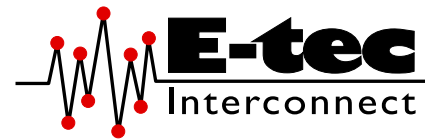

## Standard assembly boards

Small Chip size



Medium Chip size

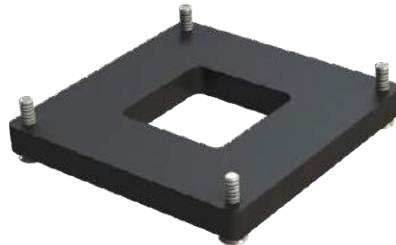

Large Chip size

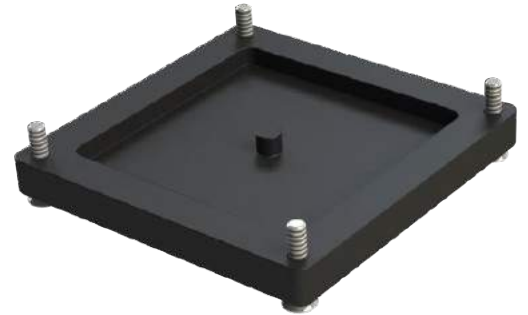

## Custom assembly boards

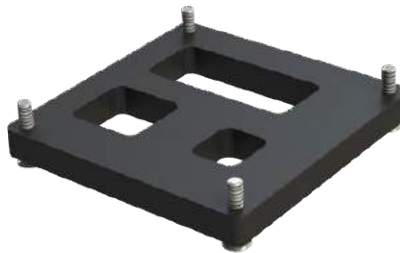
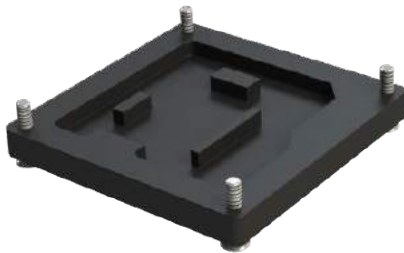

## How to order

**CP # # # # -0398 - # # # # # 55L #**

<p><b>Shape of tip</b></p> <p><b>P</b> : Pointed</p>	<p><b>Nbr of contacts</b></p> <p>Depends on ballcount of chip</p>	<p><b>Contact type</b></p> <p><b>98</b> : See "Contacts specification" chart</p>	<p><b>Plating</b></p> <p><b>55L</b>: Gold + Locating pegs Other on request</p>	<p><b>Option code</b> (see page 16-19)</p> <p><b>D</b> : Dead bug <b>M</b> : Multi frames <b>U</b> : Multi packages <b>C</b> : Converter plate <b>S</b> : Custom opening slot <b>H</b> : Heatsink <b>F</b> : Fan + Heatsink <b>P</b> : Thermal drain pad <b>W</b> : Transparent lid <b>I</b> : Steel retention lid <b>B</b> : Aluminium retention lid <b>T</b> : Torque tool fixture <b>G</b> : Handling button</p>
<p><b>Retention frame type (Lid)</b> (see page 12-15)</p> <p><b>W</b>: TwistLock <b>F</b> : FastLock <b>B</b> : SpringLock <b>H</b> : Open Clamshell Alu (&lt;200 contacts) <b>J</b> : Clamshell Alu (&gt;200 contacts) <b>L</b> : Open Lever Clamshell Alu (&gt;200 contacts)</p>		<p><b>S</b> : ScrewLock <b>Q</b> : Open QuickLock (&lt;200 contacts) <b>D</b> : QuickLock (&gt;200 contacts) <b>M</b> : Injection Molded ClamShell <b>R</b> : ReverseLock <b>T</b> : SlimLock</p>		<p><b>Grid code / Config. code</b></p> <p>Will be given by the factory after receipt of the chip datasheet</p>





# Probe Pin Solderless Compression Test Socket

For CGA / PGA / PGI Package

0.40 mm pitch (from 0.40 mm to 0.49 mm)

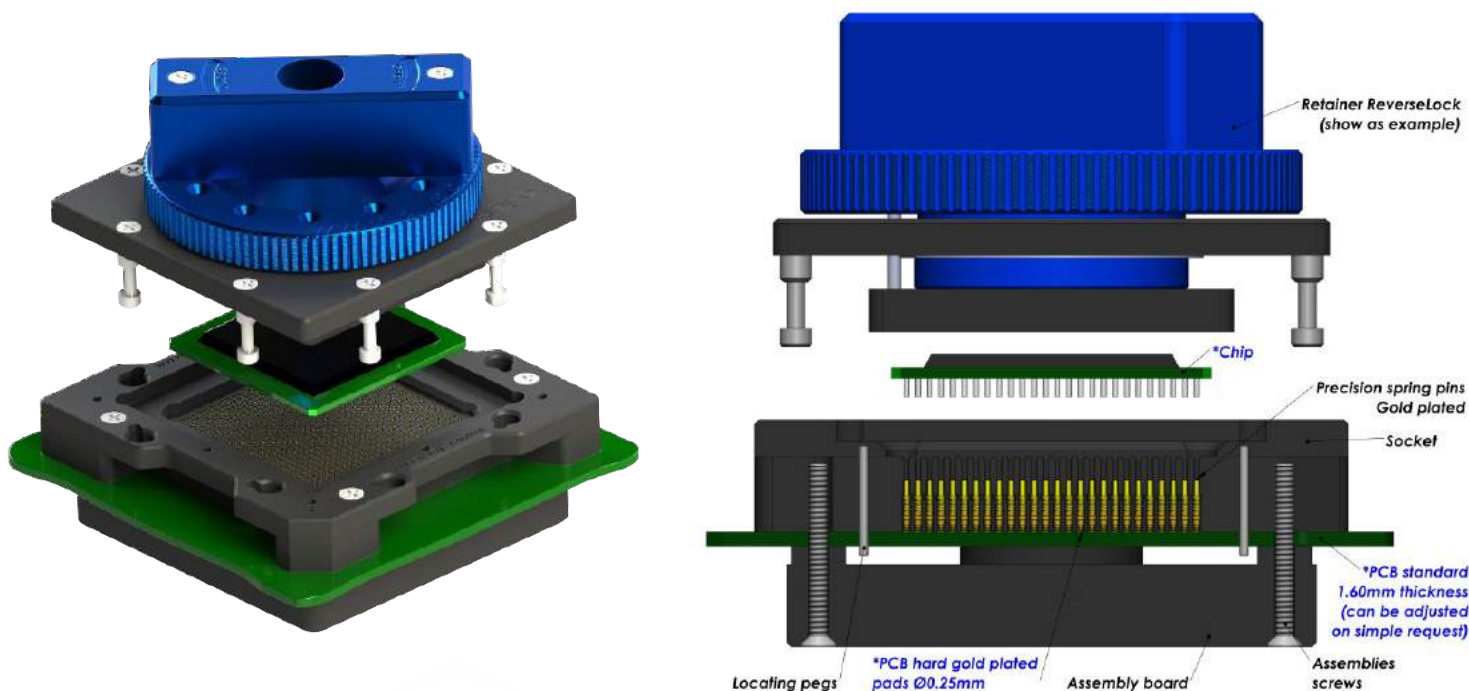
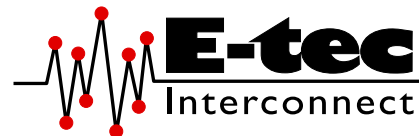

***E-tec Interconnect AG is the world leading Test socket manufacturer***

Probe Pin (Pogo) Solderless compression Test Sockets type are available for any chip size and pitch and are attached with 2, 4 or 8 screws to the PCB. The assembly board ensures perfect coplanarity of the socket. Contact reliability is guaranteed with spring loaded gold plated contacts, which are pressed onto gold plated PCB pads. Probe Pin (Pogo) Solderless compression type sockets are available with all retention systems. We aim to solve your requirements. Please note, we will always request the chip data to ensure we offer a compatible socket.

Contacts Specifications				
Contact type code	0490	0491	0492	0494
Application	Standard	Frequency	High Frequency	High Power
Mounting	Solderless	Solderless	Solderless	Solderless
Bandwidth (GHz@-1dB)	3 GHz	10 GHz	20 GHz	na
Contact resistance	<100 mOhm	100 mOhm	100 mOhm	100 mOhm
Chip contact tip shape	Single Point tip	Single Point tip	Single Point tip	Crown tip
PCB tip shape	Spring	Single Point tip	Single Point tip	Single Point tip
Force	20 gr	20 gr	20 gr	30 gr
Current rating	0.5 A	1.5 A	1.5 A	3 A
Capacitance pF	<1pF	0.90 pF	0.50 pF	na
Inductance nH	<2nH	1.50 nH	1.20 nH	na
Impedance Ohms	45 Ω	48 Ω	42 Ω	na
Temperature range	-55°C to +150°C	-40°C to +120°C	-40°C to +120°C	-40°C to +120°C
Mating cycles	100 K	300 K	100 K	100 K

**More on the next page**



# Probe Pin Solderless Compression Test Socket

For CGA / PGA / PGI Package

0.40 mm pitch (from 0.40 mm to 0.49 mm)

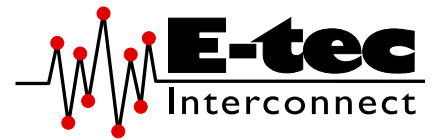

## Standard assembly boards

Small Chip size



Medium Chip size

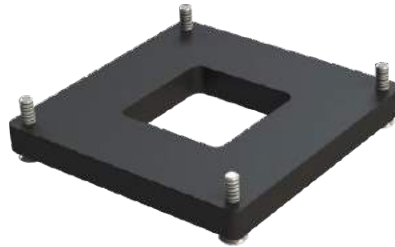

Large Chip size



## Custom assembly boards

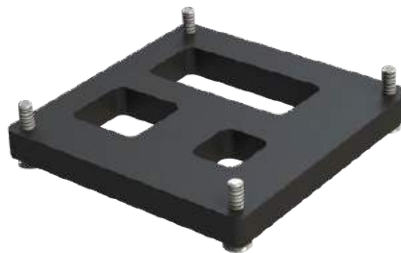
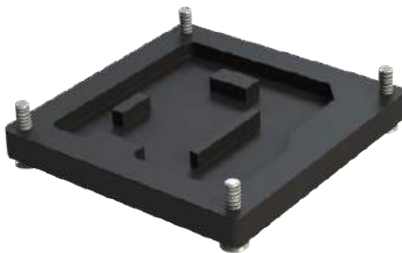

## How to order

**CP # # # # # -049# - # # # # # # 55L #**

<p><b>Shape of tip</b></p> <p>P : Pointed</p>	<p><b>Nbr of contacts</b></p> <p>Depends on ballcount of chip</p>	<p><b>Contact type</b></p> <p>91 to 94 : See "Contacts specification" chart</p> <p>90 : Standard solderless compression style</p> <p>9M: Special mixed contact style</p>	<p><b>Plating</b></p> <p>55L: Gold + Locating pegs</p> <p>Other on request</p>	<p><b>Option code</b> (see page 16-19)</p> <p>D : Dead bug</p> <p>M : Multi frames</p> <p>U : Multi packages</p> <p>C : Converter plate</p> <p>S : Custom opening slot</p> <p>H : Heatsink</p> <p>F : Fan + Heatsink</p> <p>P : Thermal drain pad</p> <p>W : Transparent lid</p> <p>I : Steel retention lid</p> <p>B : Aluminium retention lid</p> <p>T : Torque tool fixture</p> <p>G : Handling button</p>
<p><b>Retention frame type (Lid)</b> (see page 12-15)</p> <p>W: TwistLock</p> <p>F : FastLock</p> <p>B : SpringLock</p> <p>H : Open Clamshell Alu (&lt;200 contacts)</p> <p>J : Clamshell Alu (&gt;200 contacts)</p> <p>L : Open Lever Clamshell Alu (&gt;200 contacts)</p> <p>S : ScrewLock</p> <p>Q : Open QuickLock (&lt;200 contacts)</p> <p>D : QuickLock (&gt;200 contacts)</p> <p>M : Injection Molded ClamShell</p> <p>R : ReverseLock</p> <p>T : SlimLock</p>		<p><b>Grid code / Config. code</b></p> <p>Will be given by the factory after receipt of the chip datasheet</p>		





# Through-hole (THT) soldering Test Socket

For CGA / PGA / PGI Package

0.50 mm pitch (from 0.50 mm up to 0.79 mm)

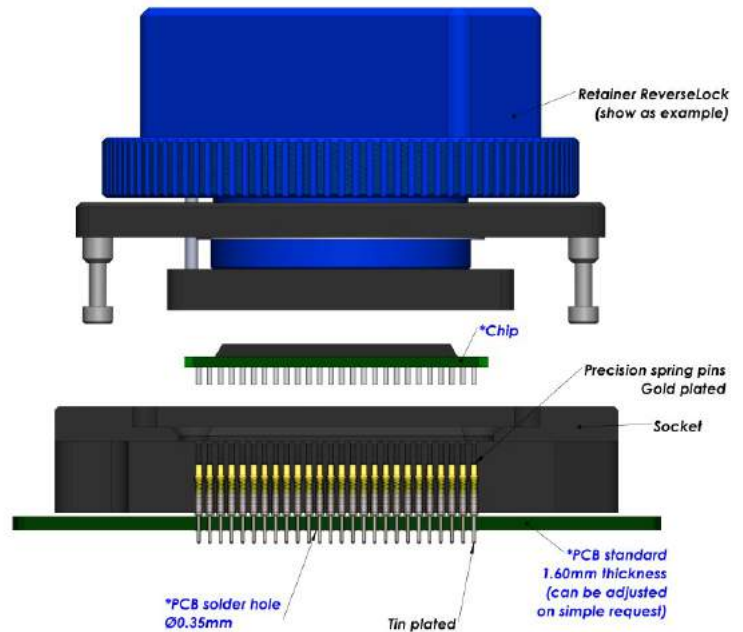
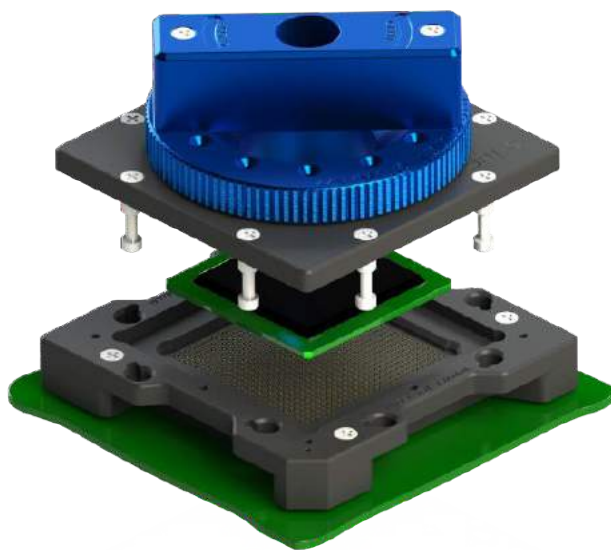

**E-tec Interconnect AG is the world leading Test socket manufacturer**

The Through-hole socket uses the same footprint as your chip. Socket is simply placed and wave soldered onto the PCB in the same way as the chip and it only requires a small amount of additional board space. Through-hole sockets are available with all retention systems. Please note, we will always request the chip data to ensure we offer a compatible socket.

Specifications contact type code 0570			
Application	Through-hole technology	Force	30 gr
Mounting	THT	Current rating	1 A
Bandwidth (GHz@-1dB)	2.7 GHz	Capacitance pF	< 1 pF
Contact resistance	<100mOhm	Inductance nH	< 2 nH
Chip contact tip shape	Single Point tip or Concave tip	Temperature range	-55°C to +150°C
PCB tip shape	Through-hole	Mating cycles	100 K

## How to order

**CU # #### -0570 - ##### 95 #**

<p><b>Shape of tip</b></p> <p>U : Concave</p> <p><b>Options:</b></p> <p>P : Pointed</p>	<p><b>Nbr of contacts</b></p> <p>Depends on ballcount of chip</p>	<p><b>Contact type</b></p> <p>70 : Standard THT</p>	<p><b>Plating</b></p> <p>95: Tin / Gold</p> <p>Other on request</p>	<p><b>Option code</b> (see page 16-19)</p> <p>D : Dead bug</p> <p>M : Multi frames</p> <p>U : Multi packages</p> <p>C : Converter plate</p> <p>S : Custom opening slot</p> <p>L : Locating pegs</p> <p>A : Alignment plate</p> <p>H : Heatsink</p> <p>F : Fan + Heatsink</p> <p>P : Thermal drain pad</p> <p>W : Transparent lid</p> <p>I : Steel retention lid</p> <p>B : Aluminium retention lid</p> <p>T : Torque tool fixture</p> <p>G : Handling button</p>
<p><b>Retention frame type (Lid)</b> (see page 12-15)</p> <p>W: TwistLock</p> <p>F: FastLock</p> <p>B: SpringLock</p> <p>H: Open Clamshell Alu (&lt;200 contacts)</p> <p>J: Clamshell Alu (&gt;200 contacts)</p> <p>L: Open Lever Clamshell Alu (&gt;200 contacts)</p>		<p><b>Grid code / Config. code</b></p> <p>Will be given by the factory after receipt of the chip datasheet</p>		
		<p>S : ScrewLock</p> <p>Q : Open QuickLock (&lt;200 contacts)</p> <p>D : QuickLock (&gt;200 contacts)</p> <p>M : Injection Molded ClamShell</p> <p>R : ReverseLock</p> <p>T : SlimLock</p>		

# Standard SMT soldering Test Socket

For CGA / PGA / PGI Package

0.50 mm pitch (from 0.50 mm up to 0.79 mm)

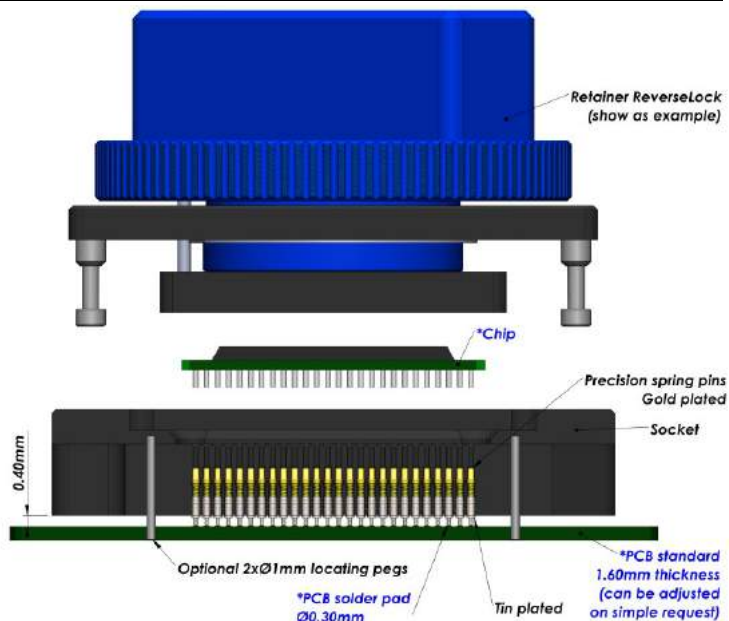
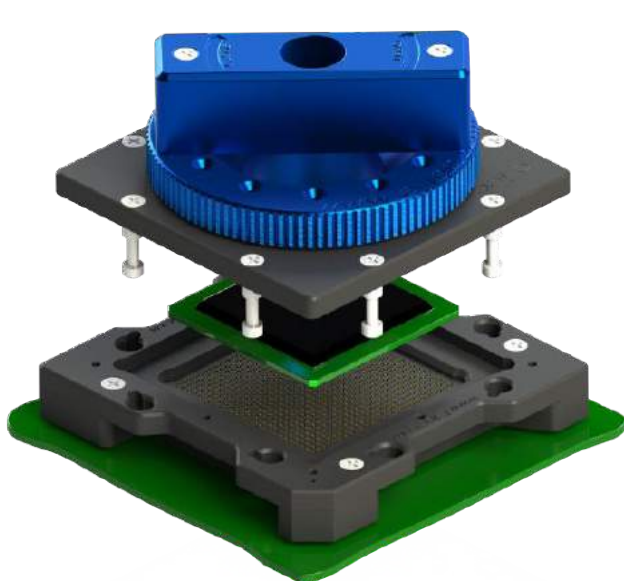
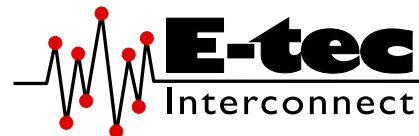

**E-tec Interconnect AG is the world leading Test socket manufacturer**

The SMT socket uses the same footprint as your chip. Socket is simply placed and reflowed onto the PCB in the same way as the chip and it only requires a small amount of additional board space. SMT type sockets are available with all retention systems. We aim to solve your requirements. Please note, we will always request the chip data to ensure we offer a compatible socket. For SMT sockets in general, E-tec Interconnect AG recommends the use of locating pegs, which can be soldered to the PCB for added mechanical strength.

Specifications contact type code 0530			
Application	Surface mouting	Force	30 gr
Mounting	SMT	Current rating	1 A
Bandwidth (GHz@-1dB)	2.7 GHz	Capacitance pF	< 1 pF
Contact resistance	<100mOhm	Inductance nH	< 2 nH
Chip contact tip shape	Single Point tip or Concave tip	Temperature range	-55°C to +150°C
PCB tip shape	SMT	Mating cycles	100 K

## How to order

**CU # #### -0530 - ##### 95 #**

### Shape of tip

U : Concave

#### Options:

P : Pointed

### Nbr of contacts

Depends on ballcount of chip

### Contact type

30 : Standard SMT – Dimension A = 0.40 mm

### Plating

95 : Tin / Gold

Other on request

### Option code (see page 16-19)

D : Dead bug

M : Multi frames

U : Multi packages

C : Converter plate

S : Custom opening slot

L : Locating pegs

H : Heatsink

F : Fan + Heatsink

P : Thermal drain pad

W : Transparent lid

I : Steel retention lid

B : Aluminium retention lid

G : Handling button

### Retention frame type (Lid) (see page 12-15)

W : TwistLock

F : FastLock

B : SpringLock

H : Open Clamshell Alu (<200 contacts)

J : Clamshell Alu (>200 contacts)

L : Open Lever Clamshell Alu (>200 contacts)

S : ScrewLock

Q : Open QuickLock (<200 contacts)

D : QuickLock (>200 contacts)

M : Injection Molded ClamShell

R : ReverseLock

T : SlimLock

### Grid code / Config. code

Will be given by the factory after receipt of the chip datasheet





# Raised SMT soldering Test Socket

For CGA / PGA / PGI Package

0.50 mm pitch (from 0.50 mm up to 0.79 mm)

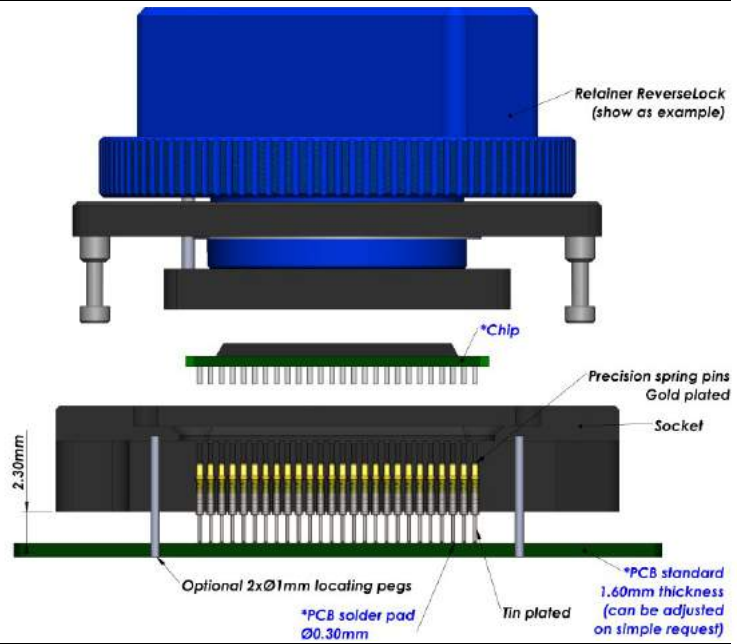
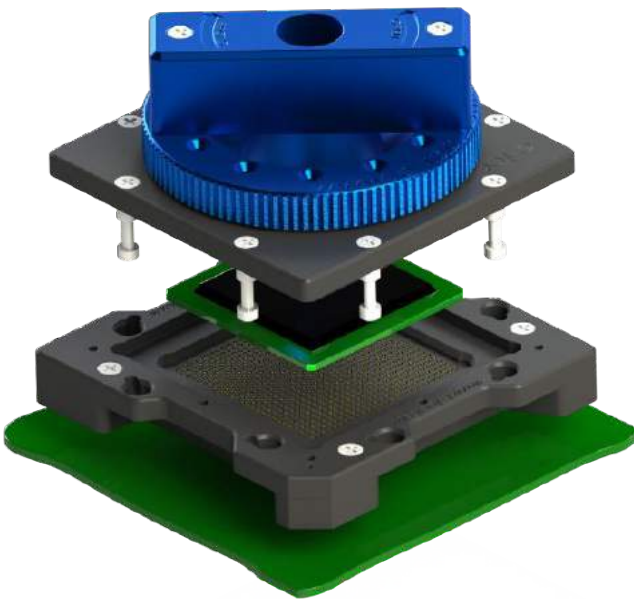
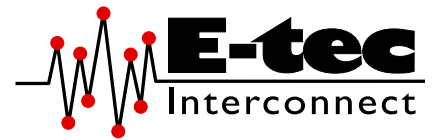

**E-tec Interconnect AG is the world leading Test socket manufacturer**

The Raised SMT socket lifts the socket above close-by components on PCB and uses the same footprint as your chip. Socket is simply placed and reflowed onto the PCB in the same way as the chip and it only requires a small amount of additional board space. Raised SMT sockets are available with all retention systems. We aim to solve your requirements. Please note, we will always request the chip data to ensure we offer a compatible socket. For Raised SMT sockets in general, E-tec Interconnect AG recommends the use of locating pegs, which can be soldered to the PCB for added mechanical strength.

Specifications contact type code 0529			
Application	Surface mouting	Force	30 gr
Mounting	Raised SMT	Current rating	1 A
Bandwidth (GHz@-1dB)	na	Capacitance pF	na
Contact resistance	<100mOhm	Inductance nH	na
Chip contact tip shape	Single Point tip or Concave tip	Temperature range	-55°C to +150°C
PCB tip shape	Raised SMT	Mating cycles	100 K

## How to order

**CU # #### -0529 - ##### 95A #**

<p><b>Shape of tip</b></p> <p>U : Concave</p> <p><b>Options:</b></p> <p>P : Pointed</p>	<p><b>Nbr of contacts</b></p> <p>Depends on ballcount of chip</p>	<p><b>Contact type</b></p> <p>29 : Raised SMT – Dimension A = 2.30 mm</p>	<p><b>Plating</b></p> <p>95A: Tin/Gold + Alignment plate</p> <p>Other on request</p>	<p><b>Option code</b> (see page 16-19)</p> <p>D : Dead bug</p> <p>M : Multi frames</p> <p>U : Multi packages</p> <p>C : Converter plate</p> <p>S : Custom opening slot</p> <p>L : Locating pegs</p> <p>H : Heatsink</p> <p>F : Fan + Heatsink</p> <p>P : Thermal drain pad</p> <p>W : Transparent lid</p> <p>I : Steel retention lid</p> <p>B : Aluminium retention lid</p> <p>T : Torque tool fixture</p> <p>G : Handling button</p>
<p><b>Retention frame type (Lid)</b> (see page 12-15)</p> <p>W : TwistLock</p> <p>F : FastLock</p> <p>B : SpringLock</p> <p>H : Open Clamshell Alu (&lt;200 contacts)</p> <p>J : Clamshell Alu (&gt;200 contacts)</p> <p>L : Open Lever Clamshell Alu (&gt;200 contacts)</p>		<p>S : ScrewLock</p> <p>Q : Open QuickLock (&lt;200 contacts)</p> <p>D : QuickLock (&gt;200 contacts)</p> <p>M : Injection Molded ClamShell</p> <p>R : ReverseLock</p> <p>T : SlimLock</p>	<p><b>Grid code / Config. code</b></p> <p>Will be given by the factory after receipt of the chip datasheet</p>	



# Probe Pin Solderless Compression Test Socket

For CGA / PGA / PGI Package

0.50 mm pitch (from 0.50 mm to 0.79 mm)

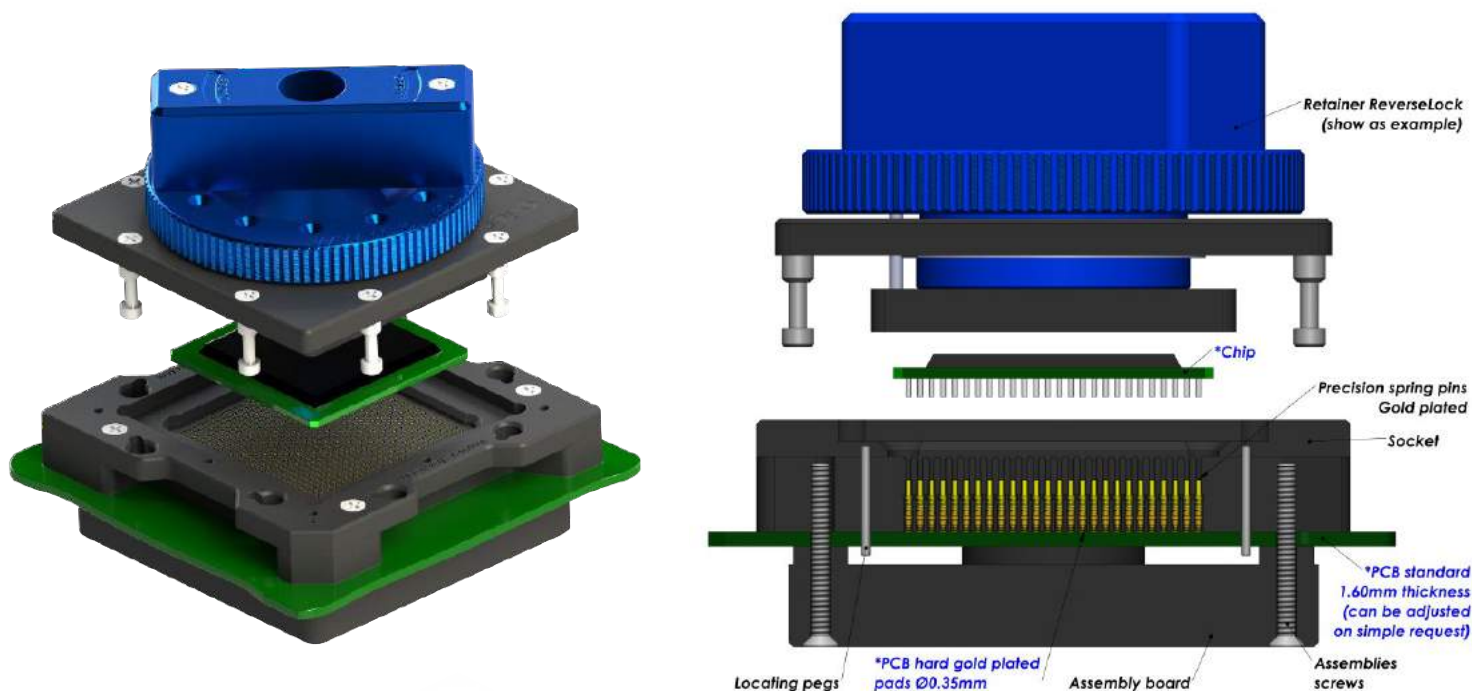
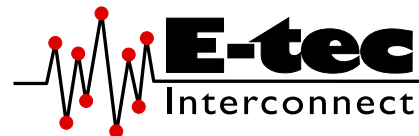

**E-tec Interconnect AG is the world leading Test socket manufacturer**

Probe Pin (Pogo) Solderless compression Test Sockets type are available for any chip size and pitch and are attached with 2, 4 or 8 screws to the PCB. The assembly board ensures perfect coplanarity of the socket. Contact reliability is guaranteed with spring loaded gold plated contacts, which are pressed onto gold plated PCB pads. Probe Pin (Pogo) Solderless compression type sockets are available with all retention systems. We aim to solve your requirements. Please note, we will always request the chip data to ensure we offer a compatible socket.

Contacts Specifications						
Contact type code	0590	0591	0592	0593	0594	0598
Application	Standard	Long live	High Frequency	High Temp & Long live	High Power	SuperHigh Frequency
Mounting	Solderless	Solderless	Solderless	Solderless	Solderless	Solderless
Bandwidth (GHz@-1dB)	3 GHz	7 GHz	29 GHz	8.9 GHz	9 GHz	40 GHz
Contact resistance	<100 mOhm	40 mOhm	100 mOhm	80 mOhm	80 mOhm	100 mOhm
Chip contact tip shape	Single Point tip Concave tip	Crown tip	Single Point tip	Crown tip	Crown tip	Single Point tip
PCB tip shape	Single Point tip	Single Point tip	Single Point tip	Single Point tip	Single Point tip	Spring
Force	30 gr	23 gr	20 gr	23 gr	30 gr	20 gr
Current rating	1.5 A	1 A	1.5 A	2 A	2 A	0.5 A
Capacitance pF	<1 pF	0.45 pF	0.48 pF	0.71 pF	na	0.36 pF
Inductance nH	<2 nH	1.08 nH	0.89 nH	0.67 nH	na	1.19 nH
Impedance Ohms	38 Ω	39 Ω	38 Ω	55 Ω	60 Ω	62 Ω
Temperature range	-55°C to +150°C	-50°C to +150°C	-40°C to +120°C	-50°C to +220°C	-50°C to +220°C	-55°C to +150°C
Mating cycles	100 K	300 K	100 K	500 K	500 K	100 K

More on the next page



# Probe Pin Solderless Compression Test Socket

For CGA / PGA / PGI Package

0.50 mm pitch (from 0.50 mm to 0.79 mm)

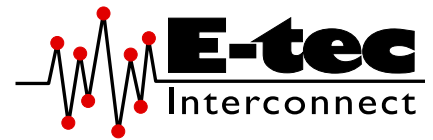

## Standard assembly boards

Small Chip size



Medium Chip size

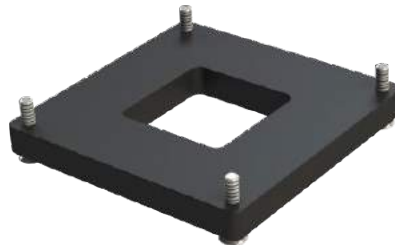

Large Chip size

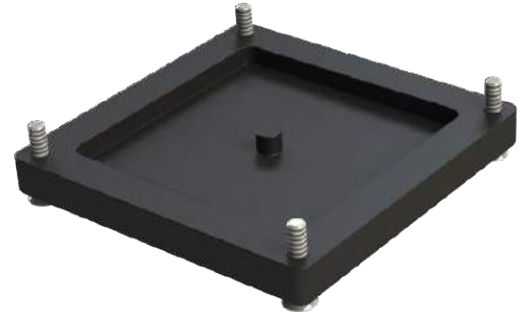

## Custom assembly boards

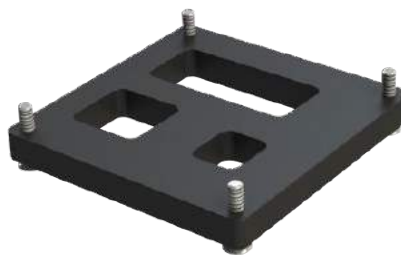
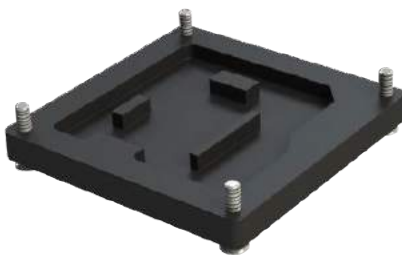

## How to order

**CU # # # # # -059# - # # # # # # 55L #**

<p><b>Shape of tip</b></p> <p>U : Concave</p> <p><b>Options:</b></p> <p>P : Pointed</p>	<p><b>Nbr of contacts</b></p> <p>Depends on ballcount of chip</p>	<p><b>Contact type</b></p> <p>91 to 98 : See "Contacts specification" chart</p> <p>90 : Standard solderless compression style</p> <p>9M: Special mixed contact style</p>	<p><b>Plating</b></p> <p>55L: Gold + Locating pegs</p> <p>Other on request</p>	<p><b>Option code</b> (see page 16-19)</p> <p>D : Dead bug</p> <p>M : Multi frames</p> <p>U : Multi packages</p> <p>C : Converter plate</p> <p>S : Custom opening slot</p> <p>H : Heatsink</p> <p>F : Fan + Heatsink</p> <p>P : Thermal drain pad</p> <p>W: Transparent lid</p> <p>I : Steel retention lid</p> <p>B : Aluminium retention lid</p> <p>T : Torque tool fixture</p> <p>G : Handling button</p>
<p><b>Retention frame type (Lid)</b> (see page 12-15)</p> <p>W: TwistLock</p> <p>F : FastLock</p> <p>B : SpringLock</p> <p>H : Open Clamshell Alu (&lt;200 contacts)</p> <p>J : Clamshell Alu (&gt;200 contacts)</p> <p>L : Open Lever Clamshell Alu (&gt;200 contacts)</p>		<p><b>Contact type</b></p> <p>S : ScrewLock</p> <p>Q : Open QuickLock (&lt;200 contacts)</p> <p>D : QuickLock (&gt;200 contacts)</p> <p>M : Injection Molded ClamShell</p> <p>R : ReverseLock</p> <p>T : SlimLock</p>		<p><b>Grid code / Config. code</b></p> <p>Will be given by the factory after receipt of the chip datasheet</p>





# Through-hole (THT) soldering Test Socket

For CGA / PGA / PGI Package

0.80 mm pitch (from 0.80 mm up to 0.99 mm)

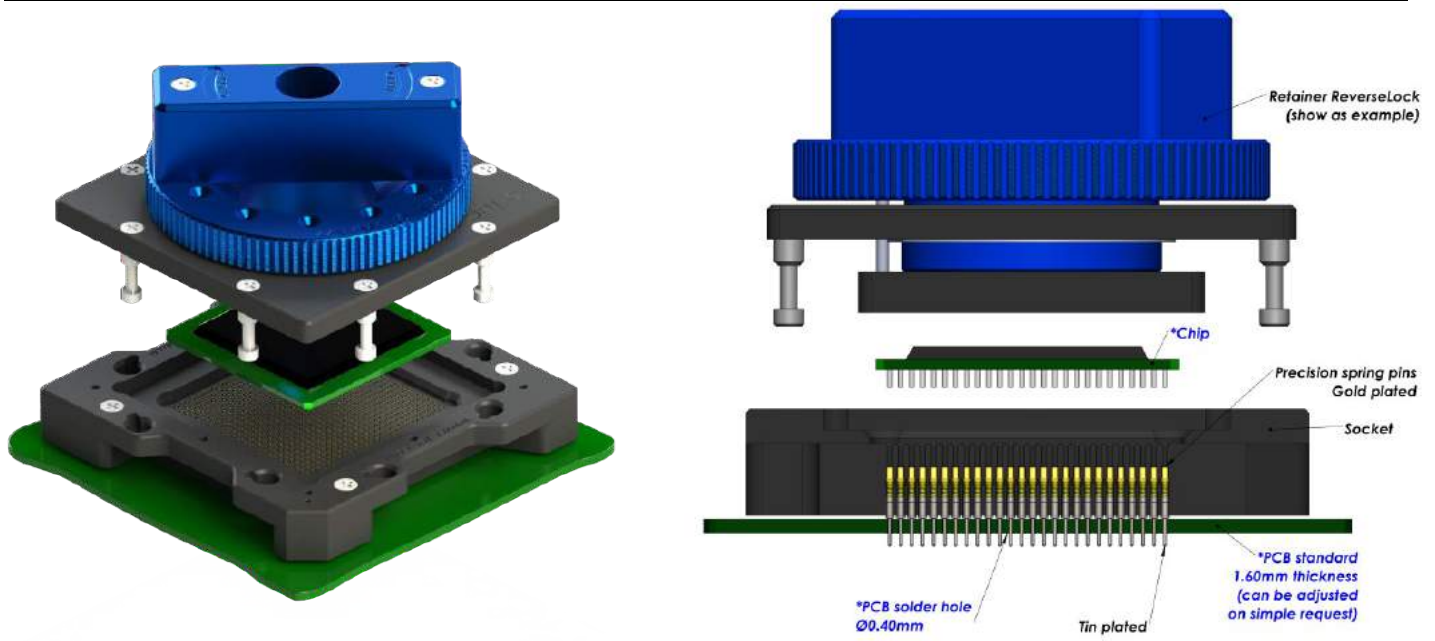

**E-tec Interconnect AG is the world leading Test socket manufacturer**

The Through-hole socket uses the same footprint as your chip. Socket is simply placed and wave soldered onto the PCB in the same way as the chip and it only requires a small amount of additional board space. Through-hole sockets are available with all retention systems. Please note, we will always request the chip data to ensure we offer a compatible socket.

Specifications contact type code 0870			
Application	Through-hole technology	Force	30 gr
Mounting	THT	Current rating	1.8 A
Bandwidth (GHz@-1dB)	3.4 GHz	Capacitance pF	0.59 pF
Contact resistance	<100mOhm	Inductance nH	1.70 nH
Chip contact tip shape	Single Point tip or Concave tip	Temperature range	-55°C to +150°C
PCB tip shape	Through-hole	Mating cycles	100 K

## How to order

**CU # #### -087# - ##### #5 #**

<p><b>Shape of tip</b></p> <p>U : Concave</p> <p><b>Options:</b></p> <p>P : Pointed</p>	<p><b>Nbr of contacts</b></p> <p>Depends on ballcount of chip</p>	<p><b>Contact type</b></p> <p>70 : Standard THT</p> <p>72 : Special THT to plug into MGS adapters</p>	<p><b>Plating</b></p> <p>95: Tin / Gold</p> <p>55: Gold / Gold</p> <p>Other on request</p>	<p><b>Option code (see page 16-19)</b></p> <p>D : Dead bug</p> <p>M : Multi frames</p> <p>U : Multi packages</p> <p>C : Converter plate</p> <p>S : Custom opening slot</p> <p>L : Locating pegs</p> <p>A : Alignment plate</p> <p>H : Heatsink</p> <p>F : Fan + Heatsink</p> <p>P : Thermal drain pad</p> <p>W : Transparent lid</p> <p>I : Steel retention lid</p> <p>B : Aluminium retention lid</p> <p>T : Torque tool fixture</p> <p>G : Handling button</p>
<p><b>Retention frame type (Lid) (see page 12-15)</b></p> <p>W: TwistLock</p> <p>F : FastLock</p> <p>B : SpringLock</p> <p>H : Open Clamshell Alu (&lt;200 contacts)</p> <p>J : Clamshell Alu (&gt;200 contacts)</p> <p>L : Open Lever Clamshell Alu (&gt;200 contacts)</p>		<p><b>Grid code / Config. code</b></p> <p>Will be given by the factory after receipt of the chip datasheet</p>		<p>S : ScrewLock</p> <p>Q : Open QuickLock (&lt;200 contacts)</p> <p>D : QuickLock (&gt;200 contacts)</p> <p>M : Injection Molded ClamShell</p> <p>R : ReverseLock</p> <p>T : SlimLock</p>



# Standard SMT soldering Test Socket

For CGA / PGA / PGI Package

0.80 mm pitch (from 0.80 mm up to 0.99 mm)

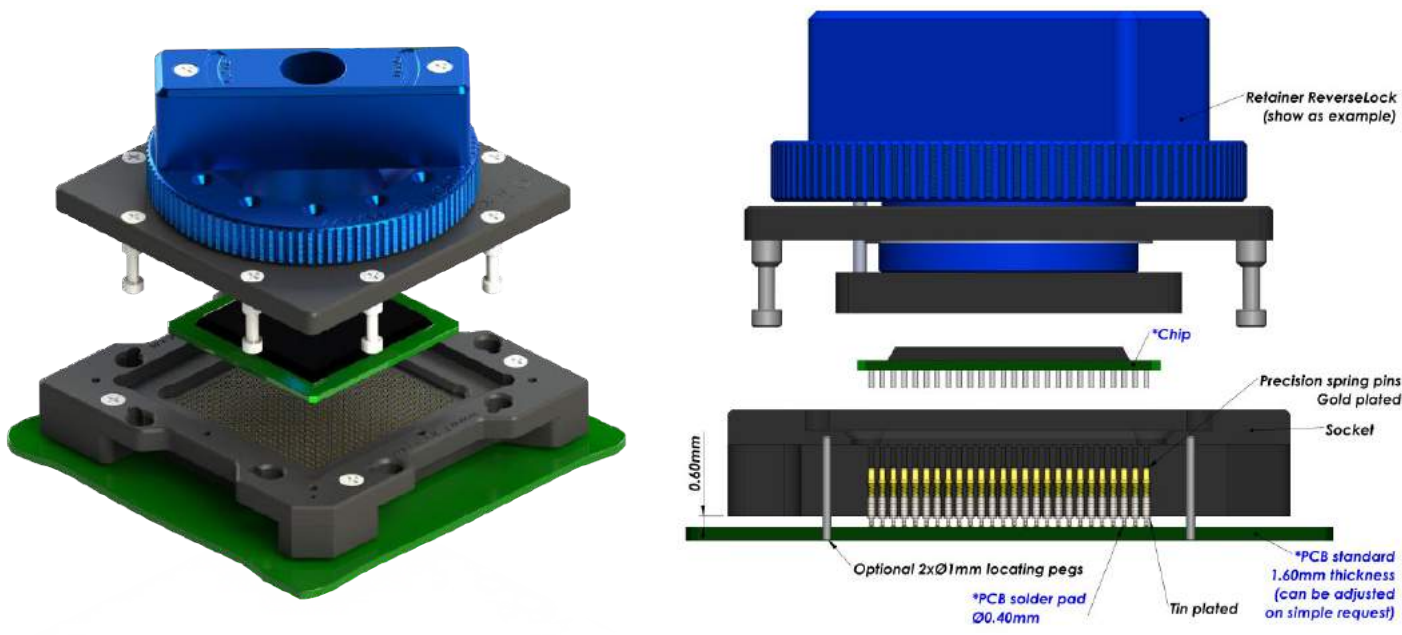
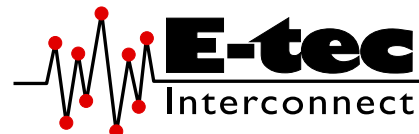

**E-tec Interconnect AG is the world leading Test socket manufacturer**

The SMT socket uses the same footprint as your chip. Socket is simply placed and reflowed onto the PCB in the same way as the chip and it only requires a small amount of additional board space. SMT type sockets are available with all retention systems. We aim to solve your requirements. Please note, we will always request the chip data to ensure we offer a compatible socket. For SMT sockets in general, E-tec Interconnect AG recommends the use of locating pegs, which can be soldered to the PCB for added mechanical strength.

Specifications contact type code 0830			
Application	Surface mouting	Force	30 gr
Mounting	SMT	Current rating	1.8 A
Bandwidth (GHz@-1dB)	2.6(4.4) GHz	Capacitance pF	0.59 pF
Contact resistance	<100mOhm	Inductance nH	1.70 nH
Chip contact tip shape	Single Point tip or Concave tip	Temperature range	-55°C to +150°C
PCB tip shape	SMT	Mating cycles	100 K

## How to order

**CU # #### -0830 - ##### 95 #**

<p><b>Shape of tip</b></p> <p>U : Concave</p> <p><b>Options:</b></p> <p>P : Pointed</p>	<p><b>Nbr of contacts</b></p> <p>Depends on ballcount of chip</p>	<p><b>Contact type</b></p> <p>30 : Standard SMT – Dimension A = 0.60 mm</p>	<p><b>Plating</b></p> <p>95 : Tin / Gold</p> <p>Other on request</p>	<p><b>Option code</b> (see page 16-19)</p> <p>D : Dead bug</p> <p>M : Multi frames</p> <p>U : Multi packages</p> <p>C : Converter plate</p> <p>S : Custom opening slot</p> <p>L : Locating pegs</p> <p>H : Heatsink</p> <p>F : Fan + Heatsink</p> <p>P : Thermal drain pad</p> <p>W : Transparent lid</p> <p>I : Steel retention lid</p> <p>B : Aluminium retention lid</p> <p>G : Handling button</p>
<p><b>Retention frame type (Lid)</b> (see page 12-15)</p> <p>W : TwistLock</p> <p>F : FastLock</p> <p>B : SpringLock</p> <p>H : Open Clamshell Alu (&lt;200 contacts)</p> <p>J : Clamshell Alu (&gt;200 contacts)</p> <p>L : Open Lever Clamshell Alu (&gt;200 contacts)</p>		<p><b>Grid code / Config. code</b></p> <p>Will be given by the factory after receipt of the chip datasheet</p>		
<p>S : ScrewLock</p> <p>Q : Open QuickLock (&lt;200 contacts)</p> <p>D : QuickLock (&gt;200 contacts)</p> <p>M : Injection Molded ClamShell</p> <p>R : ReverseLock</p> <p>T : SlimLock</p>				



# Raised SMT soldering Test Socket

For CGA / PGA / PGI Package

0.80 mm pitch (from 0.80 mm up to 0.99 mm)

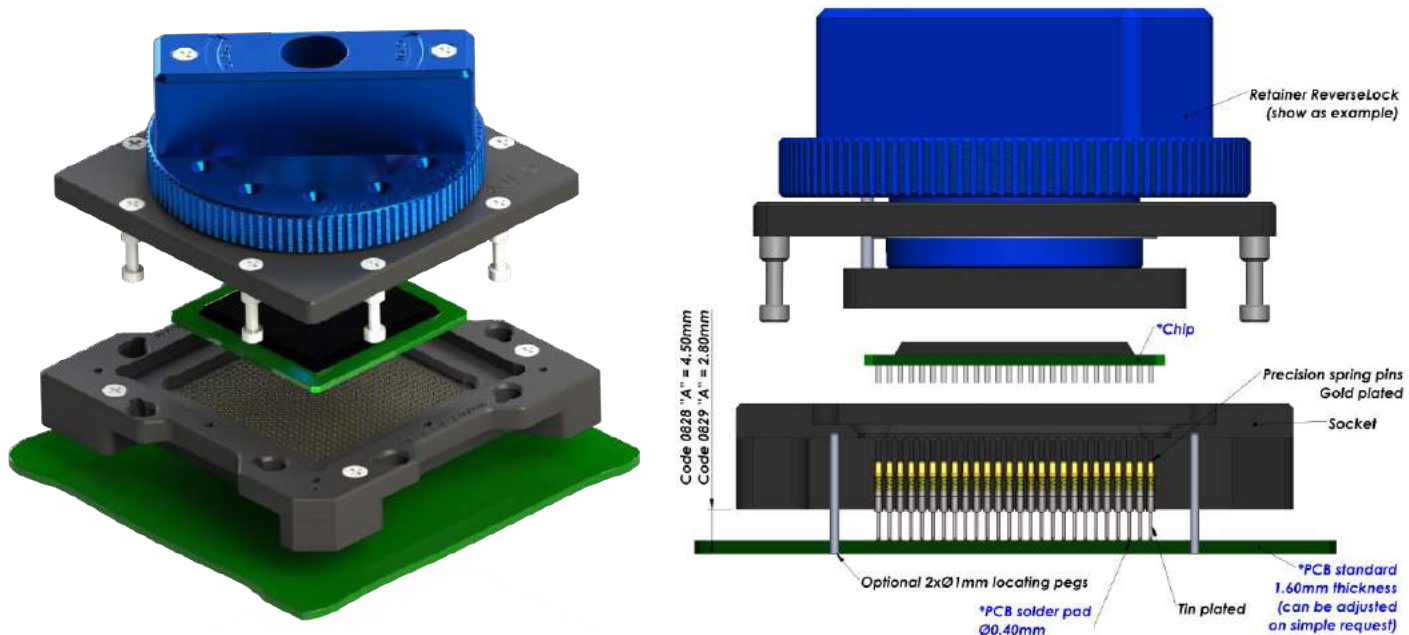

## E-tec Interconnect AG is the world leading Test socket manufacturer

The Raised SMT socket lifts the socket above close-by components on PCB and uses the same footprint as your chip. Socket is simply placed and reflowed onto the PCB in the same way as the chip and it only requires a small amount of additional board space. Raised SMT sockets are available with all retention systems. We aim to solve your requirements. Please note, we will always request the chip data to ensure we offer a compatible socket. For Raised SMT sockets in general, E-tec Interconnect AG recommends the use of locating pegs, which can be soldered to the PCB for added mechanical strength.

Specifications contact type code 0829 & 0828			
Application	Surface mouting	Force	30 gr
Mounting	Raised SMT	Current rating	1.8 A
Bandwidth (GHz@-1dB)	na	Capacitance pF	na
Contact resistance	<100mOhm	Inductance nH	na
Chip contact tip shape	Single Point tip or Concave tip	Temperature range	-55°C to +150°C
PCB tip shape	Raised SMT	Mating cycles	100 K

## How to order

# CU # #### -082# - ##### 95A #

<p><b>Shape of tip</b></p> <p>U : Concave</p> <p><b>Options:</b></p> <p>P : Pointed</p>	<p><b>Nbr of contacts</b></p> <p>Depends on ballcount of chip</p>	<p><b>Contact type</b></p> <p>29 : Raised SMT – Dimension A = 2.80 mm</p> <p>28 : Special Raised SMT - Dim. A = 4.50 mm</p>	<p><b>Plating</b></p> <p>95A: Tin/Gold + Alignment plate</p> <p>Other on request</p>	<p><b>Option code</b> (see page 16-19)</p> <p>D : Dead bug</p> <p>M : Multi frames</p> <p>U : Multi packages</p> <p>C : Converter plate</p> <p>S : Custom opening slot</p> <p>L : Locating pegs</p> <p>H : Heatsink</p> <p>F : Fan + Heatsink</p> <p>P : Thermal drain pad</p> <p>W : Transparent lid</p> <p>I : Steel retention lid</p> <p>B : Aluminium retention lid</p> <p>T : Torque tool fixture</p> <p>G : Handling button</p>
<p><b>Retention frame type (Lid)</b> (see page 12-15)</p> <p>W: TwistLock</p> <p>F : FastLock</p> <p>B : SpringLock</p> <p>H : Open Clamshell Alu (&lt;200 contacts)</p> <p>J : Clamshell Alu (&gt;200 contacts)</p> <p>L : Open Lever Clamshell Alu (&gt;200 contacts)</p>		<p>S : ScrewLock</p> <p>Q : Open QuickLock (&lt;200 contacts)</p> <p>D : QuickLock (&gt;200 contacts)</p> <p>M : Injection Molded ClamShell</p> <p>R : ReverseLock</p> <p>T : SlimLock</p>	<p><b>Grid code / Config. code</b></p> <p>Will be given by the factory after receipt of the chip datasheet</p>	

# Probe Pin Solderless Compression Test Socket

For CGA / PGA / PGI Package

0.80 mm pitch (from 0.80 mm to 0.99 mm)

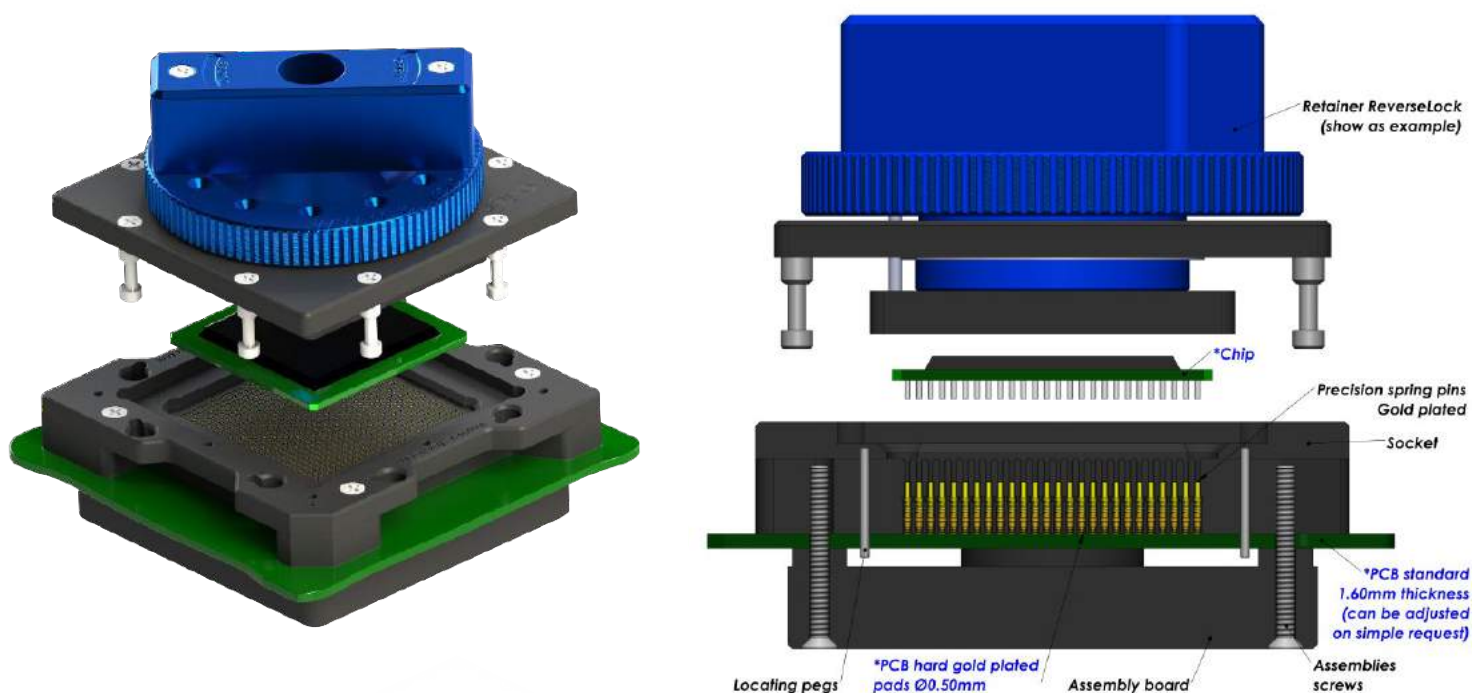
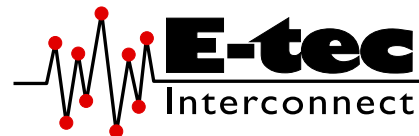

**E-tec Interconnect AG is the world leading Test socket manufacturer**

Probe Pin (Pogo) Solderless compression Test Sockets type are available for any chip size and pitch and are attached with 2, 4 or 8 screws to the PCB. The assembly board ensures perfect coplanarity of the socket. Contact reliability is guaranteed with spring loaded gold plated contacts, which are pressed onto gold plated PCB pads. Probe Pin (Pogo) Solderless compression type sockets are available with all retention systems. We aim to solve your requirements. Please note, we will always request the chip data to ensure we offer a compatible socket.

Contacts Specifications						
Contact type code	0890	0891	0893	0892	0894	0898
Application	Standard	High Frequency	Low Contact Resistance	High Frequency	Frequency	Frequency
Mounting	Solderless	Solderless	Solderless	Solderless	Solderless	Solderless
Bandwidth (GHz@-1dB)	3.4 GHz	36 GHz	7 GHz	31 GHz	14 GHz	31.7 GHz
Contact resistance	<100 mOhm	100 mOhm	40 mOhm	90 mOhm	90 mOhm	25 mOhm
Chip contact tip shape	Single Point tip Concave tip	Single Point tip	Crown tip	Single Point tip	Single Point tip	Single Point tip
PCB tip shape	Single Point tip	Single Point tip	Single Point tip	Spring	Spring	Spring
Force	30 gr	33 gr	23 gr	20 gr	20 gr	25 gr
Current rating	1.8 A	1 A	1 A	0.5 A	0.5 A	2.6 A
Capacitance pF	<1 pF	0.47 pF	0.55 pF	0.37 pF	0.30 pF	0.60 pF
Inductance nH	<2 nH	0.93 nH	1.08 nH	1.67 nH	1.66 nH	1.38 nH
Impedance Ohms	40 Ω	38 Ω	39 Ω	73 Ω	78 Ω	44.8 Ω
Temperature range	-55°C to +150°C	-40°C to +120°C	-50°C to +150°C	-55°C to +150°C	-55°C to +150°C	-55°C to +150°C
Mating cycles	100 K	100 K	100 K	100 K	100 K	100 K

More on the next page



# Probe Pin Solderless Compression Test Socket

For CGA / PGA / PGI Package

0.80 mm pitch (from 0.80 mm to 0.99 mm)

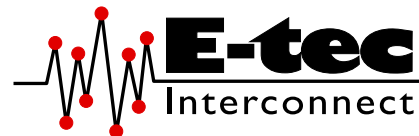

## Standard assembly boards

Small Chip size



Medium Chip size

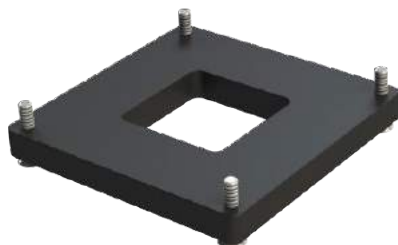

Large Chip size



## Custom assembly boards

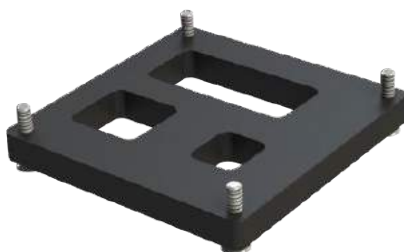
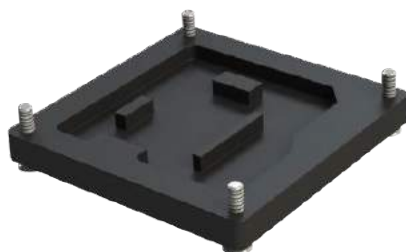

## How to order

**CU # # # # # -089# - # # # # # # 55L #**

**Shape of tip**

**U** : Concave

**Options:**

**P** : Pointed

**Nbr of contacts**

Depends on ballcount of chip

**Contact type**

**91 to 98** : See "Contacts specification" chart

**90** : Standard solderless compression style

**9M**: Special mixed contact style

**Plating**

**55L**: Gold + Locating pegs

Other on request

**Option code** (see page 16-19)

**D** : Dead bug

**M** : Multi frames

**U** : Multi packages

**C** : Converter plate

**S** : Custom opening slot

**H** : Heatsink

**F** : Fan + Heatsink

**P** : Thermal drain pad

**W** : Transparent lid

**I** : Steel retention lid

**B** : Aluminium retention lid

**T** : Torque tool fixture

**G** : Handling button

**Retention frame type (Lid)** (see page 12-15)

**W**: TwistLock

**F** : FastLock

**B** : SpringLock

**H** : Open Clamshell Alu (<200 contacts)

**J** : Clamshell Alu (>200 contacts)

**L** : Open Lever Clamshell Alu (>200 contacts)

**S** : ScrewLock

**Q** : Open QuickLock (<200 contacts)

**D** : QuickLock (>200 contacts)

**M** : Injection Molded ClamShell

**R** : ReverseLock

**T** : SlimLock

**Grid code / Config. code**

Will be given by the factory after receipt of the chip datasheet







# Through-hole (THT) soldering Test Socket

For CGA / PGA / PGI Package

1.00 mm pitch (from 1.00 mm up to 1.26 mm)

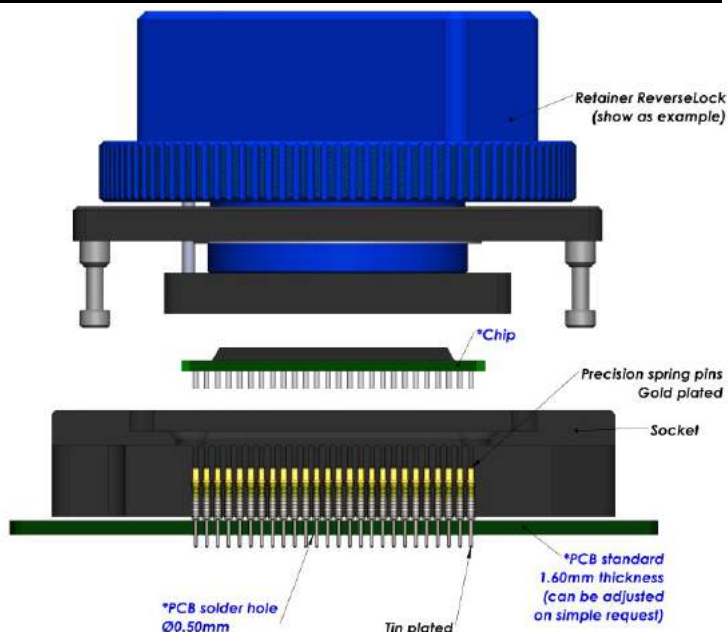
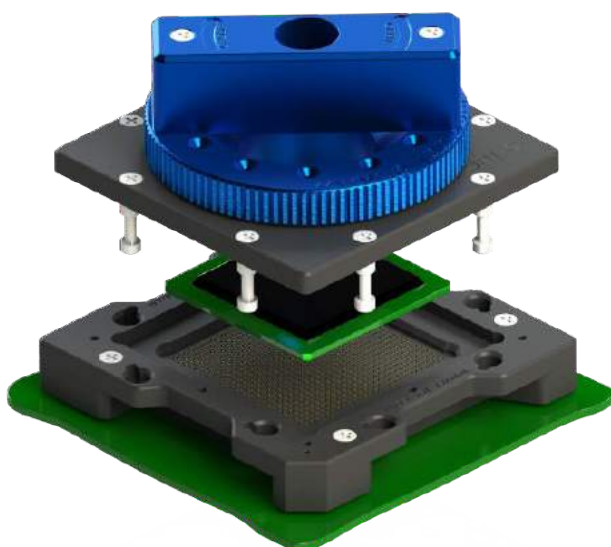
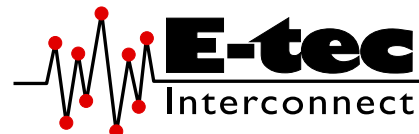

**E-tec Interconnect AG is the world leading Test socket manufacturer**

The Through-hole socket uses the same footprint as your chip. Socket is simply placed and wave soldered onto the PCB in the same way as the chip and it only requires a small amount of additional board space. Through-hole sockets are available with all retention systems. Please note, we will always request the chip data to ensure we offer a compatible socket.

Specifications contact type code 1070			
Application	Through-hole technology	Force	25 gr
Mounting	THT	Current rating	1.8 A
Bandwidth (GHz@-1dB)	3.4 GHz	Capacitance pF	1.03 pF
Contact resistance	<100mOhm	Inductance nH	1.80 nH
Chip contact tip shape	Single Point tip or Concave tip	Temperature range	-55°C to +150°C
PCB tip shape	Through-hole	Mating cycles	100 K

## How to order

**CU # #### -107# - ##### #5 #**

### Shape of tip

**U** : Concave

#### Options:

**P** : Pointed

### Nbr of contacts

Depends on ballcount of chip

### Contact type

**70** : Standard THT

**72** : Special THT to plug into MGS adapters

### Plating

**95**: Tin / Gold

**55**: Gold / Gold

Other on request

### Option code (see page 16-19)

**D** : Dead bug

**M** : Multi frames

**U** : Multi packages

**C** : Converter plate

**S** : Custom opening slot

**L** : Locating pegs

**A** : Alignment plate

**H** : Heatsink

**F** : Fan + Heatsink

**P** : Thermal drain pad

**W** : Transparent lid

**I** : Steel retention lid

**B** : Aluminium retention lid

**T** : Torque tool fixture

**G** : Handling button

### Retention frame type (Lid) (see page 12-15)

**W** : TwistLock

**F** : FastLock

**B** : SpringLock

**H** : Open Clamshell Alu (<200 contacts)

**J** : Clamshell Alu (>200 contacts)

**L** : Open Lever Clamshell Alu (>200 contacts)

**S** : ScrewLock

**Q** : Open QuickLock (<200 contacts)

**D** : QuickLock (>200 contacts)

**M** : Injection Molded ClamShell

**R** : ReverseLock

**T** : SlimLock

### Grid code / Config. code

Will be given by the factory after receipt of the chip datasheet



# Standard SMT soldering Test Socket

For CGA / PGA / PGI Package

1.00 mm pitch (from 1.00 mm up to 1.26 mm)

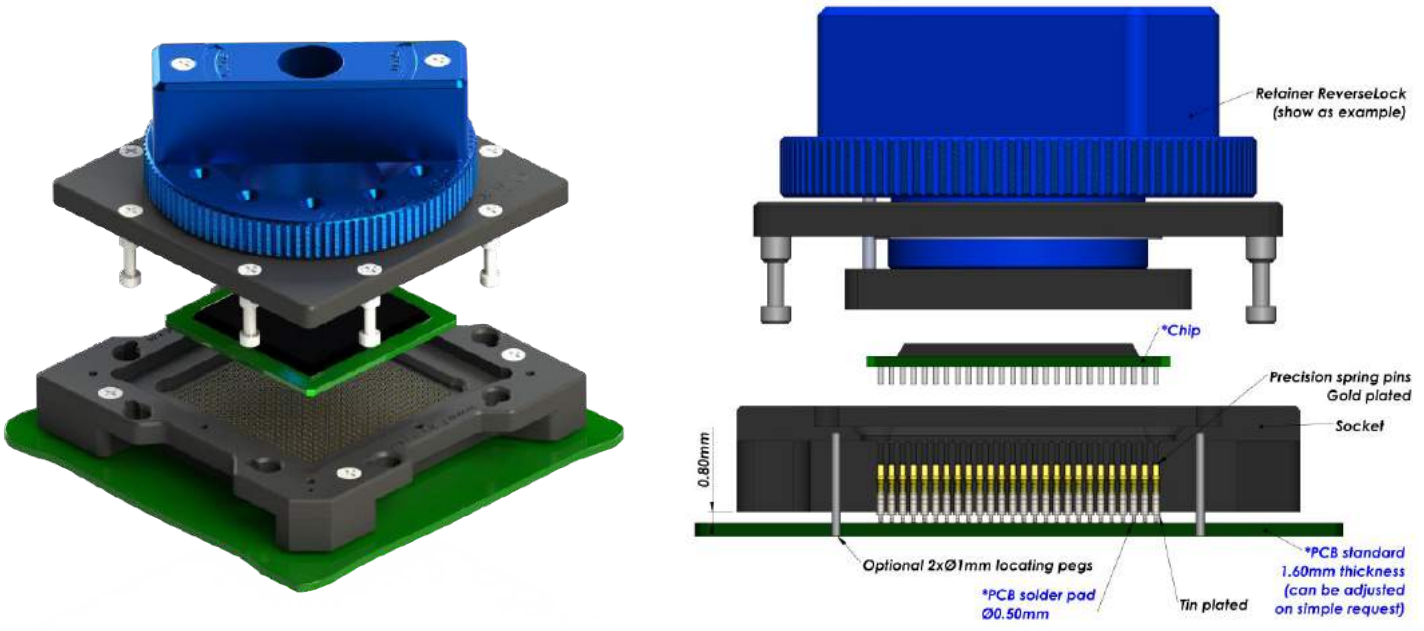
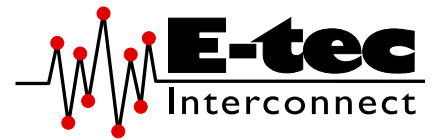

**E-tec Interconnect AG is the world leading Test socket manufacturer**

The SMT socket uses the same footprint as your chip. Socket is simply placed and reflowed onto the PCB in the same way as the chip and it only requires a small amount of additional board space. SMT type sockets are available with all retention systems. We aim to solve your requirements. Please note, we will always request the chip data to ensure we offer a compatible socket. For SMT sockets in general, E-tec Interconnect AG recommends the use of locating pegs, which can be soldered to the PCB for added mechanical strength.

Specifications contact type code 1030			
Application	Surface mouting	Force	25 gr
Mounting	SMT	Current rating	1.8 A
Bandwidth (GHz@-1dB)	2.8(6.6) GHz	Capacitance pF	0.62 pF
Contact resistance	<100mOhm	Inductance nH	1.97 nH
Chip contact tip shape	Single Point tip or Concave tip	Temperature range	-55°C to +150°C
PCB tip shape	SMT	Mating cycles	100 K

## How to order

**CU # #### -1030 - ##### 95 #**

<p><b>Shape of tip</b></p> <p>U : Concave</p> <p><b>Options:</b></p> <p>P : Pointed</p>	<p><b>Nbr of contacts</b></p> <p>Depends on ballcount of chip</p>	<p><b>Contact type</b></p> <p>30 : Standard SMT – Dimension A = 0.80 mm</p>	<p><b>Plating</b></p> <p>95 : Tin / Gold</p> <p>Other on request</p>	<p><b>Option code</b> (see page 16-19)</p> <p>D : Dead bug</p> <p>M : Multi frames</p> <p>U : Multi packages</p> <p>C : Converter plate</p> <p>S : Custom opening slot</p> <p>L : Locating pegs</p> <p>H : Heatsink</p> <p>F : Fan + Heatsink</p> <p>P : Thermal drain pad</p> <p>W : Transparent lid</p> <p>I : Steel retention lid</p> <p>B : Aluminium retention lid</p> <p>G : Handling button</p>
<p><b>Retention frame type (Lid)</b> (see page 12-15)</p> <p>W : TwistLock</p> <p>F : FastLock</p> <p>B : SpringLock</p> <p>H : Open Clamshell Alu (&lt;200 contacts)</p> <p>J : Clamshell Alu (&gt;200 contacts)</p> <p>L : Open Lever Clamshell Alu (&gt;200 contacts)</p>		<p><b>Grid code / Config. code</b></p> <p>Will be given by the factory after receipt of the chip datasheet</p>		
		<p>S : ScrewLock</p> <p>Q : Open QuickLock (&lt;200 contacts)</p> <p>D : QuickLock (&gt;200 contacts)</p> <p>M : Injection Molded ClamShell</p> <p>R : ReverseLock</p> <p>T : SlimLock</p>		



# Raised SMT soldering Test Socket

For CGA / PGA / PGI Package

1.00 mm pitch (from 1.00 mm up to 1.26 mm)

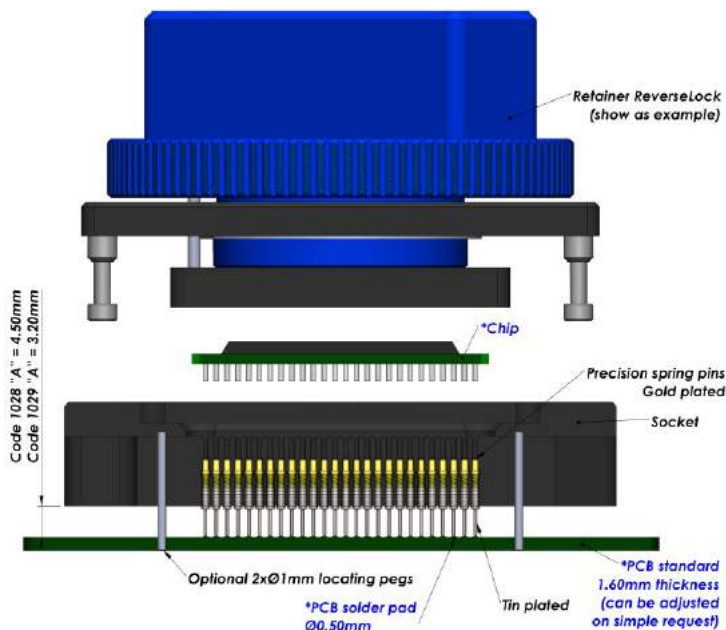
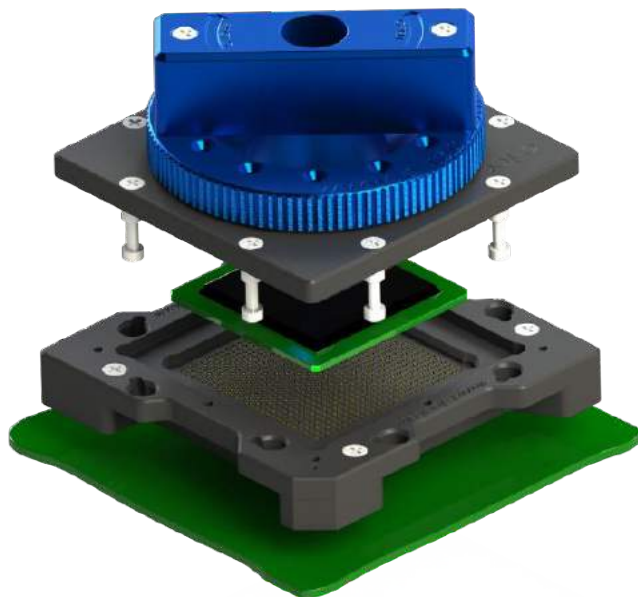
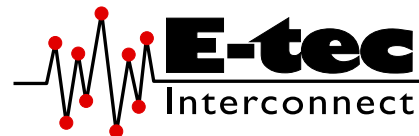

**E-tec Interconnect AG is the world leading Test socket manufacturer**

The Raised SMT socket lifts the socket above close-by components on PCB and uses the same footprint as your chip. Socket is simply placed and reflowed onto the PCB in the same way as the chip and it only requires a small amount of additional board space. Raised SMT sockets are available with all retention systems. We aim to solve your requirements. Please note, we will always request the chip data to ensure we offer a compatible socket. For Raised SMT sockets in general, E-tec Interconnect AG recommends the use of locating pegs, which can be soldered to the PCB for added mechanical strength.

Specifications contact type code 1029 & 1028			
Application	Surface mouting	Force	25 gr
Mounting	Raised SMT	Current rating	1.8 A
Bandwidth (GHz@-1dB)	na	Capacitance pF	na
Contact resistance	<100mOhm	Inductance nH	na
Chip contact tip shape	Single Point tip or Concave tip	Temperature range	-55°C to +150°C
PCB tip shape	Raised SMT	Mating cycles	100 K

## How to order

**CU # #### -102# - ##### 95A #**

<p><b>Shape of tip</b></p> <p>U : Concave</p> <p><b>Options:</b></p> <p>P : Pointed</p>	<p><b>Nbr of contacts</b></p> <p>Depends on ballcount of chip</p>	<p><b>Contact type</b></p> <p>29 : Raised SMT – Dimension A = 3.20 mm</p> <p>28 : Special Raised SMT - Dim. A = 4.50 mm</p>	<p><b>Plating</b></p> <p>95A: Tin/Gold + Alignment plate</p> <p>Other on request</p>	<p><b>Option code</b> (see page 16-19)</p> <p>D : Dead bug</p> <p>M : Multi frames</p> <p>U : Multi packages</p> <p>C : Converter plate</p> <p>S : Custom opening slot</p> <p>L : Locating pegs</p> <p>H : Heatsink</p> <p>F : Fan + Heatsink</p> <p>P : Thermal drain pad</p> <p>W : Transparent lid</p> <p>I : Steel retention lid</p> <p>B : Aluminium retention lid</p> <p>T : Torque tool fixture</p> <p>G : Handling button</p>
<p><b>Retention frame type (Lid)</b> (see page 12-15)</p> <p>W : TwistLock</p> <p>F : FastLock</p> <p>B : SpringLock</p> <p>H : Open Clamshell Alu (&lt;200 contacts)</p> <p>J : Clamshell Alu (&gt;200 contacts)</p> <p>L : Open Lever Clamshell Alu (&gt;200 contacts)</p>		<p>S : ScrewLock</p> <p>Q : Open QuickLock (&lt;200 contacts)</p> <p>D : QuickLock (&gt;200 contacts)</p> <p>M : Injection Molded ClamShell</p> <p>R : ReverseLock</p> <p>T : SlimLock</p>		<p><b>Grid code / Config. code</b></p> <p>Will be given by the factory after receipt of the chip datasheet</p>



# Probe Pin Solderless Compression Test Socket

For CGA / PGA / PGI Package

1.00 mm pitch (from 1.00 mm to 1.26 mm)

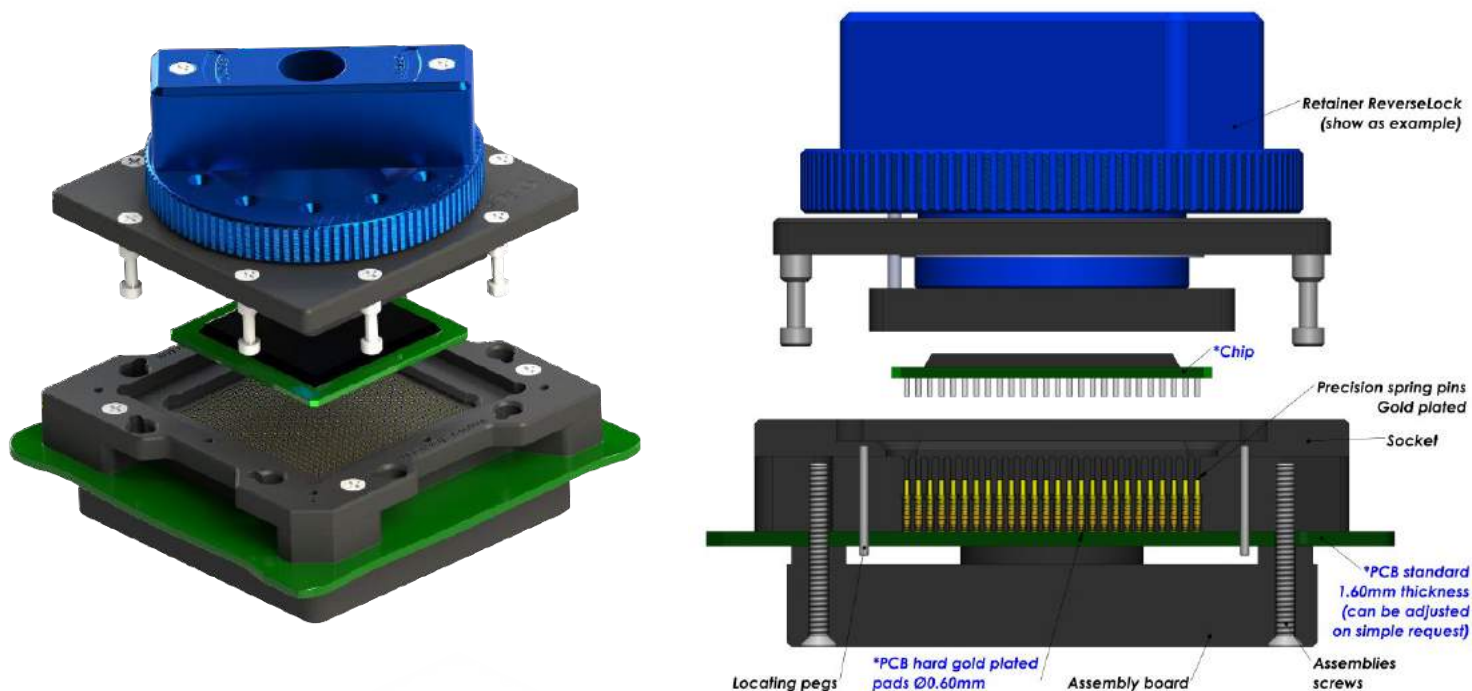
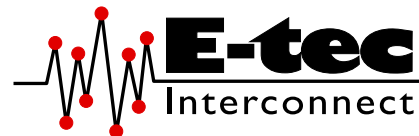

**E-tec Interconnect AG is the world leading Test socket manufacturer**

Probe Pin (Pogo) Solderless compression Test Sockets type are available for any chip size and pitch and are attached with 2, 4 or 8 screws to the PCB. The assembly board ensures perfect coplanarity of the socket. Contact reliability is guaranteed with spring loaded gold plated contacts, which are pressed onto gold plated PCB pads. Probe Pin (Pogo) Solderless compression type sockets are available with all retention systems. We aim to solve your requirements. Please note, we will always request the chip data to ensure we offer a compatible socket.

Contacts Specifications						
Contact type code	1090	1091	1092	1093	1094	1098
Application	Standard	Long Live	High Frequency	High Power	Frequency	Frequency
Mounting	Solderless	Solderless	Solderless	Solderless	Solderless	Solderless
Bandwidth (GHz@-1dB)	3 GHz	11 GHz	31 GHz	10 GHz	9.4 GHz	30.3 GHz
Contact resistance	<100 mOhm	45 mOhm	100 mOhm	30 mOhm	25 mOhm	25 mOhm
Chip contact tip shape	Single Point tip Concave tip	Crown tip	Single Point tip	Round tip	Single Point tip	Single Point tip
PCB tip shape	Single Point tip	Single Point tip	Single Point tip	Single Point tip	Spring	Spring
Force	25 gr	35 gr	33 gr	30 gr	25 gr	25 gr
Current rating	1.8 A	3 A	1 A	4 A	5 A	2.6 A
Capacitance pF	<1 pF	0.55 pF	0.39 pF	0.19 pF	0.85 pF	0.54 pF
Inductance nH	<2 nH	0.76 nH	1.01 nH	0.93 nH	1.36 nH	1.70 nH
Impedance Ohms	45 Ω	36 Ω	46 Ω	38 Ω	35 Ω	59.9 Ω
Temperature range	-55°C to +150°C	-40°C to +120°C	-50°C to +120°C	-55°C to +180°C	-55°C to +150°C	-55°C to +150°C
Mating cycles	100 K	300 K	100 K	125 K	100 K	100 K

More on the next page





# Probe Pin Solderless Compression Test Socket

For CGA / PGA / PGI Package

1.00 mm pitch (from 1.00 mm to 1.26 mm)

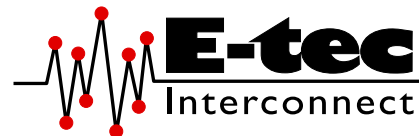

## Standard assembly boards

Small Chip size



Medium Chip size

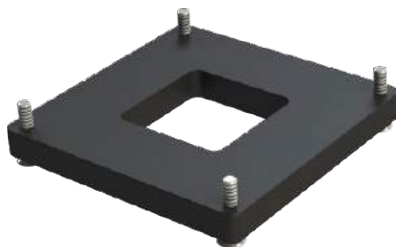

Large Chip size

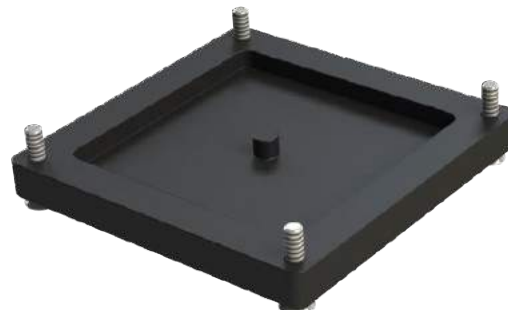

## Custom assembly boards

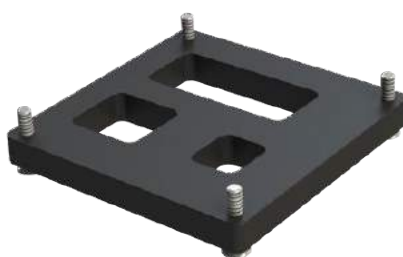
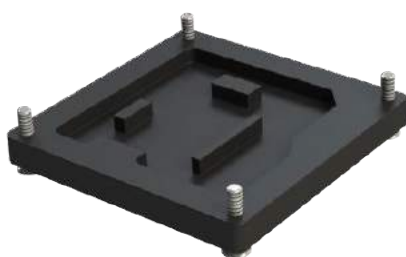

## How to order

**CU # # # # # -109# - # # # # # # 55L #**

<p><b>Shape of tip</b></p> <p>U : Concave</p> <p><b>Options:</b></p> <p>P : Pointed</p>	<p><b>Nbr of contacts</b></p> <p>Depends on ballcount of chip</p>	<p><b>Contact type</b></p> <p>91 to 98 : See "Contacts specification" chart</p> <p>90 : Standard solderless compression style</p> <p>9M: Special mixed contact style</p>	<p><b>Plating</b></p> <p>55L: Gold + Locating pegs</p> <p>Other on request</p>	<p><b>Option code</b> (see page 16-19)</p> <p>D : Dead bug</p> <p>M : Multi frames</p> <p>U : Multi packages</p> <p>C : Converter plate</p> <p>S : Custom opening slot</p> <p>H : Heatsink</p> <p>F : Fan + Heatsink</p> <p>P : Thermal drain pad</p> <p>W: Transparent lid</p> <p>I : Steel retention lid</p> <p>B : Aluminium retention lid</p> <p>T : Torque tool fixture</p> <p>G : Handling button</p>
<p><b>Retention frame type (Lid)</b> (see page 12-15)</p> <p>W: TwistLock</p> <p>F : FastLock</p> <p>B : SpringLock</p> <p>H : Open Clamshell Alu (&lt;200 contacts)</p> <p>J : Clamshell Alu (&gt;200 contacts)</p> <p>L : Open Lever Clamshell Alu (&gt;200 contacts)</p>		<p><b>Contact type</b></p> <p>S : ScrewLock</p> <p>Q : Open QuickLock (&lt;200 contacts)</p> <p>D : QuickLock (&gt;200 contacts)</p> <p>M : Injection Molded ClamShell</p> <p>R : ReverseLock</p> <p>T : SlimLock</p>		<p><b>Grid code / Config. code</b></p> <p>Will be given by the factory after receipt of the chip datasheet</p>







# Through-hole (THT) soldering Test Socket

For CGA / PGA / PGI Package

1.27 mm pitch (from 1.27 mm upwards)

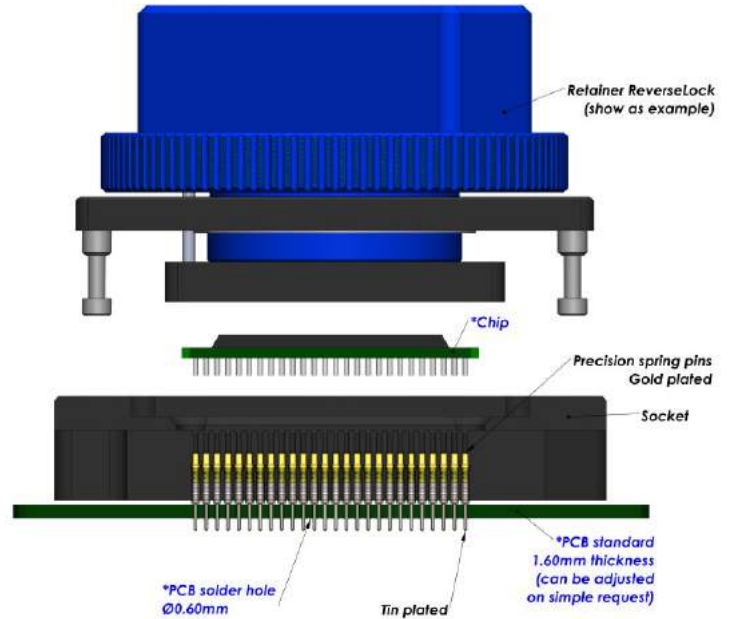
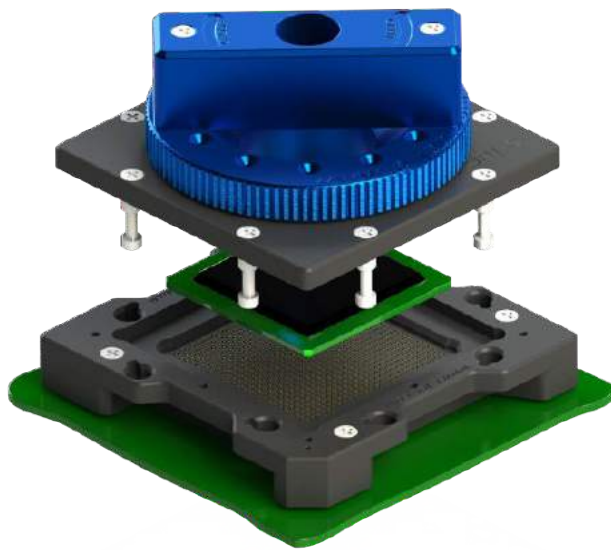

**E-tec Interconnect AG is the world leading Test socket manufacturer**

The Through-hole socket uses the same footprint as your chip. Socket is simply placed and wave soldered onto the PCB in the same way as the chip and it only requires a small amount of additional board space. Through-hole sockets are available with all retention systems. Please note, we will always request the chip data to ensure we offer a compatible socket.

Specifications contact type code 1270			
Application	Through-hole technology	Force	25 gr
Mounting	THT	Current rating	2.2 A
Bandwidth (GHz@-1dB)	3 GHz	Capacitance pF	< 1 pF
Contact resistance	<100mOhm	Inductance nH	< 2 nH
Chip contact tip shape	Single Point tip or Concave tip	Temperature range	-55°C to +150°C
PCB tip shape	Through-hole	Mating cycles	100 K

## How to order

**CU # # # # -127# - # # # # # # #5 #**

**Shape of tip**  
**U** : Concave  
**Options:**  
**P** : Pointed

**Nbr of contacts**  
 Depends on ballcount of chip

**Contact type**  
**70** : Standard THT  
**72** : Special THT to plug into MGS adapters

**Plating**  
**95**: Tin / Gold  
**55**: Gold / Gold  
 Other on request

**Option code** (see page 16-19)  
**D** : Dead bug  
**M** : Multi frames  
**U** : Multi packages  
**C** : Converter plate  
**S** : Custom opening slot  
**L** : Locating pegs  
**A** : Alignment plate  
**H** : Heatsink  
**F** : Fan + Heatsink  
**P** : Thermal drain pad  
**W** : Transparent lid  
**I** : Steel retention lid  
**B** : Aluminium retention lid  
**T** : Torque tool fixture  
**G** : Handling button

**Retention frame type (Lid)** (see page 12-15)  
**W**: TwistLock  
**F**: FastLock  
**B**: SpringLock  
**H**: Open Clamshell Alu (<200 contacts)  
**J**: Clamshell Alu (>200 contacts)  
**L**: Open Lever Clamshell Alu (>200 contacts)  
**S**: ScrewLock  
**Q**: Open QuickLock (<200 contacts)  
**D**: QuickLock (>200 contacts)  
**M**: Injection Molded ClamShell  
**R**: ReverseLock  
**T**: SlimLock

**Grid code / Config. code**  
 Will be given by the factory after receipt of the chip datasheet

# Standard SMT soldering Test Socket

For CGA / PGA / PGI Package

1.27 mm pitch (from 1.27 mm upwards)

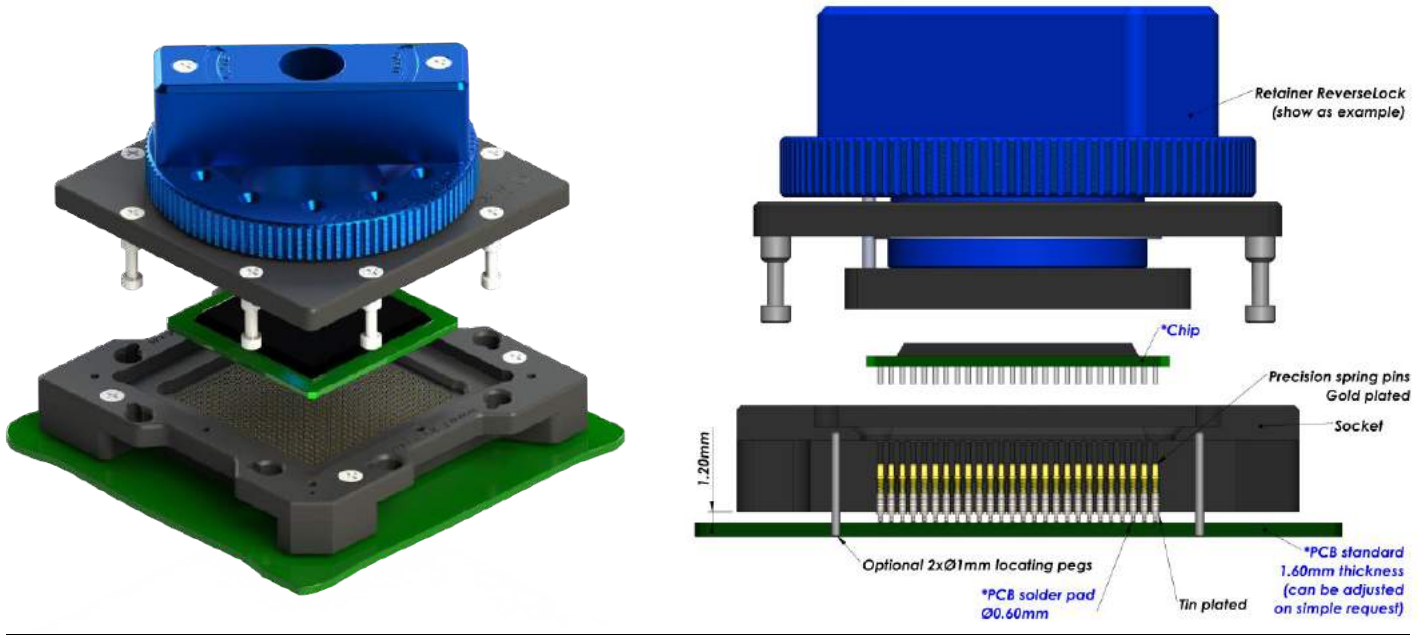
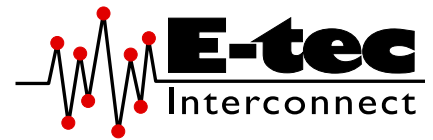

**E-tec Interconnect AG is the world leading Test socket manufacturer**

The SMT socket uses the same footprint as your chip. Socket is simply placed and reflowed onto the PCB in the same way as the chip and it only requires a small amount of additional board space. SMT type sockets are available with all retention systems. We aim to solve your requirements. Please note, we will always request the chip data to ensure we offer a compatible socket. For SMT sockets in general, E-tec Interconnect AG recommends the use of locating pegs, which can be soldered to the PCB for added mechanical strength.

Specifications contact type code 1230			
Application	Surface mouting	Force	25 gr
Mounting	SMT	Current rating	2.2 A
Bandwidth (GHz@-1dB)	3 GHz	Capacitance pF	< 1 pF
Contact resistance	<100mOhm	Inductance nH	< 2 nH
Chip contact tip shape	Single Point tip or Concave tip	Temperature range	-55°C to +150°C
PCB tip shape	SMT	Mating cycles	100 K

## How to order

**CU # #### -1230 - ##### 95 #**

<p><b>Shape of tip</b></p> <p>U : Concave</p> <p><b>Options:</b></p> <p>P : Pointed</p>	<p><b>Nbr of contacts</b></p> <p>Depends on ballcount of chip</p>	<p><b>Contact type</b></p> <p>30 : Standard SMT – Dimension A = 1.20 mm</p>	<p><b>Plating</b></p> <p>95 : Tin / Gold</p> <p>Other on request</p>	<p><b>Option code</b> (see page 16-19)</p> <p>D : Dead bug</p> <p>M : Multi frames</p> <p>U : Multi packages</p> <p>C : Converter plate</p> <p>S : Custom opening slot</p> <p>L : Locating pegs</p> <p>H : Heatsink</p> <p>F : Fan + Heatsink</p> <p>P : Thermal drain pad</p> <p>W : Transparent lid</p> <p>I : Steel retention lid</p> <p>B : Aluminium retention lid</p> <p>G : Handling button</p>
<p><b>Retention frame type (Lid)</b> (see page 12-15)</p> <p>W : TwistLock</p> <p>F : FastLock</p> <p>B : SpringLock</p> <p>H : Open Clamshell Alu (&lt;200 contacts)</p> <p>J : Clamshell Alu (&gt;200 contacts)</p> <p>L : Open Lever Clamshell Alu (&gt;200 contacts)</p>		<p><b>Grid code / Config. code</b></p> <p>Will be given by the factory after receipt of the chip datasheet</p>		
		<p>S : ScrewLock</p> <p>Q : Open QuickLock (&lt;200 contacts)</p> <p>D : QuickLock (&gt;200 contacts)</p> <p>M : Injection Molded ClamShell</p> <p>R : ReverseLock</p> <p>T : SlimLock</p>		



# Raised SMT soldering Test Socket

For CGA / PGA / PGI Package

1.27 mm pitch (from 1.27 mm upwards)

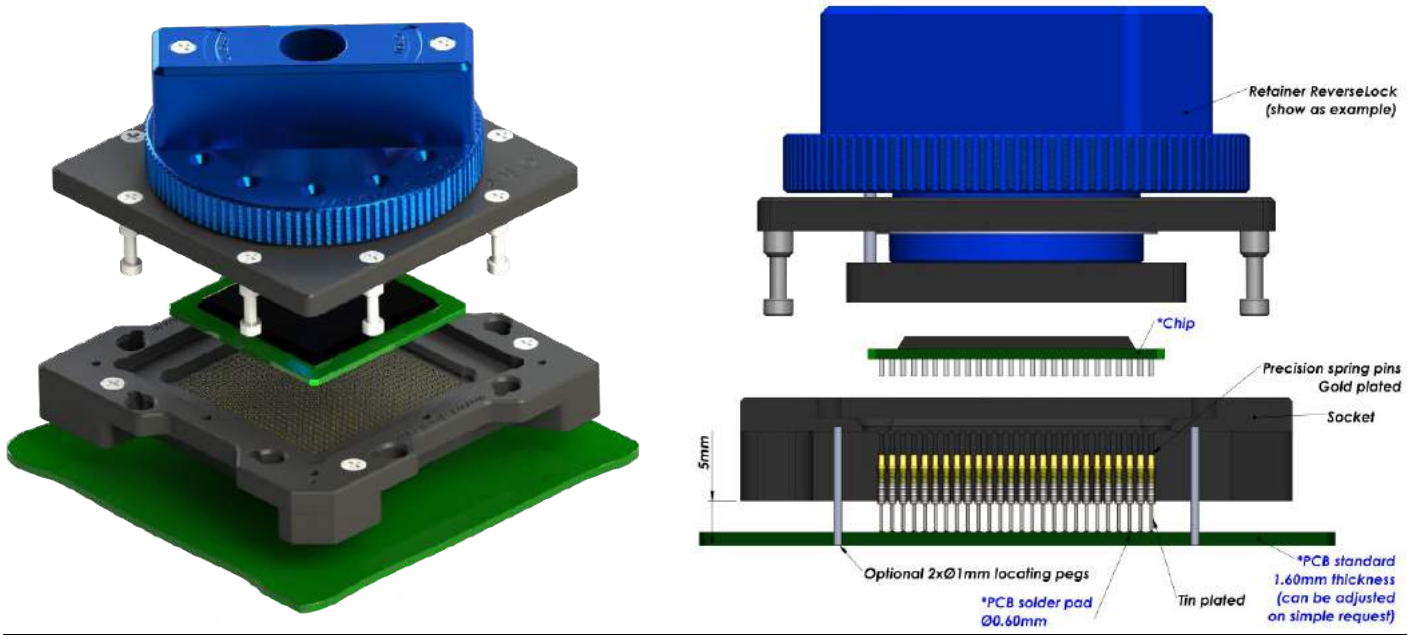
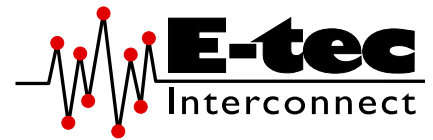

**E-tec Interconnect AG is the world leading Test socket manufacturer**

The Raised SMT socket lifts the socket above close-by components on PCB and uses the same footprint as your chip. Socket is simply placed and reflowed onto the PCB in the same way as the chip and it only requires a small amount of additional board space. Raised SMT sockets are available with all retention systems. We aim to solve your requirements. Please note, we will always request the chip data to ensure we offer a compatible socket. For Raised SMT sockets in general, E-tec Interconnect AG recommends the use of locating pegs, which can be soldered to the PCB for added mechanical strength.

Specifications contact type code 1229			
Application	Surface mouting	Force	25 gr
Mounting	Raised SMT	Current rating	2.2 A
Bandwidth (GHz@-1dB)	na	Capacitance pF	na
Contact resistance	<100mOhm	Inductance nH	na
Chip contact tip shape	Single Point tip or Concave tip	Temperature range	-55°C to +150°C
PCB tip shape	Raised SMT	Mating cycles	100 K

## How to order

**CU # #### -1229 - ##### 95A #**

<p><b>Shape of tip</b></p> <p>U : Concave</p> <p><b>Options:</b></p> <p>P : Pointed</p>	<p><b>Nbr of contacts</b></p> <p>Depends on ballcount of chip</p>	<p><b>Contact type</b></p> <p>29 : Raised SMT – Dimension A = 5.00 mm</p>	<p><b>Plating</b></p> <p>95A: Tin/Gold + Alignment plate</p> <p>Other on request</p>	<p><b>Option code</b> (see page 16-19)</p> <p>D : Dead bug</p> <p>M : Multi frames</p> <p>U : Multi packages</p> <p>C : Converter plate</p> <p>S : Custom opening slot</p> <p>L : Locating pegs</p> <p>H : Heatsink</p> <p>F : Fan + Heatsink</p> <p>P : Thermal drain pad</p> <p>W : Transparent lid</p> <p>I : Steel retention lid</p> <p>B : Aluminium retention lid</p> <p>T : Torque tool fixture</p> <p>G : Handling button</p>
<p><b>Retention frame type (Lid)</b> (see page 12-15)</p> <p>W : TwistLock</p> <p>F : FastLock</p> <p>B : SpringLock</p> <p>H : Open Clamshell Alu (&lt;200 contacts)</p> <p>J : Clamshell Alu (&gt;200 contacts)</p> <p>L : Open Lever Clamshell Alu (&gt;200 contacts)</p>		<p><b>Grid code / Config. code</b></p> <p>Will be given by the factory after receipt of the chip datasheet</p>		
		<p>S : ScrewLock</p> <p>Q : Open QuickLock (&lt;200 contacts)</p> <p>D : QuickLock (&gt;200 contacts)</p> <p>M : Injection Molded ClamShell</p> <p>R : ReverseLock</p> <p>T : SlimLock</p>		



# Probe Pin Solderless Compression Test Socket

For CGA / PGA / PGI Package

1.27 mm pitch (from 1.27 mm upwards)

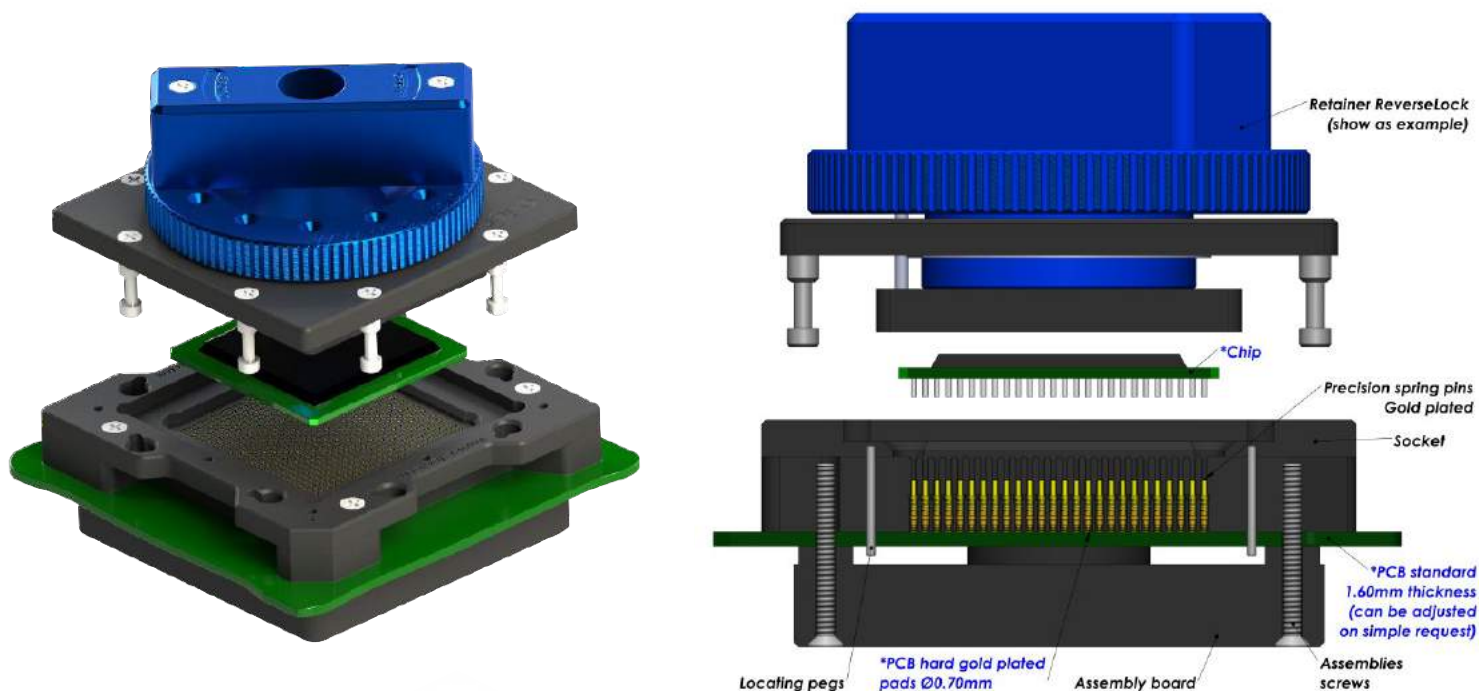
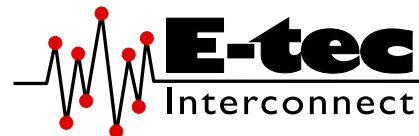

**E-tec Interconnect AG is the world leading Test socket manufacturer**

Probe Pin (Pogo) Solderless compression Test Sockets type are available for any chip size and pitch and are attached with 2, 4 or 8 screws to the PCB. The assembly board ensures perfect coplanarity of the socket. Contact reliability is guaranteed with spring loaded gold plated contacts, which are pressed onto gold plated PCB pads. Probe Pin (Pogo) Solderless compression type sockets are available with all retention systems. We aim to solve your requirements. Please note, we will always request the chip data to ensure we offer a compatible socket.

Contacts Specifications				
Contact type code	1290	1291	1294	1298
Application	Standard	High Frequency + Long Live	Frequency	Frequency
Mounting	Solderless	Solderless	Solderless	Solderless
Bandwidth (GHz@-1dB)	3 GHz	37.5 GHz	13.3 GHz	23.7 GHz
Contact resistance	<100 mOhm	45 mOhm	25 mOhm	25 mOhm
Chip contact tip shape	Single Point tip Concave tip	Crown tip	Single Point tip	Single Point tip
PCB tip shape	Single Point tip	Single Point tip	Spring	Spring
Force	25 gr	35 gr	25 gr	25 gr
Current rating	2.2 A	3 A	5 A	2.6 A
Capacitance pF	<1 pF	0.43 pF	0.76 pF	0.50 pF
Inductance nH	<2 nH	0.82 nH	1.73 nH	2.03 nH
Impedance Ohms	48 Ω	41 Ω	42.8 Ω	67.5 Ω
Temperature range	-55°C to +150°C	-40°C to +120°C	-55°C to +150°C	-55°C to +150°C
Mating cycles	100 K	300 K	100 K	100 K

More on the next page





# Probe Pin Solderless Compression Test Socket

For CGA / PGA / PGI Package

1.27 mm pitch (from 1.27 mm upwards)

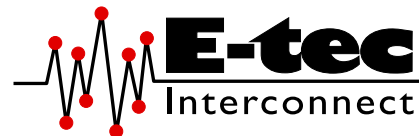

## Standard assembly boards

Small Chip size



Medium Chip size

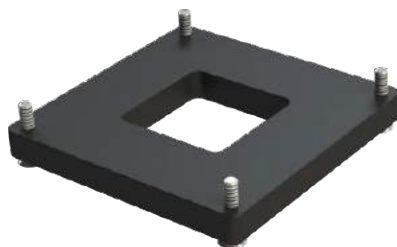

Large Chip size

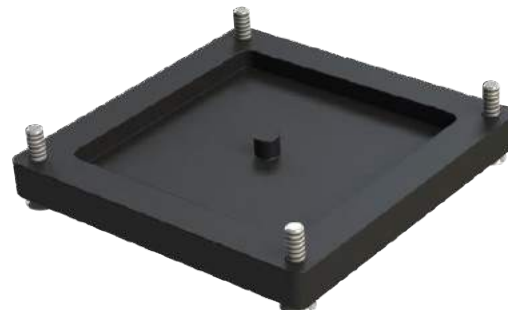

## Custom assembly boards

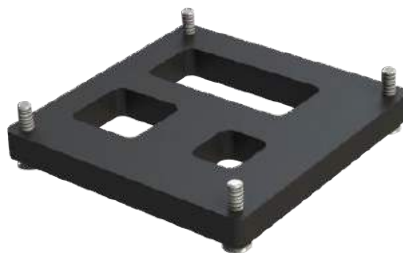
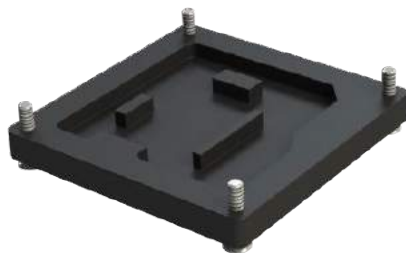

## How to order

**CU # # # # -129# - # # # # # 55L #**

<p><b>Shape of tip</b></p> <p>U : Concave</p> <p><b>Options:</b></p> <p>P : Pointed</p>	<p><b>Nbr of contacts</b></p> <p>Depends on ballcount of chip</p>	<p><b>Contact type</b></p> <p>91 to 98 : See "Contacts specification" chart</p> <p>90 : Standard solderless compression style</p> <p>9M: Special mixed contact style</p>	<p><b>Plating</b></p> <p>55L: Gold + Locating pegs</p> <p>Other on request</p>	<p><b>Option code</b> (see page 16-19)</p> <p>D : Dead bug</p> <p>M : Multi frames</p> <p>U : Multi packages</p> <p>C : Converter plate</p> <p>S : Custom opening slot</p> <p>H : Heatsink</p> <p>F : Fan + Heatsink</p> <p>P : Thermal drain pad</p> <p>W : Transparent lid</p> <p>I : Steel retention lid</p> <p>B : Aluminium retention lid</p> <p>T : Torque tool fixture</p> <p>G : Handling button</p>
<p><b>Retention frame type (Lid)</b> (see page 12-15)</p> <p>W: TwistLock</p> <p>F : FastLock</p> <p>B : SpringLock</p> <p>H : Open Clamshell Alu (&lt;200 contacts)</p> <p>J : Clamshell Alu (&gt;200 contacts)</p> <p>L : Open Lever Clamshell Alu (&gt;200 contacts)</p>		<p><b>Contact type</b></p> <p>S : ScrewLock</p> <p>Q : Open QuickLock (&lt;200 contacts)</p> <p>D : QuickLock (&gt;200 contacts)</p> <p>M : Injection Molded ClamShell</p> <p>R : ReverseLock</p> <p>T : SlimLock</p>		<p><b>Grid code / Config. code</b></p> <p>Will be given by the factory after receipt of the chip datasheet</p>

# Probe Pin Solderless Compression Test Socket

For SOP / DSO / SOIC / QFP / xQFP Package

0.40 mm pitch (from 0.40 mm to 0.49 mm)

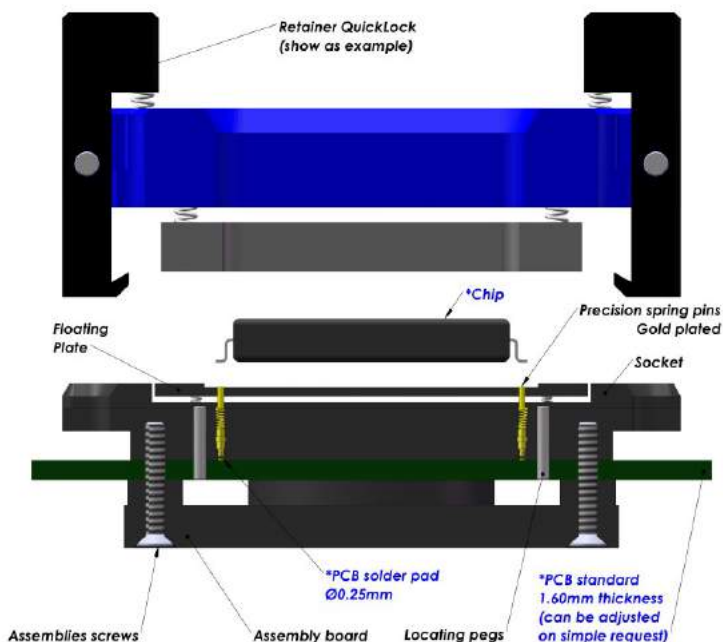
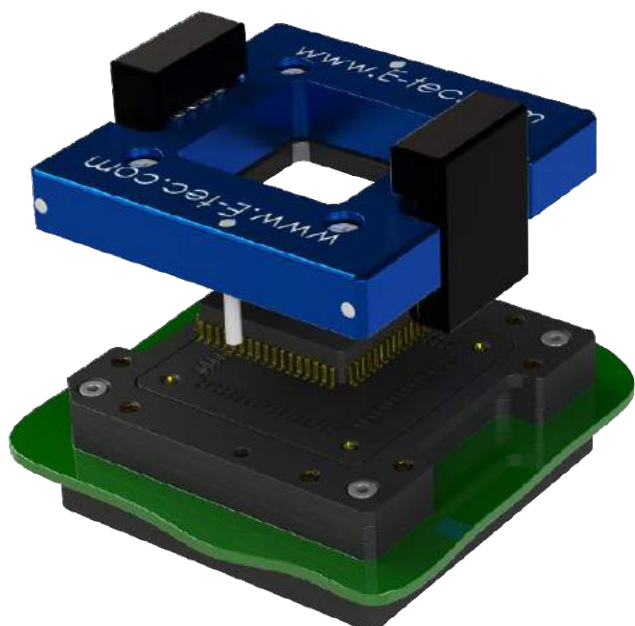
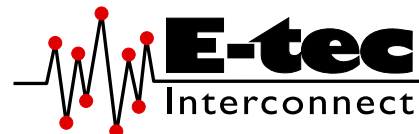

**E-tec Interconnect AG is the world leading Test socket manufacturer**

Probe Pin (Pogo) Solderless compression Test Sockets type are available for any chip size and pitch and are attached with 2, 4 or 8 screws to the PCB. The assembly board ensures perfect coplanarity of the socket. Contact reliability is guaranteed with spring loaded gold plated contacts, which are pressed onto gold plated PCB pads. Probe Pin (Pogo) Solderless compression type sockets are available with all retention systems. We aim to solve your requirements. Please note, we will always request the chip data to ensure we offer a compatible socket.

Contacts Specifications				
Contact type code	0490	0491	0492	0494
Application	Standard	Frequency	High Frequency	High Power
Mounting	Solderless	Solderless	Solderless	Solderless
Bandwidth (GHz@-1dB)	3 GHz	10 GHz	20 GHz	na
Contact resistance	<100 mOhm	100 mOhm	100 mOhm	100 mOhm
Chip contact tip shape	Single Point tip	Single Point tip	Single Point tip	Crown tip
PCB tip shape	Spring	Single Point tip	Single Point tip	Single Point tip
Force	20 gr	20 gr	20 gr	30 gr
Current rating	0.5 A	1.5 A	1.5 A	3 A
Capacitance pF	<1pF	0.90 pF	0.50 pF	na
Inductance nH	<2nH	1.50 nH	1.20 nH	na
Impedance Ohms	45 Ω	48 Ω	42 Ω	na
Temperature range	-55°C to +150°C	-40°C to +120°C	-40°C to +120°C	-40°C to +120°C
Mating cycles	100 K	300 K	100 K	100 K

More on the next page



# Probe Pin Solderless Compression Test Socket

For SOP / DSO / SOIC / QFP / xQFP Package

0.40 mm pitch (from 0.40 mm to 0.49 mm)



## Standard assembly boards

Small Chip size



Medium Chip size

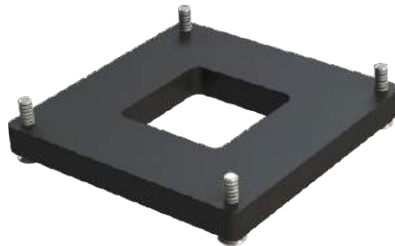

Large Chip size



## Custom assembly boards

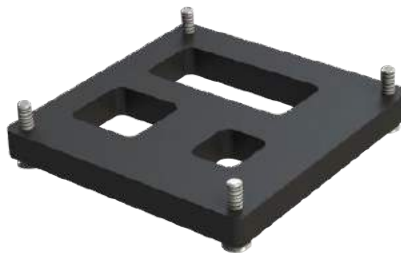
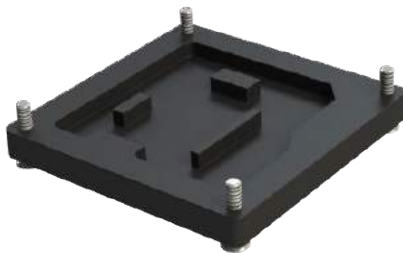

## How to order

**QU # #### -049# - ##### 55L #**

<p><b>Shape of tip</b></p> <p><b>U</b> : Concave</p> <p><b>Options:</b></p> <p><b>P</b> : Pointed</p>	<p><b>Nbr of contacts</b></p> <p>Depends on ballcount of chip</p>	<p><b>Contact type</b></p> <p><b>91 to 94</b> : See "Contacts specification" chart</p> <p><b>90</b> : Standard solderless compression style</p> <p><b>9M</b>: Special mixed contact style</p>	<p><b>Plating</b></p> <p><b>55L</b>: Gold + Locating pegs</p> <p>Other on request</p>	<p><b>Option code</b> (see page 16-19)</p> <p><b>D</b> : Dead bug</p> <p><b>M</b> : Multi frames</p> <p><b>U</b> : Multi packages</p> <p><b>S</b> : Custom opening slot</p> <p><b>H</b> : Heatsink</p> <p><b>F</b> : Fan + Heatsink</p> <p><b>P</b> : Thermal drain pad</p> <p><b>W</b> : Transparent lid</p> <p><b>I</b> : Steel retention lid</p> <p><b>B</b> : Aluminium retention lid</p> <p><b>T</b> : Torque tool fixture</p> <p><b>G</b> : Handling button</p>
<p><b>Retention frame type (Lid)</b> (see page 12-15)</p> <p><b>S</b> : ScrewLock</p> <p><b>F</b> : FastLock</p> <p><b>B</b> : SpringLock</p> <p><b>H</b> : Open Clamshell Alu (&lt;200 contacts)</p> <p><b>J</b> : Clamshell Alu (&gt;200 contacts)</p> <p><b>L</b> : Open Lever Clamshell Alu (&gt;200 contacts)</p> <p><b>Q</b> : Open QuickLock (&lt;200 contacts)</p> <p><b>D</b> : QuickLock (&gt;200 contacts)</p> <p><b>M</b> : Injection Molded ClamShell</p>		<p><b>Grid code / Config. code</b></p> <p>Will be given by the factory after receipt of the chip datasheet</p>		



# Through-hole (THT) soldering Test Socket

For SOP / DSO / SOIC / QFP / xQFP / Flatpack Package  
**0.50 mm pitch** (from 0.50 mm up to 0.79 mm)

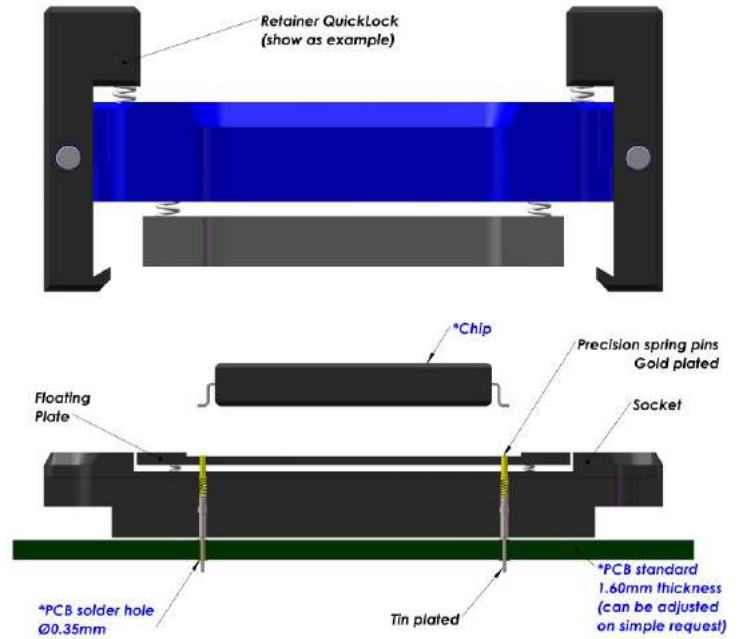
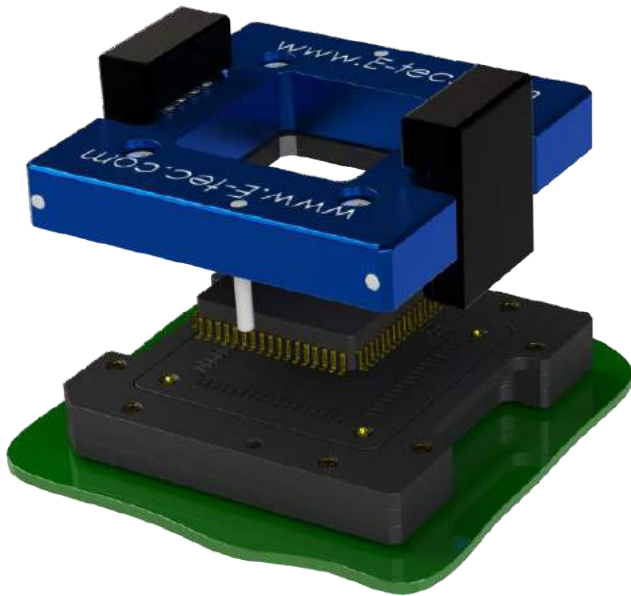
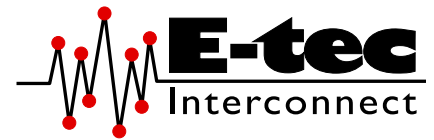

**E-tec Interconnect AG is the world leading Test socket manufacturer**

The Through-hole socket uses the same footprint as your chip. Socket is simply placed and wave soldered onto the PCB in the same way as the chip and it only requires a small amount of additional board space. Through-hole sockets are available with all retention systems. Please note, we will always request the chip data to ensure we offer a compatible socket.

Specifications contact type code 0570			
Application	Through-hole technology	Force	30 gr
Mounting	THT	Current rating	1 A
Bandwidth (GHz@-1dB)	2.7 GHz	Capacitance pF	< 1 pF
Contact resistance	<100mOhm	Inductance nH	< 2 nH
Chip contact tip shape	Single Point tip or Concave tip	Temperature range	-55°C to +150°C
PCB tip shape	Through-hole	Mating cycles	100 K

## How to order

**QU # #### -0570 - ##### 95 #**

<p><b>Shape of tip</b></p> <p>U : Concave</p> <p><b>Options:</b></p> <p>P : Pointed</p>	<p><b>Nbr of contacts</b></p> <p>Depends on ballcount of chip</p>	<p><b>Contact type</b></p> <p>70 : Standard THT</p>	<p><b>Plating</b></p> <p>95: Tin / Gold</p> <p>Other on request</p>	<p><b>Option code</b> (see page 16-19)</p> <p>D : Dead bug</p> <p>M : Multi frames</p> <p>U : Multi packages</p> <p>S : Custom opening slot</p> <p>L : Locating pegs</p> <p>A : Alignment plate</p> <p>H : Heatsink</p> <p>F : Fan + Heatsink</p> <p>P : Thermal drain pad</p> <p>W : Transparent lid</p> <p>I : Steel retention lid</p> <p>B : Aluminium retention lid</p> <p>T : Torque tool fixture</p> <p>G : Handling button</p>
<p><b>Retention frame type (Lid)</b> (see page 12-15)</p> <p>S : ScrewLock</p> <p>F : FastLock</p> <p>B : SpringLock</p> <p>H : Open Clamshell Alu (&lt;200 contacts)</p> <p>J : Clamshell Alu (&gt;200 contacts)</p> <p>L : Open Lever Clamshell Alu (&gt;200 contacts)</p> <p>Q : Open QuickLock (&lt;200 contacts)</p> <p>D : QuickLock (&gt;200 contacts)</p> <p>M : Injection Molded ClamShell</p>		<p><b>Grid code / Config. code</b></p> <p>Will be given by the factory after receipt of the chip datasheet</p>		





**Standard SMT soldering Test Socket**  
 For SOP / DSO / SOIC / QFP / xQFP / Flatpack Package  
**0.50 mm pitch** (from 0.50 mm up to 0.79 mm)

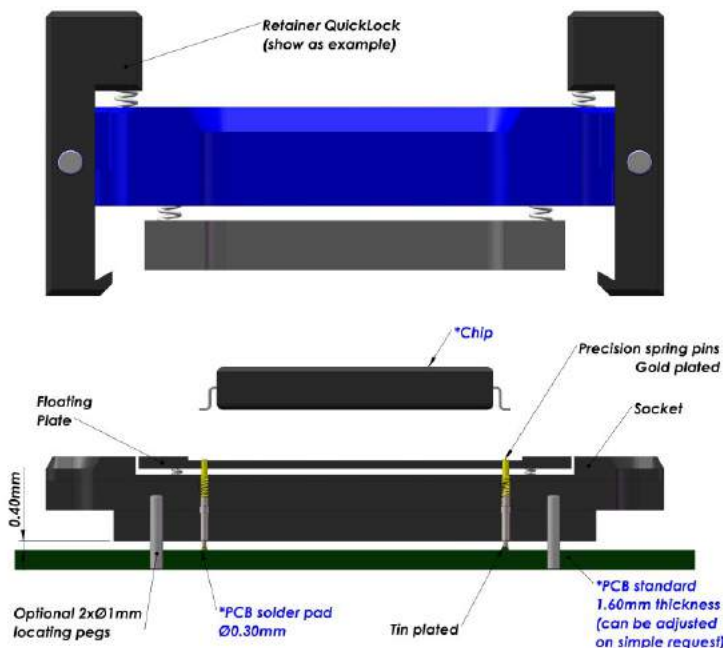
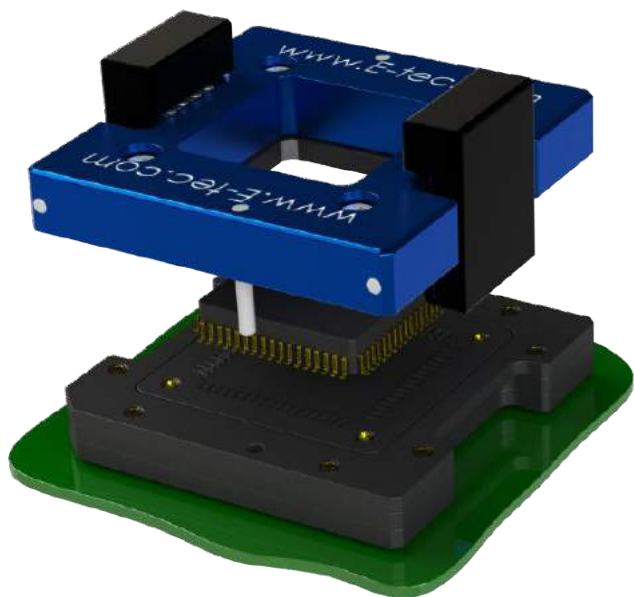
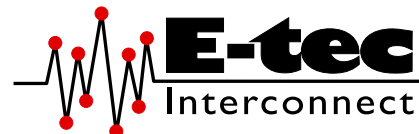

**E-tec Interconnect AG is the world leading Test socket manufacturer**

The SMT socket uses the same footprint as your chip. Socket is simply placed and reflowed onto the PCB in the same way as the chip and it only requires a small amount of additional board space. SMT type sockets are available with all retention systems. We aim to solve your requirements. Please note, we will always request the chip data to ensure we offer a compatible socket. For SMT sockets in general, E-tec Interconnect AG recommends the use of locating pegs, which can be soldered to the PCB for added mechanical strength.

Specifications contact type code 0530			
Application	Surface mouting	Force	30 gr
Mounting	SMT	Current rating	1 A
Bandwidth (GHz@-1dB)	2.7 GHz	Capacitance pF	< 1 pF
Contact resistance	<100mOhm	Inductance nH	< 2 nH
Chip contact tip shape	Single Point tip or Concave tip	Temperature range	-55°C to +150°C
PCB tip shape	SMT	Mating cycles	100 K

**How to order**

**QU # #### -0530 - ##### 95 #**

**Shape of tip**  
**U** : Concave  
**Options:**  
**P** : Pointed

**Nbr of contacts**  
 Depends on ballcount of chip

**Contact type**  
**30** : Standard SMT – Dimension A = 0.40 mm

**Plating**  
**95** : Tin / Gold  
 Other on request

**Option code** (see page 16-19)  
**D** : Dead bug  
**U** : Multi packages  
**S** : Custom opening slot  
**L** : Locating pegs  
**H** : Heatsink  
**F** : Fan + Heatsink  
**P** : Thermal drain pad  
**W** : Transparent lid  
**I** : Steel retention lid  
**T** : Torque tool fixture  
**B** : Aluminium retention lid  
**G** : Handling button

**Retention frame type (Lid)** (see page 12-15)  
**S** : ScrewLock  
**F** : FastLock  
**B** : SpringLock  
**H** : Open Clamshell Alu (<200 contacts)  
**J** : Clamshell Alu (>200 contacts)  
**L** : Open Lever Clamshell Alu (>200 contacts)  
**Q** : Open QuickLock (<200 contacts)  
**D** : QuickLock (>200 contacts)  
**M** : Injection Molded ClamShell

**Grid code / Config. code**  
 Will be given by the factory after receipt of the chip datasheet



# Raised SMT soldering Test Socket

For SOP / DSO / SOIC / QFP / xQFP, Flatpack Package  
**0.50 mm pitch** (from 0.50 mm up to 0.79 mm)

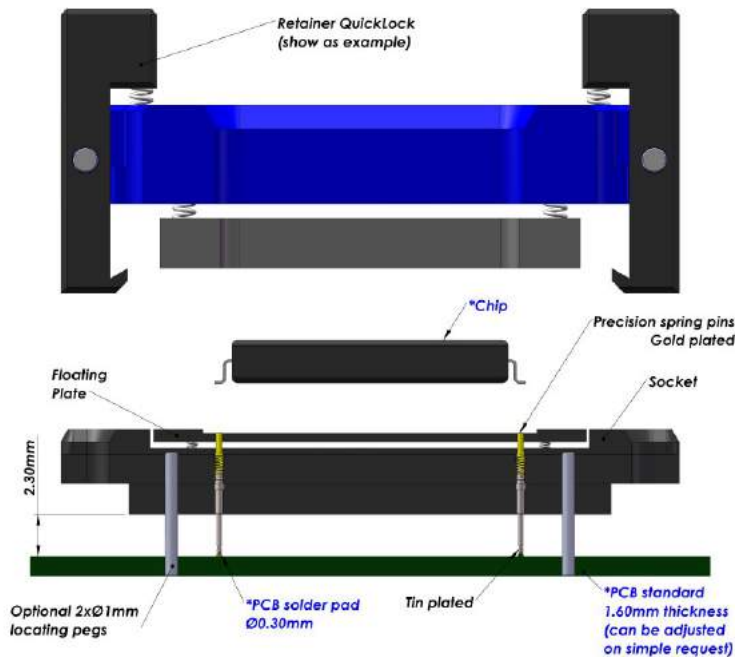
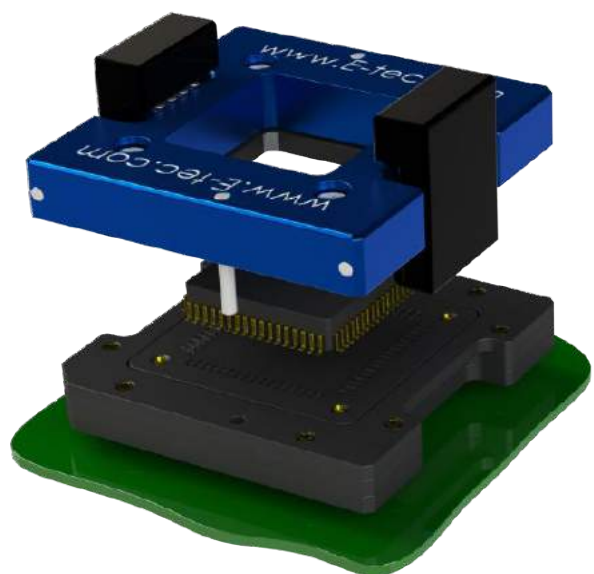
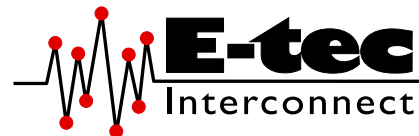

**E-tec Interconnect AG is the world leading Test socket manufacturer**

The Raised SMT socket lifts the socket above close-by components on PCB and uses the same footprint as your chip. Socket is simply placed and reflowed onto the PCB in the same way as the chip and it only requires a small amount of additional board space. Raised SMT sockets are available with all retention systems. We aim to solve your requirements. Please note, we will always request the chip data to ensure we offer a compatible socket. For Raised SMT sockets in general, E-tec Interconnect AG recommends the use of locating pegs, which can be soldered to the PCB for added mechanical strength.

Specifications contact type code 0529			
Application	Surface mouting	Force	30 gr
Mounting	Raised SMT	Current rating	1 A
Bandwidth (GHz@-1dB)	na	Capacitance pF	na
Contact resistance	<100mOhm	Inductance nH	na
Chip contact tip shape	Single Point tip or Concave tip	Temperature range	-55°C to +150°C
PCB tip shape	Raised SMT	Mating cycles	100 K

## How to order

**QU # #### -0529 - ##### 95A #**

<p><b>Shape of tip</b></p> <p>U : Concave</p> <p><b>Options:</b></p> <p>P : Pointed</p>	<p><b>Nbr of contacts</b></p> <p>Depends on ballcount of chip</p>	<p><b>Contact type</b></p> <p>29 : Raised SMT – Dimension A = 2.30 mm</p>	<p><b>Plating</b></p> <p>95A: Tin/Gold + Alignment plate</p> <p>Other on request</p>	<p><b>Option code</b> (see page 16-19)</p> <p>D : Dead bug</p> <p>U : Multi packages</p> <p>S : Custom opening slot</p> <p>L : Locating pegs</p> <p>H : Heatsink</p> <p>F : Fan + Heatsink</p> <p>P : Thermal drain pad</p> <p>W : Transparent lid</p> <p>I : Steel retention lid</p> <p>B : Aluminium retention lid</p> <p>T : Torque tool fixture</p> <p>G : Handling button</p>
<p><b>Retention frame type (Lid)</b> (see page 12-15)</p> <p>S : ScrewLock</p> <p>F : FastLock</p> <p>B : SpringLock</p> <p>H : Open Clamshell Alu (&lt;200 contacts)</p> <p>J : Clamshell Alu (&gt;200 contacts)</p> <p>L : Open Lever Clamshell Alu (&gt;200 contacts)</p>		<p><b>Grid code / Config. code</b></p> <p>Will be given by the factory after receipt of the chip datasheet</p>		
		<p>Q : Open QuickLock (&lt;200 contacts)</p> <p>D : QuickLock (&gt;200 contacts)</p> <p>M : Injection Molded ClamShell</p>		



# Probe Pin Solderless Compression Test Socket

For SOP / DSO / SOIC / QFP / xQFP Package

0.50 mm pitch (from 0.50 mm to 0.79 mm)

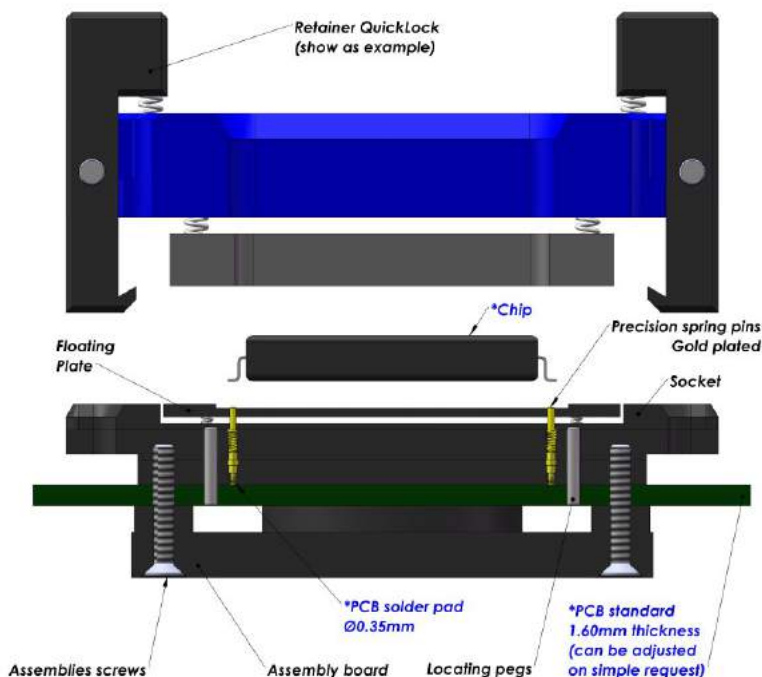
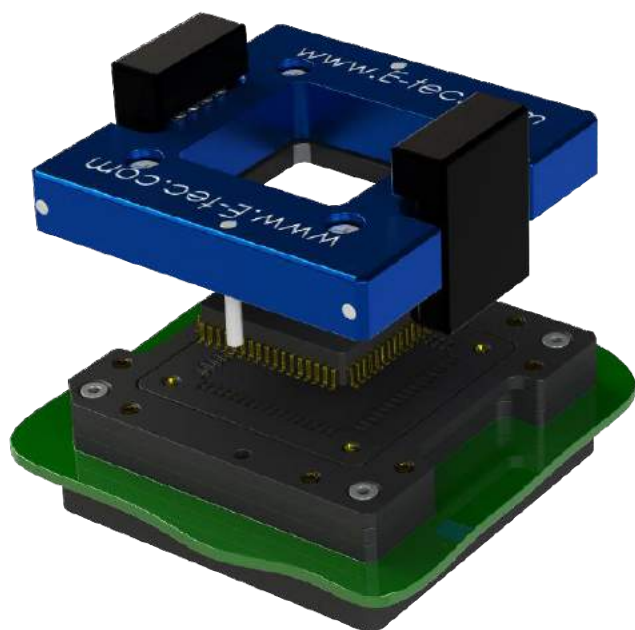
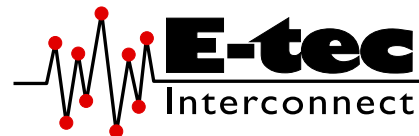

**E-tec Interconnect AG is the world leading Test socket manufacturer**

Probe Pin (Pogo) Solderless compression Test Sockets type are available for any chip size and pitch and are attached with 2, 4 or 8 screws to the PCB. The assembly board ensures perfect coplanarity of the socket. Contact reliability is guaranteed with spring loaded gold plated contacts, which are pressed onto gold plated PCB pads. Probe Pin (Pogo) Solderless compression type sockets are available with all retention systems. We aim to solve your requirements. Please note, we will always request the chip data to ensure we offer a compatible socket.

Contacts Specifications						
Contact type code	0590	0591	0592	0593	0594	0598
Application	Standard	Long live	High Frequency	High Temp & Long live	High Power	SuperHigh Frequency
Mounting	Solderless	Solderless	Solderless	Solderless	Solderless	Solderless
Bandwidth (GHz@-1dB)	3 GHz	7 GHz	29 GHz	8.9 GHz	9 GHz	40 GHz
Contact resistance	<100 mOhm	40 mOhm	100 mOhm	80 mOhm	80 mOhm	100 mOhm
Chip contact tip shape	Single Point tip Concave tip	Crown tip	Single Point tip	Crown tip	Crown tip	Single Point tip
PCB tip shape	Single Point tip	Single Point tip	Single Point tip	Single Point tip	Single Point tip	Spring
Force	30 gr	23 gr	20 gr	23 gr	30 gr	20 gr
Current rating	1.5 A	1 A	1.5 A	2 A	2 A	0.5 A
Capacitance pF	<1 pF	0.45 pF	0.48 pF	0.71 pF	na	0.36 pF
Inductance nH	<2 nH	1.08 nH	0.89 nH	0.67 nH	na	1.19 nH
Impedance Ohms	38 Ω	39 Ω	38 Ω	55 Ω	60 Ω	62 Ω
Temperature range	-55°C to +150°C	-50°C to +150°C	-40°C to +120°C	-50°C to +220°C	-50°C to +220°C	-55°C to +150°C
Mating cycles	100 K	300 K	100 K	500 K	500 K	100 K

More on the next page



# Probe Pin Solderless Compression Test Socket

For SOP / DSO / SOIC / QFP / xQFP Package

0.50 mm pitch (from 0.50 mm to 0.79 mm)



## Standard assembly boards

Small Chip size



Medium Chip size

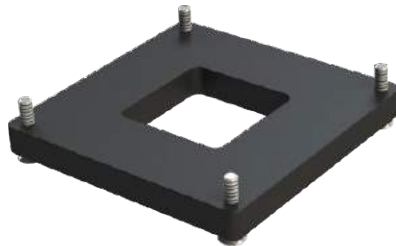

Large Chip size

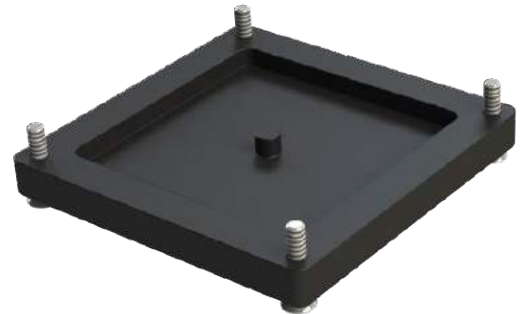

## Custom assembly boards

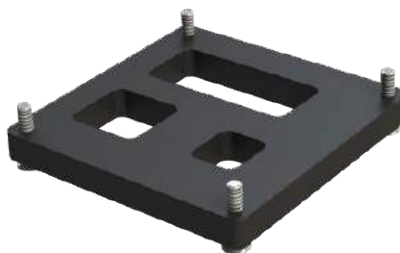
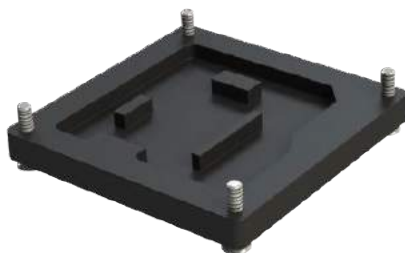

## How to order

**QU # # # # -059# - # # # # # 55L #**

**Shape of tip**

**U** : Concave

**Options:**

**P** : Pointed

**Nbr of contacts**

Depends on ballcount of chip

**Contact type**

**91 to 98** : See "Contacts specification" chart

**90** : Standard solderless compression style

**9M**: Special mixed contact style

**Plating**

**55L**: Gold + Locating pegs

Other on request

**Option code** (see page 16-19)

**D** : Dead bug

**M** : Multi frames

**U** : Multi packages

**S** : Custom opening slot

**H** : Heatsink

**F** : Fan + Heatsink

**P** : Thermal drain pad

**W** : Transparent lid

**I** : Steel retention lid

**B** : Aluminium retention lid

**T** : Torque tool fixture

**G** : Handling button

**Retention frame type (Lid)** (see page 12-15)

**S** : ScrewLock

**F** : FastLock

**B** : SpringLock

**H** : Open Clamshell Alu (<200 contacts)

**J** : Clamshell Alu (>200 contacts)

**L** : Open Lever Clamshell Alu (>200 contacts)

**Q** : Open QuickLock (<200 contacts)

**D** : QuickLock (>200 contacts)

**M** : Injection Molded ClamShell

**Grid code / Config. code**

Will be given by the factory after receipt of the chip datasheet







# Through-hole (THT) soldering Test Socket

For SOP / DSO / SOIC / QFP / xQFP / Flatpack Package  
**0.80 mm pitch** (from 0.80 mm up to 0.99 mm)

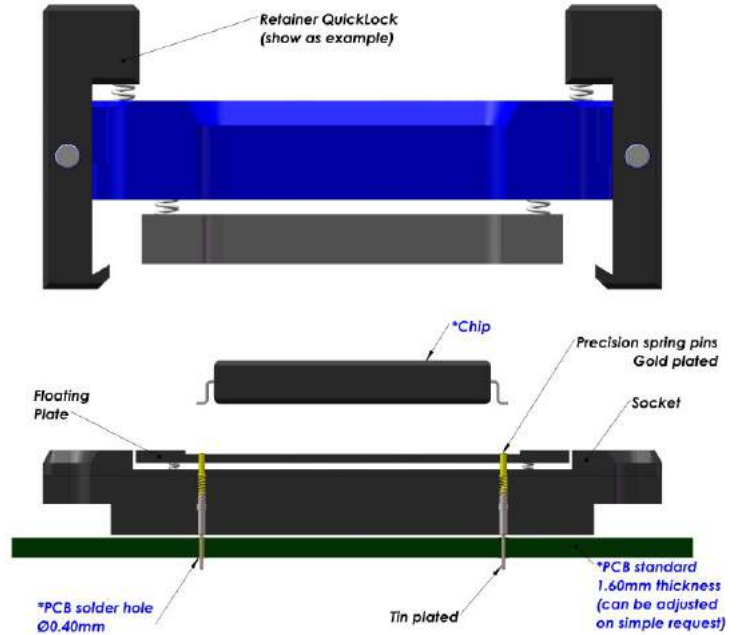
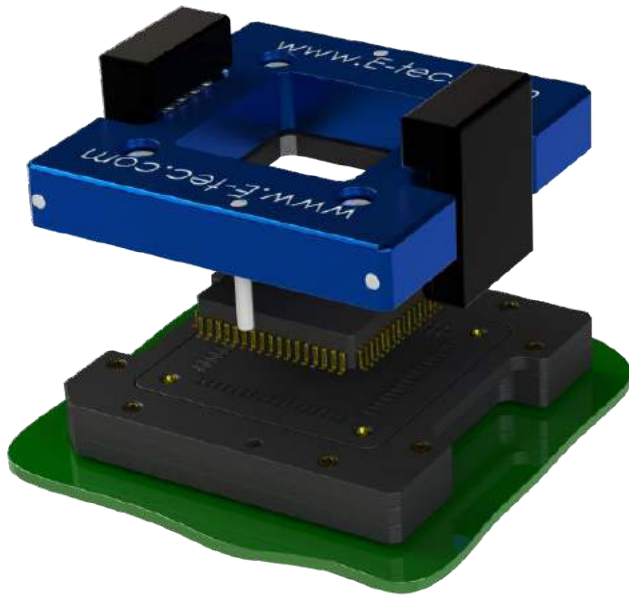
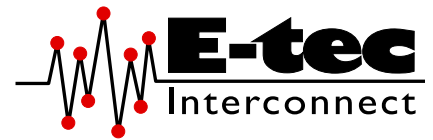

**E-tec Interconnect AG is the world leading Test socket manufacturer**

The Through-hole socket uses the same footprint as your chip. Socket is simply placed and wave soldered onto the PCB in the same way as the chip and it only requires a small amount of additional board space. Through-hole sockets are available with all retention systems. Please note, we will always request the chip data to ensure we offer a compatible socket.

Specifications contact type code 0870			
Application	Through-hole technology	Force	30 gr
Mounting	THT	Current rating	1.8 A
Bandwidth (GHz@-1dB)	3.4 GHz	Capacitance pF	0.59 pF
Contact resistance	<100mOhm	Inductance nH	1.70 nH
Chip contact tip shape	Single Point tip or Concave tip	Temperature range	-55°C to +150°C
PCB tip shape	Through-hole	Mating cycles	100 K

## How to order

**QU # # # # # -087# - # # # # # # # #5 #**

<p><b>Shape of tip</b></p> <p>U : Concave</p> <p><b>Options:</b></p> <p>P : Pointed</p>	<p><b>Nbr of contacts</b></p> <p>Depends on ballcount of chip</p>	<p><b>Contact type</b></p> <p>70 : Standard THT</p> <p>72 : Special THT to plug into MGS adapters</p>	<p><b>Plating</b></p> <p>95: Tin / Gold</p> <p>55: Gold / Gold</p> <p>Other on request</p>	<p><b>Option code</b> (see page 16-19)</p> <p>D : Dead bug</p> <p>M : Multi frames</p> <p>U : Multi packages</p> <p>S : Custom opening slot</p> <p>L : Locating pegs</p> <p>A : Alignment plate</p> <p>H : Heatsink</p> <p>F : Fan + Heatsink</p> <p>P : Thermal drain pad</p> <p>W : Transparent lid</p> <p>I : Steel retention lid</p> <p>B : Aluminium retention lid</p> <p>T : Torque tool fixture</p> <p>G : Handling button</p>
<p><b>Retention frame type (Lid)</b> (see page 12-15)</p> <p>S : ScrewLock</p> <p>F : FastLock</p> <p>B : SpringLock</p> <p>H : Open Clamshell Alu (&lt;200 contacts)</p> <p>J : Clamshell Alu (&gt;200 contacts)</p> <p>L : Open Lever Clamshell Alu (&gt;200 contacts)</p>		<p><b>Grid code / Config. code</b></p> <p>Will be given by the factory after receipt of the chip datasheet</p>		
		<p>Q : Open QuickLock (&lt;200 contacts)</p> <p>D : QuickLock (&gt;200 contacts)</p> <p>M : Injection Molded ClamShell</p>		



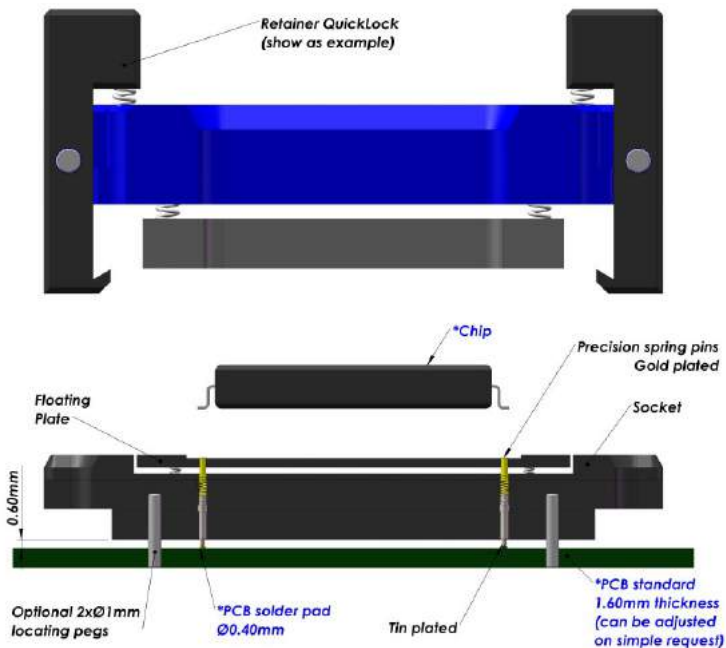
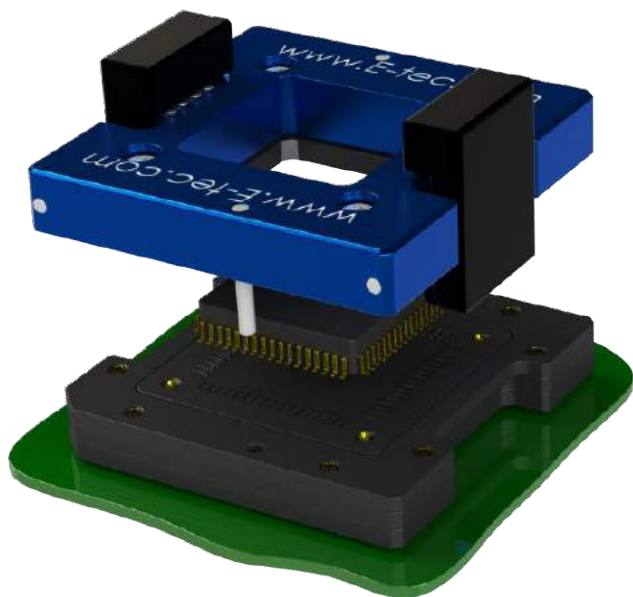

**E-tec Interconnect AG is the world leading Test socket manufacturer**

The SMT socket uses the same footprint as your chip. Socket is simply placed and reflowed onto the PCB in the same way as the chip and it only requires a small amount of additional board space. SMT type sockets are available with all retention systems. We aim to solve your requirements. Please note, we will always request the chip data to ensure we offer a compatible socket. For SMT sockets in general, E-tec Interconnect AG recommends the use of locating pegs, which can be soldered to the PCB for added mechanical strength.

Specifications contact type code 0830			
Application	Surface mouting	Force	30 gr
Mounting	SMT	Current rating	1.8 A
Bandwidth (GHz@-1dB)	2.6(4.4) GHz	Capacitance pF	0.59 pF
Contact resistance	<100mOhm	Inductance nH	1.70 nH
Chip contact tip shape	Single Point tip or Concave tip	Temperature range	-55°C to +150°C
PCB tip shape	SMT	Mating cycles	100 K

**How to order**

**QU # ### -0830 - ##### 95 #**

<p><b>Shape of tip</b></p> <p>U : Concave</p> <p><b>Options:</b></p> <p>P : Pointed</p>	<p><b>Nbr of contacts</b></p> <p>Depends on ballcount of chip</p>	<p><b>Contact type</b></p> <p>30 : Standard SMT – Dimension A = 0.60 mm</p>	<p><b>Plating</b></p> <p>95 : Tin / Gold</p> <p>Other on request</p>	<p><b>Option code</b> (see page 16-19)</p> <p>D : Dead bug</p> <p>U : Multi packages</p> <p>S : Custom opening slot</p> <p>L : Locating pegs</p> <p>H : Heatsink</p> <p>F : Fan + Heatsink</p> <p>P : Thermal drain pad</p> <p>W : Transparent lid</p> <p>I : Steel retention lid</p> <p>T : Torque tool fixture</p> <p>B : Aluminium retention lid</p> <p>G : Handling button</p>
<p><b>Retention frame type (Lid)</b> (see page 12-15)</p> <p>S : ScrewLock</p> <p>F : FastLock</p> <p>B : SpringLock</p> <p>H : Open Clamshell Alu (&lt;200 contacts)</p> <p>J : Clamshell Alu (&gt;200 contacts)</p> <p>L : Open Lever Clamshell Alu (&gt;200 contacts)</p>		<p><b>Grid code / Config. code</b></p> <p>Will be given by the factory after receipt of the chip datasheet</p>		
		<p>Q : Open QuickLock (&lt;200 contacts)</p> <p>D : QuickLock (&gt;200 contacts)</p> <p>M : Injection Molded ClamShell</p>		

# Raised SMT soldering Test Socket

For SOP / DSO / SOIC / QFP / xQFP, Flatpack Package  
**0.80 mm pitch** (from 0.80 mm up to 0.99 mm)

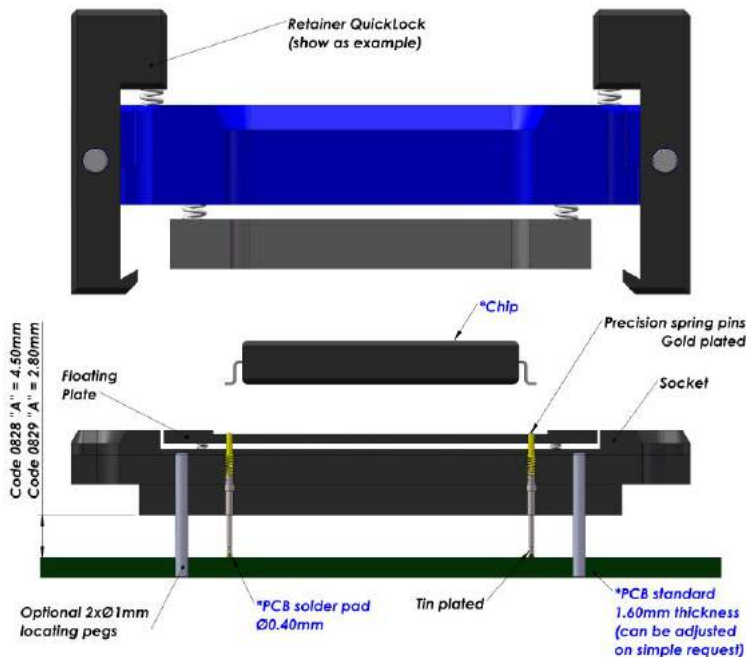
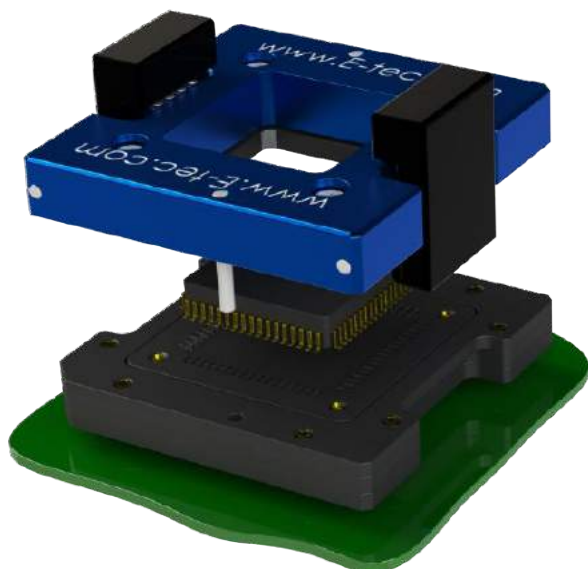
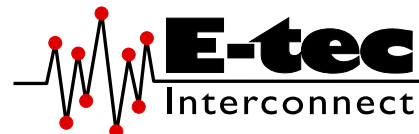

**E-tec Interconnect AG is the world leading Test socket manufacturer**

The Raised SMT socket lifts the socket above close-by components on PCB and uses the same footprint as your chip. Socket is simply placed and reflowed onto the PCB in the same way as the chip and it only requires a small amount of additional board space. Raised SMT sockets are available with all retention systems. We aim to solve your requirements. Please note, we will always request the chip data to ensure we offer a compatible socket. For Raised SMT sockets in general, E-tec Interconnect AG recommends the use of locating pegs, which can be soldered to the PCB for added mechanical strength.

Specifications contact type code 0829 & 0828			
Application	Surface mouting	Force	30 gr
Mounting	Raised SMT	Current rating	1.8 A
Bandwidth (GHz@-1dB)	na	Capacitance pF	na
Contact resistance	<100mOhm	Inductance nH	na
Chip contact tip shape	Single Point tip or Concave tip	Temperature range	-55°C to +150°C
PCB tip shape	Raised SMT	Mating cycles	100 K

## How to order

**QU # # # # -082# - # # # # # 95A #**

<p><b>Shape of tip</b></p> <p>U : Concave</p> <p><b>Options:</b></p> <p>P : Pointed</p>	<p><b>Nbr of contacts</b></p> <p>Depends on ballcount of chip</p>	<p><b>Contact type</b></p> <p>29 : Raised SMT – Dimension A = 2.80 mm</p> <p>28 : Special Raised SMT - Dim. A = 4.50 mm</p>	<p><b>Plating</b></p> <p>95A: Tin/Gold + Alignment plate</p> <p>Other on request</p>	<p><b>Option code</b> (see page 16-19)</p> <p>D : Dead bug</p> <p>U : Multi packages</p> <p>S : Custom opening slot</p> <p>L : Locating pegs</p> <p>H : Heatsink</p> <p>F : Fan + Heatsink</p> <p>P : Thermal drain pad</p> <p>W : Transparent lid</p> <p>I : Steel retention lid</p> <p>B : Aluminium retention lid</p> <p>T : Torque tool fixture</p> <p>G : Handling button</p>
<p><b>Retention frame type (Lid)</b> (see page 12-15)</p> <p>S : ScrewLock</p> <p>F : FastLock</p> <p>B : SpringLock</p> <p>H : Open Clamshell Alu (&lt;200 contacts)</p> <p>J : Clamshell Alu (&gt;200 contacts)</p> <p>L : Open Lever Clamshell Alu (&gt;200 contacts)</p>		<p><b>Grid code / Config. code</b></p> <p>Will be given by the factory after receipt of the chip datasheet</p>		
		<p>Q : Open QuickLock (&lt;200 contacts)</p> <p>D : QuickLock (&gt;200 contacts)</p> <p>M : Injection Molded ClamShell</p>		



# Probe Pin Solderless Compression Test Socket

For SOP / DSO / SOIC / QFP / xQFP Package

0.80 mm pitch (from 0.80 mm to 0.99 mm)

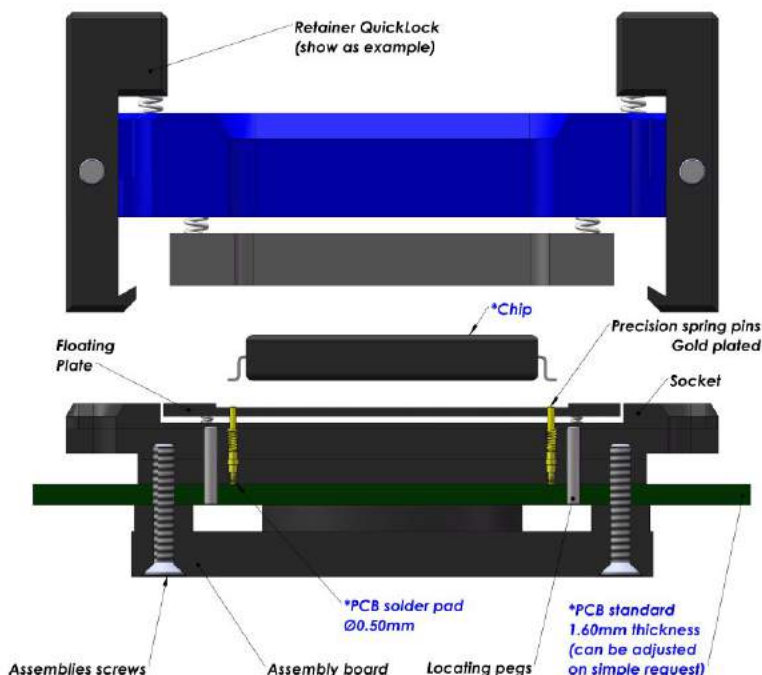
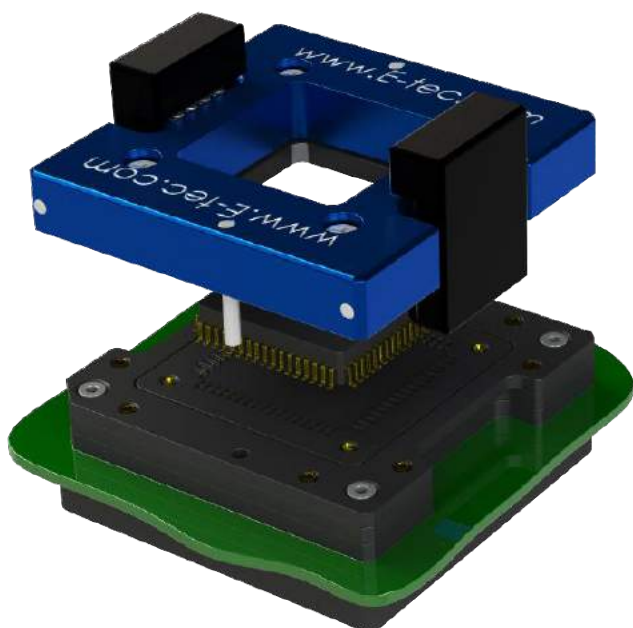
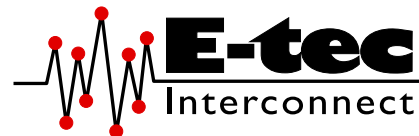

**E-tec Interconnect AG is the world leading Test socket manufacturer**

Probe Pin (Pogo) Solderless compression Test Sockets type are available for any chip size and pitch and are attached with 2, 4 or 8 screws to the PCB. The assembly board ensures perfect coplanarity of the socket. Contact reliability is guaranteed with spring loaded gold plated contacts, which are pressed onto gold plated PCB pads. Probe Pin (Pogo) Solderless compression type sockets are available with all retention systems. We aim to solve your requirements. Please note, we will always request the chip data to ensure we offer a compatible socket.

Contacts Specifications						
Contact type code	0890	0891	0893	0892	0894	0898
Application	Standard	High Frequency	Low Contact Resistance	High Frequency	Frequency	Frequency
Mounting	Solderless	Solderless	Solderless	Solderless	Solderless	Solderless
Bandwidth (GHz@-1dB)	3.4 GHz	36 GHz	7 GHz	31 GHz	14 GHz	31.7 GHz
Contact resistance	<100 mOhm	100 mOhm	40 mOhm	90 mOhm	90 mOhm	25 mOhm
Chip contact tip shape	Single Point tip Concave tip	Single Point tip	Crown tip	Single Point tip	Single Point tip	Single Point tip
PCB tip shape	Single Point tip	Single Point tip	Single Point tip	Spring	Spring	Spring
Force	30 gr	33 gr	23 gr	20 gr	20 gr	25 gr
Current rating	1.8 A	1 A	1 A	0.5 A	0.5 A	2.6 A
Capacitance pF	<1 pF	0.47 pF	0.55 pF	0.37 pF	0.30 pF	0.60 pF
Inductance nH	<2 nH	0.93 nH	1.08 nH	1.67 nH	1.66 nH	1.38 nH
Impedance Ohms	40 Ω	38 Ω	39 Ω	73 Ω	78 Ω	44.8 Ω
Temperature range	-55°C to +150°C	-40°C to +120°C	-50°C to +150°C	-55°C to +150°C	-55°C to +150°C	-55°C to +150°C
Mating cycles	100 K	100 K	100 K	100 K	100 K	100 K

More on the next page



# Probe Pin Solderless Compression Test Socket

For SOP / DSO / SOIC / QFP / xQFP Package

0.80 mm pitch (from 0.80 mm to 0.99 mm)

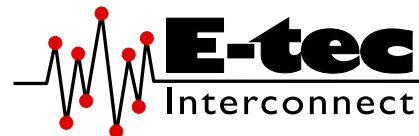

## Standard assembly boards

Small Chip size



Medium Chip size

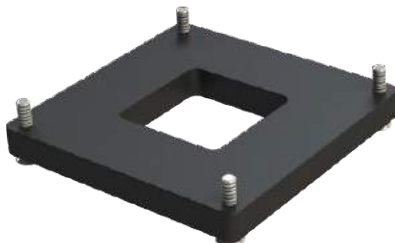

Large Chip size

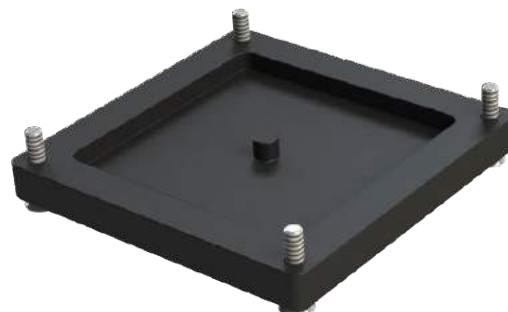

## Custom assembly boards

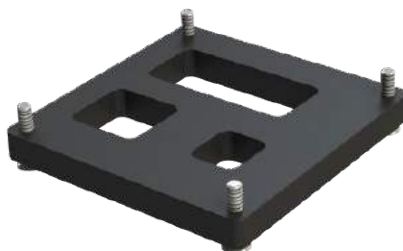
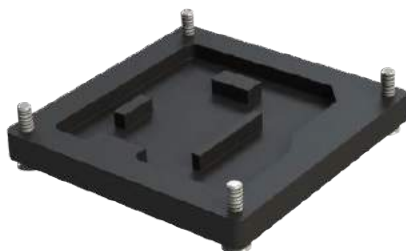

## How to order

**QU # #### -089# - ##### 55L #**

**Shape of tip**

**U** : Concave

**Options:**

**P** : Pointed

**Nbr of contacts**

Depends on ballcount of chip

**Contact type**

**91 to 98** : See "Contacts specification" chart

**90** : Standard solderless compression style

**9M**: Special mixed contact style

**Plating**

**55L**: Gold + Locating pegs

Other on request

**Option code** (see page 16-19)

**D** : Dead bug

**M** : Multi frames

**U** : Multi packages

**S** : Custom opening slot

**H** : Heatsink

**F** : Fan + Heatsink

**P** : Thermal drain pad

**W** : Transparent lid

**I** : Steel retention lid

**B** : Aluminium retention lid

**T** : Torque tool fixture

**G** : Handling button

**Retention frame type (Lid)** (see page 12-15)

**S** : ScrewLock

**F** : FastLock

**B** : SpringLock

**H** : Open Clamshell Alu (<200 contacts)

**J** : Clamshell Alu (>200 contacts)

**L** : Open Lever Clamshell Alu (>200 contacts)

**Q** : Open QuickLock (<200 contacts)

**D** : QuickLock (>200 contacts)

**M** : Injection Molded ClamShell

**Grid code / Config. code**

Will be given by the factory after receipt of the chip datasheet







# Through-hole (THT) soldering Test Socket

For SOP / DSO / SOIC / QFP / xQFP / Flatpack Package  
**1.00 mm pitch** (from 1.00 mm up to 1.26 mm)

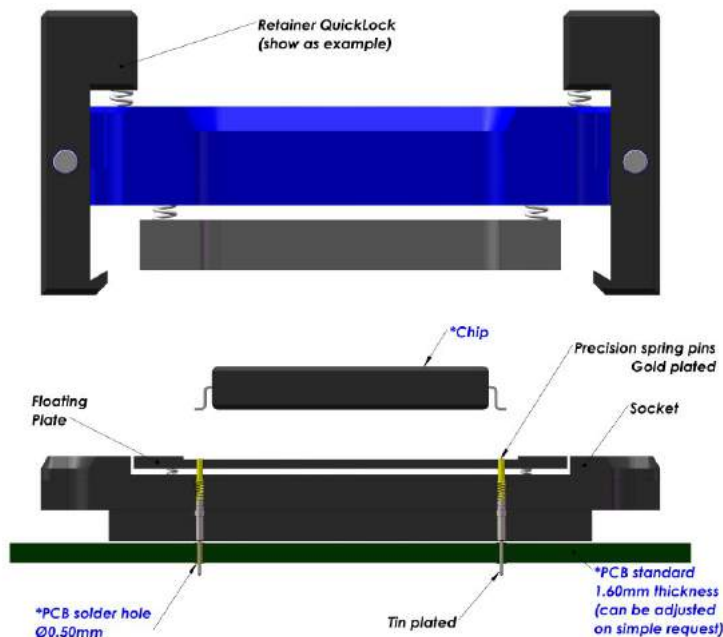
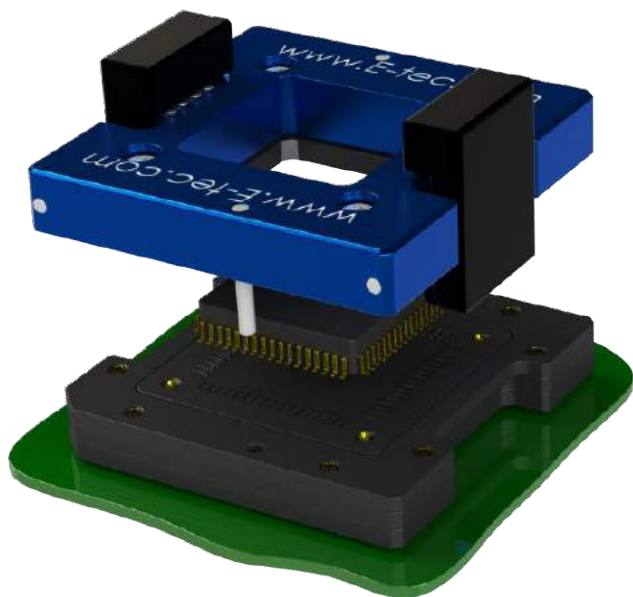
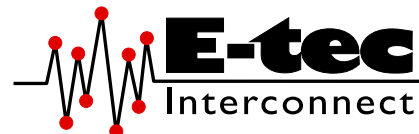

**E-tec Interconnect AG is the world leading Test socket manufacturer**

The Through-hole socket uses the same footprint as your chip. Socket is simply placed and wave soldered onto the PCB in the same way as the chip and it only requires a small amount of additional board space. Through-hole sockets are available with all retention systems. Please note, we will always request the chip data to ensure we offer a compatible socket.

Specifications contact type code 1070			
<b>Application</b>	Through-hole technology	<b>Force</b>	25 gr
<b>Mounting</b>	THT	<b>Current rating</b>	1.8 A
<b>Bandwidth (GHz@-1dB)</b>	3.4 GHz	<b>Capacitance pF</b>	1.03 pF
<b>Contact resistance</b>	<100mOhm	<b>Inductance nH</b>	1.80 nH
<b>Chip contact tip shape</b>	Single Point tip or Concave tip	<b>Temperature range</b>	-55°C to +150°C
<b>PCB tip shape</b>	Through-hole	<b>Mating cycles</b>	100 K

## How to order

**QU # #### -107# - ##### #5 #**

### Shape of tip

**U** : Concave

#### Options:

**P** : Pointed

### Nbr of contacts

Depends on ballcount of chip

### Contact type

**70** : Standard THT

**72** : Special THT to plug into MGS adapters

### Plating

**95**: Tin / Gold

**55**: Gold / Gold

Other on request

### Option code (see page 16-19)

**D** : Dead bug

**M** : Multi frames

**U** : Multi packages

**S** : Custom opening slot

**L** : Locating pegs

**A** : Alignment plate

**H** : Heatsink

**F** : Fan + Heatsink

**P** : Thermal drain pad

**W** : Transparent lid

**I** : Steel retention lid

**B** : Aluminium retention lid

**T** : Torque tool fixture

**G** : Handling button

### Retention frame type (Lid) (see page 12-15)

**S** : ScrewLock

**F** : FastLock

**B** : SpringLock

**H** : Open Clamshell Alu (<200 contacts)

**J** : Clamshell Alu (>200 contacts)

**L** : Open Lever Clamshell Alu (>200 contacts)

**Q** : Open QuickLock (<200 contacts)

**D** : QuickLock (>200 contacts)

**M** : Injection Molded ClamShell

### Grid code / Config. code

Will be given by the factory after receipt of the chip datasheet



**Standard SMT soldering Test Socket**  
 For SOP / DSO / SOIC / QFP / xQFP / Flatpack Package  
**1.00 mm pitch** (from 1.00 mm up to 1.26 mm)

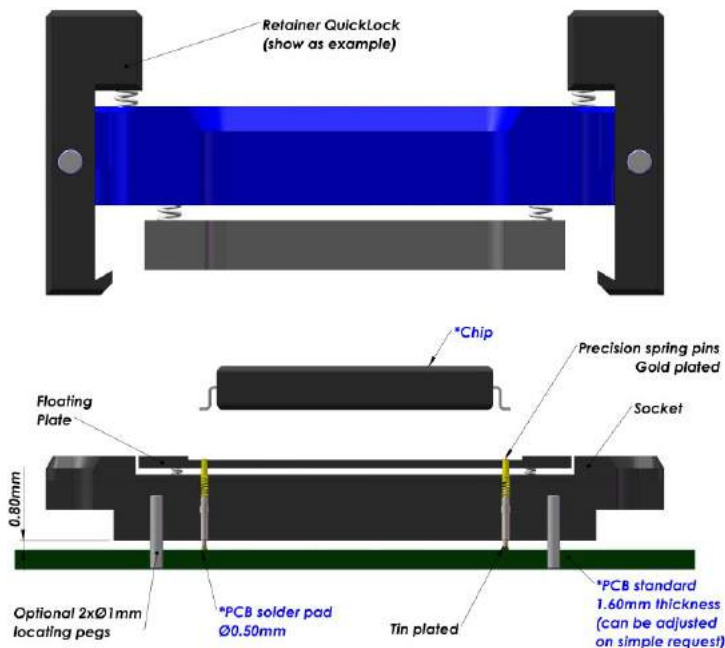
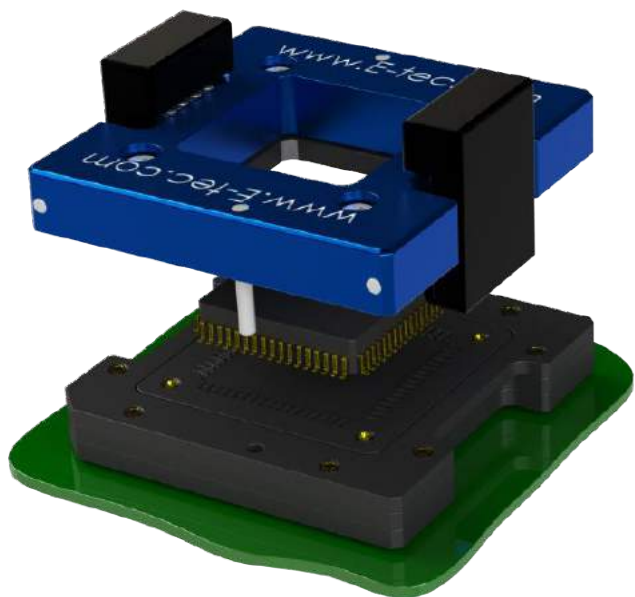
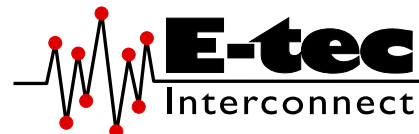

**E-tec Interconnect AG is the world leading Test socket manufacturer**

The SMT socket uses the same footprint as your chip. Socket is simply placed and reflowed onto the PCB in the same way as the chip and it only requires a small amount of additional board space. SMT type sockets are available with all retention systems. We aim to solve your requirements. Please note, we will always request the chip data to ensure we offer a compatible socket. For SMT sockets in general, E-tec Interconnect AG recommends the use of locating pegs, which can be soldered to the PCB for added mechanical strength.

Specifications contact type code 1030			
Application	Surface mouting	Force	25 gr
Mounting	SMT	Current rating	1.8 A
Bandwidth (GHz@-1dB)	2.8(6.6) GHz	Capacitance pF	0.62 pF
Contact resistance	<100mOhm	Inductance nH	1.97 nH
Chip contact tip shape	Single Point tip or Concave tip	Temperature range	-55°C to +150°C
PCB tip shape	SMT	Mating cycles	100 K

**How to order**

**QU # #### -1030 - ##### 95 #**

<p><b>Shape of tip</b></p> <p>U : Concave</p> <p><b>Options:</b></p> <p>P : Pointed</p>	<p><b>Nbr of contacts</b></p> <p>Depends on ballcount of chip</p>	<p><b>Contact type</b></p> <p>30 : Standard SMT – Dimension A = 0.80 mm</p>	<p><b>Plating</b></p> <p>95 : Tin / Gold</p> <p>Other on request</p>	<p><b>Option code</b> (see page 16-19)</p> <p>D : Dead bug</p> <p>U : Multi packages</p> <p>S : Custom opening slot</p> <p>L : Locating pegs</p> <p>H : Heatsink</p> <p>F : Fan + Heatsink</p> <p>P : Thermal drain pad</p> <p>W : Transparent lid</p> <p>I : Steel retention lid</p> <p>T : Torque tool fixture</p> <p>B : Aluminium retention lid</p> <p>G : Handling button</p>
<p><b>Retention frame type (Lid)</b> (see page 12-15)</p> <p>S : ScrewLock</p> <p>F : FastLock</p> <p>B : SpringLock</p> <p>H : Open Clamshell Alu (&lt;200 contacts)</p> <p>J : Clamshell Alu (&gt;200 contacts)</p> <p>L : Open Lever Clamshell Alu (&gt;200 contacts)</p>		<p>Q : Open QuickLock (&lt;200 contacts)</p> <p>D : QuickLock (&gt;200 contacts)</p> <p>M : Injection Molded ClamShell</p>		<p><b>Grid code / Config. code</b></p> <p>Will be given by the factory after receipt of the chip datasheet</p>



**Raised SMT soldering Test Socket**  
 For SOP / DSO / SOIC / QFP / xQFP, Flatpack Package  
**1.00 mm pitch** (from 1.00 mm up to 1.26 mm)

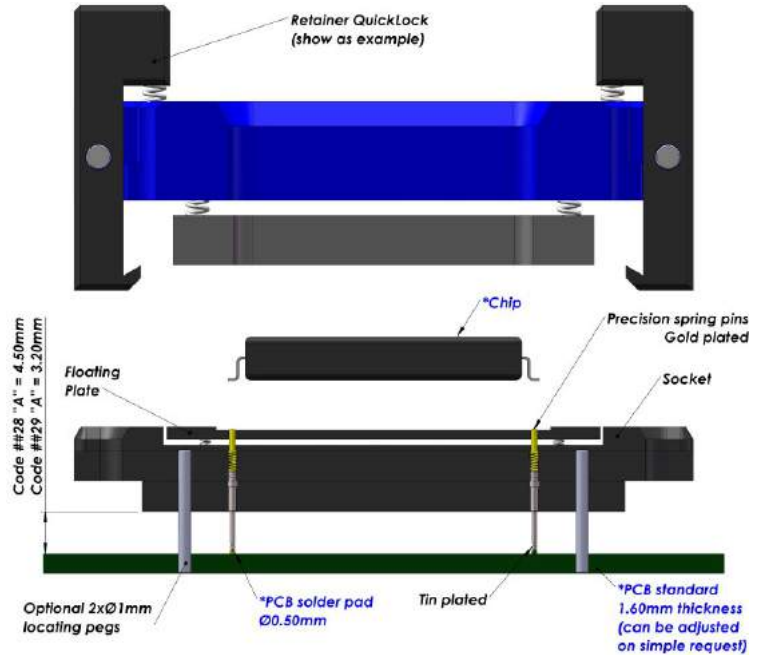
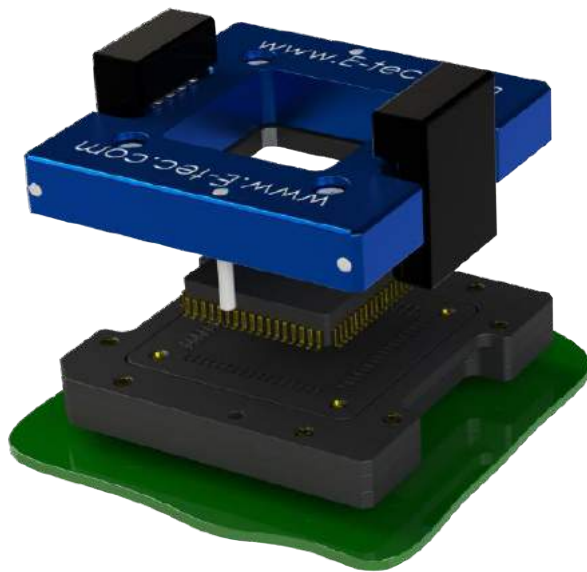
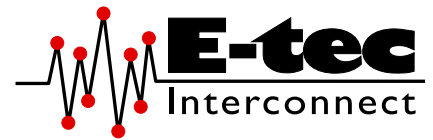

**E-tec Interconnect AG is the world leading Test socket manufacturer**

The Raised SMT socket lifts the socket above close-by components on PCB and uses the same footprint as your chip. Socket is simply placed and reflowed onto the PCB in the same way as the chip and it only requires a small amount of additional board space. Raised SMT sockets are available with all retention systems. We aim to solve your requirements. Please note, we will always request the chip data to ensure we offer a compatible socket. For Raised SMT sockets in general, E-tec Interconnect AG recommends the use of locating pegs, which can be soldered to the PCB for added mechanical strength.

Specifications contact type code 1029 & 1028			
Application	Surface mouting	Force	25 gr
Mounting	Raised SMT	Current rating	1.8 A
Bandwidth (GHz@-1dB)	na	Capacitance pF	na
Contact resistance	<100mOhm	Inductance nH	na
Chip contact tip shape	Single Point tip or Concave tip	Temperature range	-55°C to +150°C
PCB tip shape	Raised SMT	Mating cycles	100 K

**How to order**

**QU # #### -102# - ##### 95A #**

<p><b>Shape of tip</b></p> <p>U : Concave</p> <p><b>Options:</b></p> <p>P : Pointed</p>	<p><b>Nbr of contacts</b></p> <p>Depends on ballcount of chip</p>	<p><b>Contact type</b></p> <p>29 : Raised SMT – Dimension A = 3.20 mm</p> <p>28 : Special Raised SMT - Dim. A = 4.50 mm</p>	<p><b>Plating</b></p> <p>95A: Tin/Gold + Alignment plate</p> <p>Other on request</p>	<p><b>Option code</b> (see page 16-19)</p> <p>D : Dead bug</p> <p>U : Multi packages</p> <p>S : Custom opening slot</p> <p>L : Locating pegs</p> <p>H : Heatsink</p> <p>F : Fan + Heatsink</p> <p>P : Thermal drain pad</p> <p>W : Transparent lid</p> <p>I : Steel retention lid</p> <p>B : Aluminium retention lid</p> <p>T : Torque tool fixture</p> <p>G : Handling button</p>
<p><b>Retention frame type (Lid)</b> (see page 12-15)</p> <p>S : ScrewLock</p> <p>F : FastLock</p> <p>B : SpringLock</p> <p>H : Open Clamshell Alu (&lt;200 contacts)</p> <p>J : Clamshell Alu (&gt;200 contacts)</p> <p>L : Open Lever Clamshell Alu (&gt;200 contacts)</p>		<p><b>Grid code / Config. code</b></p> <p>Will be given by the factory after receipt of the chip datasheet</p>		
		<p><b>Q : Open QuickLock (&lt;200 contacts)</b></p> <p><b>D : QuickLock (&gt;200 contacts)</b></p> <p><b>M : Injection Molded ClamShell</b></p>		



# Probe Pin Solderless Compression Test Socket

For SOP / DSO / SOIC / QFP / xQFP Package

1.00 mm pitch (from 1.00 mm to 1.26 mm)

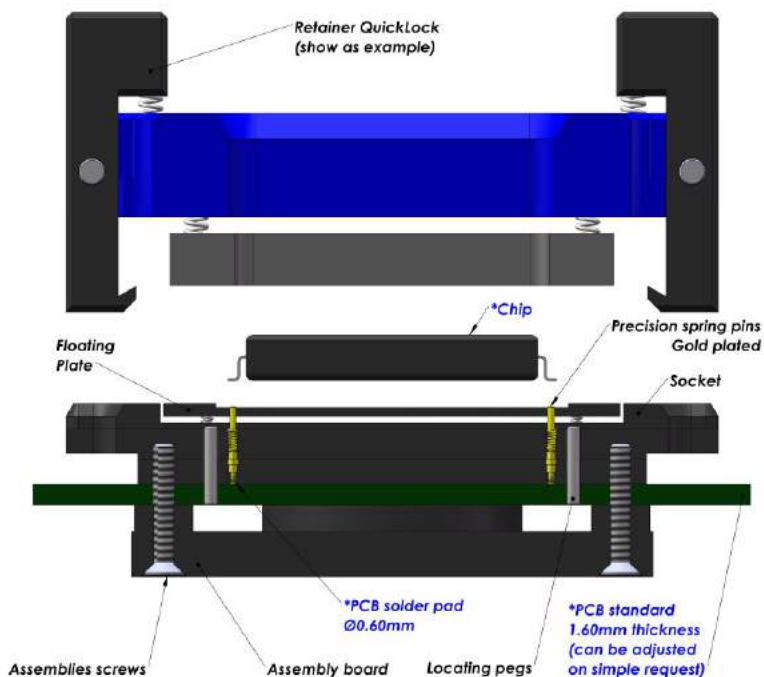
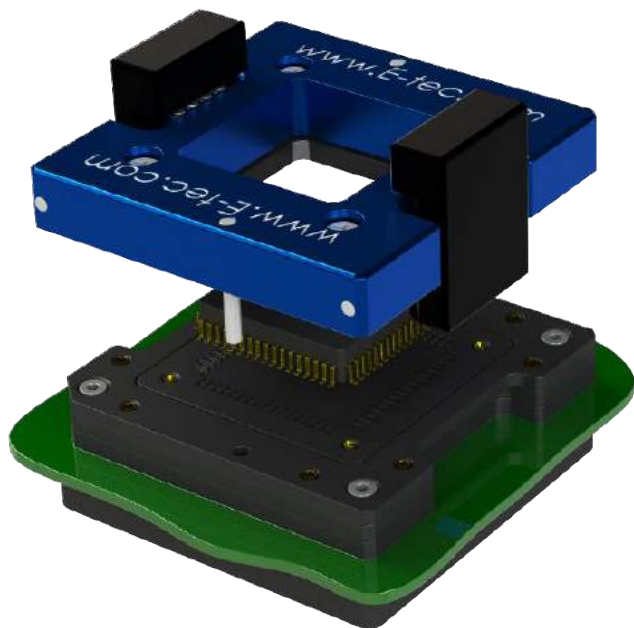
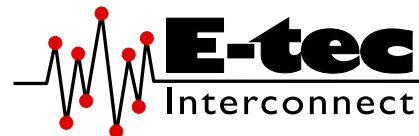

**E-tec Interconnect AG is the world leading Test socket manufacturer**

Probe Pin (Pogo) Solderless compression Test Sockets type are available for any chip size and pitch and are attached with 2, 4 or 8 screws to the PCB. The assembly board ensures perfect coplanarity of the socket. Contact reliability is guaranteed with spring loaded gold plated contacts, which are pressed onto gold plated PCB pads. Probe Pin (Pogo) Solderless compression type sockets are available with all retention systems. We aim to solve your requirements. Please note, we will always request the chip data to ensure we offer a compatible socket.

Contacts Specifications						
Contact type code	1090	1091	1092	1093	1094	1098
Application	Standard	Long Live	High Frequency	High Power	Frequency	Frequency
Mounting	Solderless	Solderless	Solderless	Solderless	Solderless	Solderless
Bandwidth (GHz@-1dB)	3 GHz	11 GHz	31 GHz	10 GHz	9.4 GHz	30.3 GHz
Contact resistance	<100 mOhm	45 mOhm	100 mOhm	30 mOhm	25 mOhm	25 mOhm
Chip contact tip shape	Single Point tip Concave tip	Crown tip	Single Point tip	Round tip	Single Point tip	Single Point tip
PCB tip shape	Single Point tip	Single Point tip	Single Point tip	Single Point tip	Spring	Spring
Force	25 gr	35 gr	33 gr	30 gr	25 gr	25 gr
Current rating	1.8 A	3 A	1 A	4 A	5 A	2.6 A
Capacitance pF	<1 pF	0.55 pF	0.39 pF	0.19 pF	0.85 pF	0.54 pF
Inductance nH	<2 nH	0.76 nH	1.01 nH	0.93 nH	1.36 nH	1.70 nH
Impedance Ohms	45 Ω	36 Ω	46 Ω	38 Ω	35 Ω	59.9 Ω
Temperature range	-55°C to +150°C	-40°C to +120°C	-50°C to +120°C	-55°C to +180°C	-55°C to +150°C	-55°C to +150°C
Mating cycles	100 K	300 K	100 K	125 K	100 K	100 K

More on the next page





# Probe Pin Solderless Compression Test Socket

For SOP / DSO / SOIC / QFP / xQFP Package

1.00 mm pitch (from 1.00 mm to 1.26 mm)

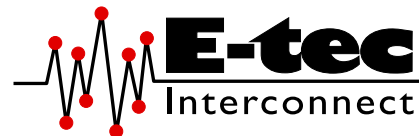

## Standard assembly boards

Small Chip size



Medium Chip size

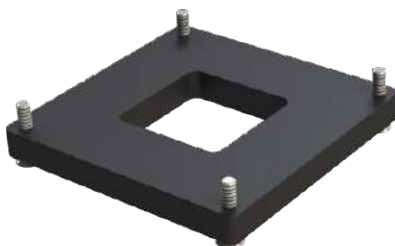

Large Chip size

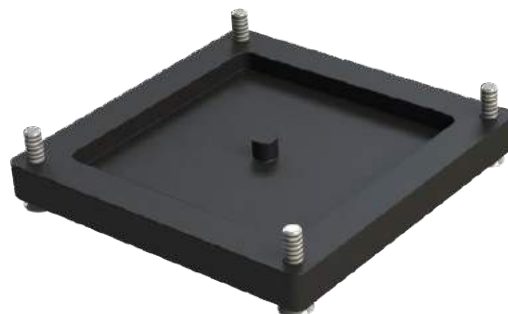

## Custom assembly boards

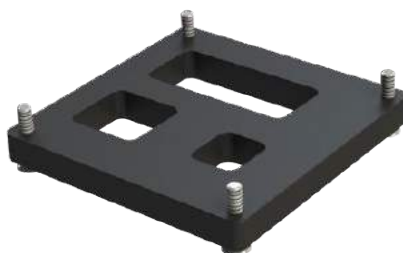
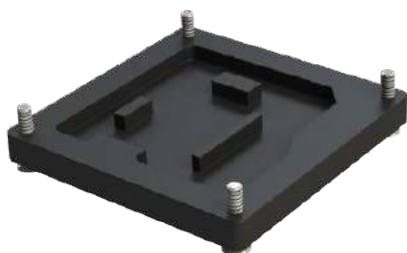

## How to order

**QU # # # # -109# - # # # # # 55L #**

**Shape of tip**

**U** : Concave

**Options:**

**P** : Pointed

**Nbr of contacts**

Depends on ballcount of chip

**Contact type**

**91 to 98** : See "Contacts specification" chart

**90** : Standard solderless compression style

**9M** : Special mixed contact style

**Plating**

**55L**: Gold + Locating pegs

Other on request

**Option code** (see page 16-19)

**D** : Dead bug

**M** : Multi frames

**U** : Multi packages

**S** : Custom opening slot

**H** : Heatsink

**F** : Fan + Heatsink

**P** : Thermal drain pad

**W** : Transparent lid

**I** : Steel retention lid

**B** : Aluminium retention lid

**T** : Torque tool fixture

**G** : Handling button

**Retention frame type (Lid)** (see page 12-15)

**S** : ScrewLock

**F** : FastLock

**B** : SpringLock

**H** : Open Clamshell Alu (<200 contacts)

**J** : Clamshell Alu (>200 contacts)

**L** : Open Lever Clamshell Alu (>200 contacts)

**Q** : Open QuickLock (<200 contacts)

**D** : QuickLock (>200 contacts)

**M** : Injection Molded ClamShell

**Grid code / Config. code**

Will be given by the factory after receipt of the chip datasheet





# Through-hole (THT) soldering Test Socket

For SOP / DSO / SOIC / QFP / xQFP / Flatpack Package  
**1.27 mm pitch** (from 1.27 mm upwards)

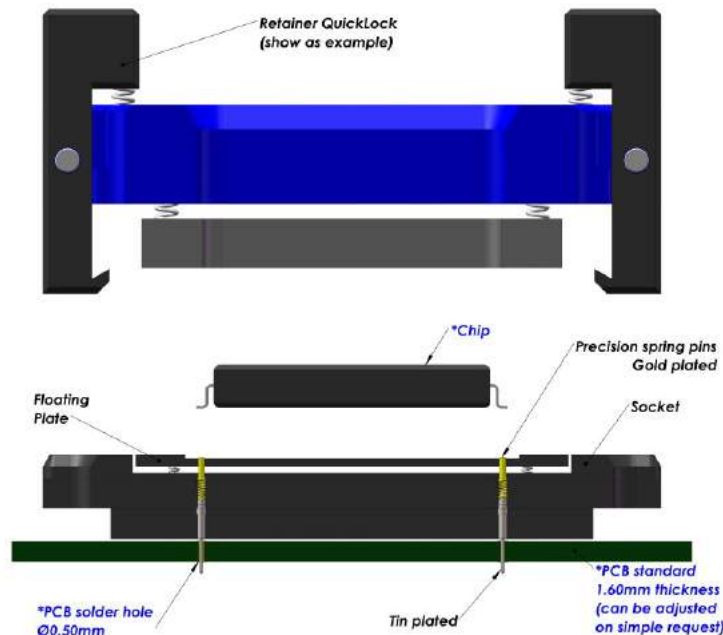
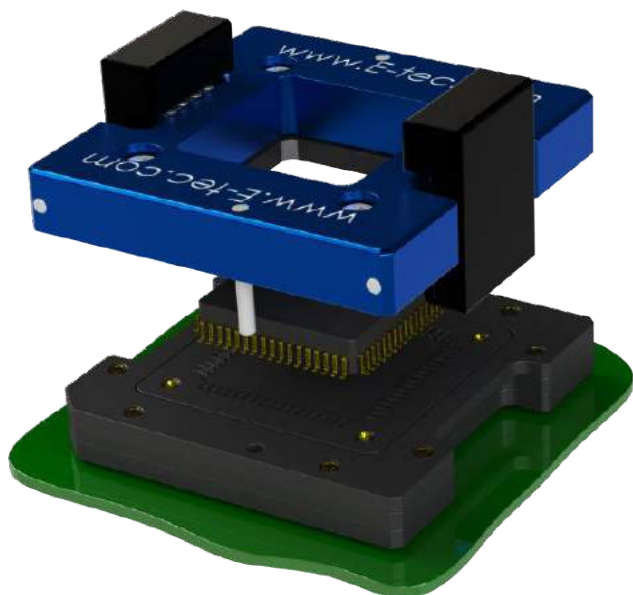
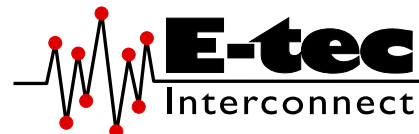

**E-tec Interconnect AG is the world leading Test socket manufacturer**

The Through-hole socket uses the same footprint as your chip. Socket is simply placed and wave soldered onto the PCB in the same way as the chip and it only requires a small amount of additional board space. Through-hole sockets are available with all retention systems. Please note, we will always request the chip data to ensure we offer a compatible socket.

Specifications contact type code 1270			
<b>Application</b>	Through-hole technology	<b>Force</b>	25 gr
<b>Mounting</b>	THT	<b>Current rating</b>	2.2 A
<b>Bandwidth (GHz@-1dB)</b>	3 GHz	<b>Capacitance pF</b>	< 1 pF
<b>Contact resistance</b>	<100mOhm	<b>Inductance nH</b>	< 2 nH
<b>Chip contact tip shape</b>	Single Point tip or Concave tip	<b>Temperature range</b>	-55°C to +150°C
<b>PCB tip shape</b>	Through-hole	<b>Mating cycles</b>	100 K

## How to order

**QU # # # # # -127# - # # # # # # #5 #**

### Shape of tip

**U** : Concave

#### Options:

**P** : Pointed

### Nbr of contacts

Depends on ballcount of chip

### Contact type

**70** : Standard THT

**72** : Special THT to plug into MGS adapters

### Plating

**95**: Tin / Gold

**55**: Gold / Gold

Other on request

### Option code (see page 16-19)

**D** : Dead bug

**M** : Multi frames

**U** : Multi packages

**S** : Custom opening slot

**L** : Locating pegs

**A** : Alignment plate

**H** : Heatsink

**F** : Fan + Heatsink

**P** : Thermal drain pad

**W** : Transparent lid

**I** : Steel retention lid

**B** : Aluminium retention lid

**T** : Torque tool fixture

**G** : Handling button

### Retention frame type (Lid) (see page 12-15)

**S** : ScrewLock

**F** : FastLock

**B** : SpringLock

**H** : Open Clamshell Alu (<200 contacts)

**J** : Clamshell Alu (>200 contacts)

**L** : Open Lever Clamshell Alu (>200 contacts)

**Q** : Open QuickLock (<200 contacts)

**D** : QuickLock (>200 contacts)

**M** : Injection Molded ClamShell

### Grid code / Config. code

Will be given by the factory after receipt of the chip datasheet



# Standard SMT soldering Test Socket

For SOP / DSO / SOIC / QFP / xQFP / Flatpack Package  
**1.27 mm pitch** (from 1.27 upwards)

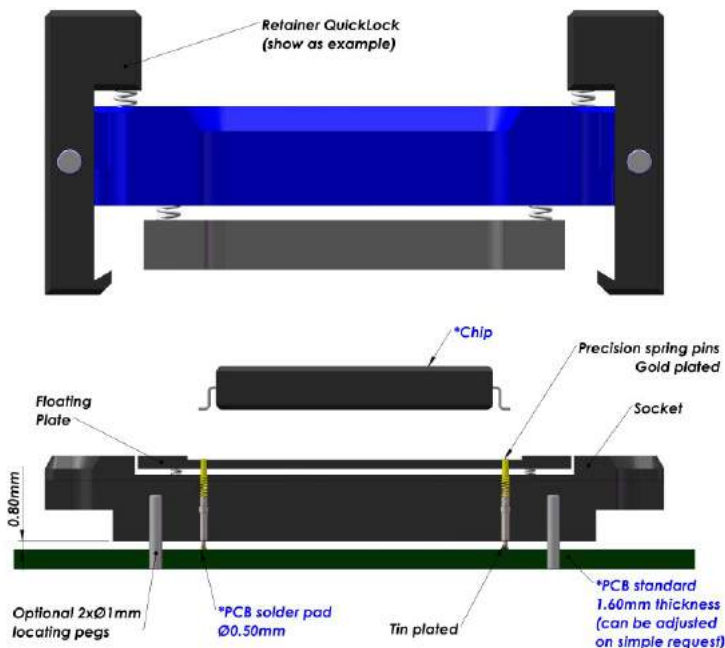
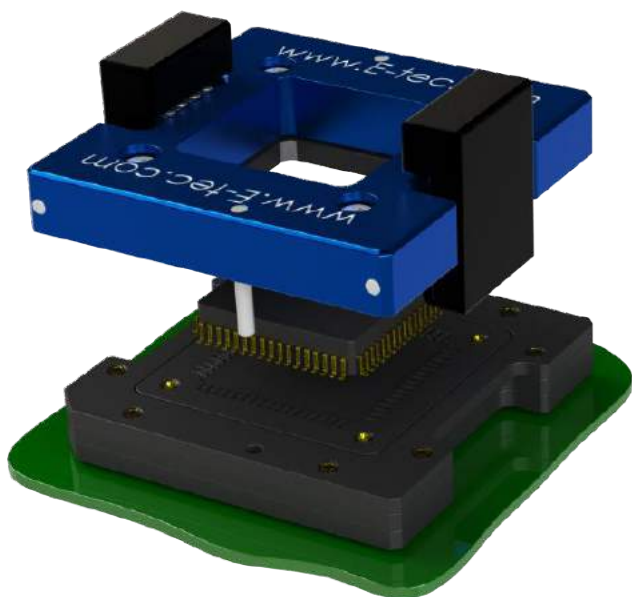
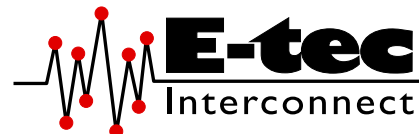

## E-tec Interconnect AG is the world leading Test socket manufacturer

The SMT socket uses the same footprint as your chip. Socket is simply placed and reflowed onto the PCB in the same way as the chip and it only requires a small amount of additional board space. SMT type sockets are available with all retention systems. We aim to solve your requirements. Please note, we will always request the chip data to ensure we offer a compatible socket. For SMT sockets in general, E-tec Interconnect AG recommends the use of locating pegs, which can be soldered to the PCB for added mechanical strength

Specifications contact type code 1230			
Application	Surface mouting	Force	25 gr
Mounting	SMT	Current rating	2.2 A
Bandwidth (GHz@-1dB)	3 GHz	Capacitance pF	< 1 pF
Contact resistance	<100mOhm	Inductance nH	< 2 nH
Chip contact tip shape	Single Point tip or Concave tip	Temperature range	-55°C to +150°C
PCB tip shape	SMT	Mating cycles	100 K

## How to order

**QU # #### -1230 - ##### 95 #**

<p><b>Shape of tip</b></p> <p>U : Concave</p> <p><b>Options:</b></p> <p>P : Pointed</p>	<p><b>Nbr of contacts</b></p> <p>Depends on ballcount of chip</p>	<p><b>Contact type</b></p> <p>30 : Standard SMT – Dimension A = 0.80 mm</p>	<p><b>Plating</b></p> <p>95 : Tin / Gold</p> <p>Other on request</p>	<p><b>Option code</b> (see page 16-19)</p> <p>D : Dead bug</p> <p>U : Multi packages</p> <p>S : Custom opening slot</p> <p>L : Locating pegs</p> <p>H : Heatsink</p> <p>F : Fan + Heatsink</p> <p>P : Thermal drain pad</p> <p>W : Transparent lid</p> <p>I : Steel retention lid</p> <p>T : Torque tool fixture</p> <p>B : Aluminium retention lid</p> <p>G : Handling button</p>
<p><b>Retention frame type (Lid)</b> (see page 12-15)</p> <p>S : ScrewLock</p> <p>F : FastLock</p> <p>B : SpringLock</p> <p>H : Open Clamshell Alu (&lt;200 contacts)</p> <p>J : Clamshell Alu (&gt;200 contacts)</p> <p>L : Open Lever Clamshell Alu (&gt;200 contacts)</p>		<p><b>Grid code / Config. code</b></p> <p>Will be given by the factory after receipt of the chip datasheet</p>		
		<p><b>Q</b> : Open QuickLock (&lt;200 contacts)</p> <p><b>D</b> : QuickLock (&gt;200 contacts)</p> <p><b>M</b> : Injection Molded ClamShell</p>		



**Raised SMT soldering Test Socket**  
 For SOP / DSO / SOIC / QFP / xQFP, Flatpack Package  
**1.27 mm pitch** (from 1.27 mm upwards)

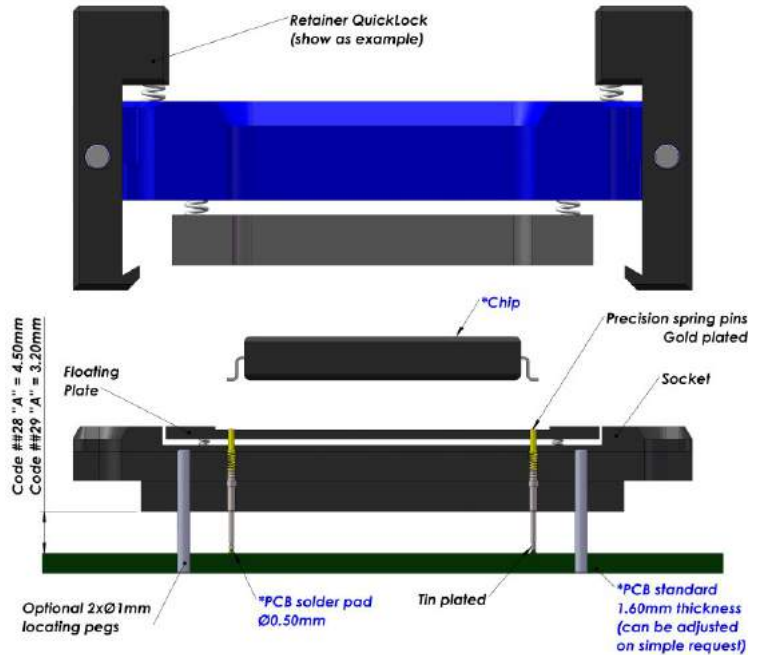
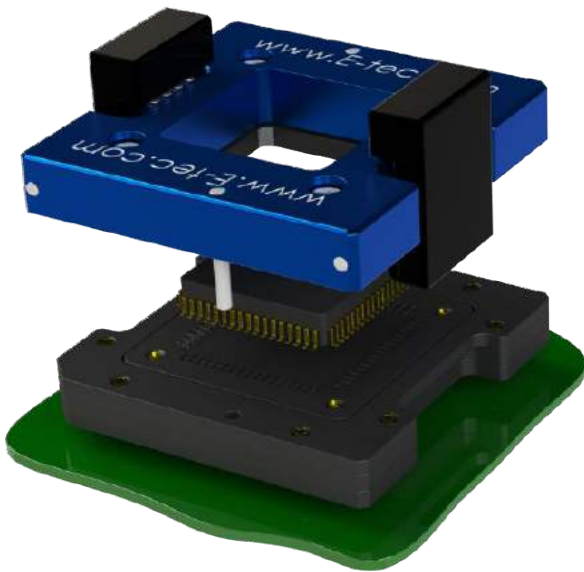
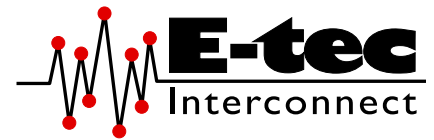

**E-tec Interconnect AG is the world leading Test socket manufacturer**

The Raised SMT socket lifts the socket above close-by components on PCB and uses the same footprint as your chip. Socket is simply placed and reflowed onto the PCB in the same way as the chip and it only requires a small amount of additional board space. Raised SMT sockets are available with all retention systems. We aim to solve your requirements. Please note, we will always request the chip data to ensure we offer a compatible socket. For Raised SMT sockets in general, E-tec Interconnect AG recommends the use of locating pegs, which can be soldered to the PCB for added mechanical strength.

Specifications contact type code 1229			
Application	Surface mouting	Force	25 gr
Mounting	Raised SMT	Current rating	2.2 A
Bandwidth (GHz@-1dB)	na	Capacitance pF	na
Contact resistance	<100mOhm	Inductance nH	na
Chip contact tip shape	Single Point tip or Concave tip	Temperature range	-55°C to +150°C
PCB tip shape	Raised SMT	Mating cycles	100 K

**How to order**

**QU # #### -1229 - ##### 95A #**

<p><b>Shape of tip</b></p> <p>U : Concave</p> <p><b>Options:</b></p> <p>P : Pointed</p>	<p><b>Nbr of contacts</b></p> <p>Depends on ballcount of chip</p>	<p><b>Contact type</b></p> <p>29 : Raised SMT – Dimension A = 3.20 mm</p> <p>28 : Special Raised SMT - Dim. A = 4.50 mm</p>	<p><b>Plating</b></p> <p>95A: Tin/Gold + Alignment plate</p> <p>Other on request</p>	<p><b>Option code</b> (see page 16-19)</p> <p>D : Dead bug</p> <p>U : Multi packages</p> <p>S : Custom opening slot</p> <p>L : Locating pegs</p> <p>H : Heatsink</p> <p>F : Fan + Heatsink</p> <p>P : Thermal drain pad</p> <p>W : Transparent lid</p> <p>I : Steel retention lid</p> <p>B : Aluminium retention lid</p> <p>T : Torque tool fixture</p> <p>G : Handling button</p>
<p><b>Retention frame type (Lid)</b> (see page 12-15)</p> <p>S : ScrewLock</p> <p>F : FastLock</p> <p>B : SpringLock</p> <p>H : Open Clamshell Alu (&lt;200 contacts)</p> <p>J : Clamshell Alu (&gt;200 contacts)</p> <p>L : Open Lever Clamshell Alu (&gt;200 contacts)</p>		<p><b>Grid code / Config. code</b></p> <p>Will be given by the factory after receipt of the chip datasheet</p>		
		<p><b>Q</b> : Open QuickLock (&lt;200 contacts)</p> <p><b>D</b> : QuickLock (&gt;200 contacts)</p> <p><b>M</b> : Injection Molded ClamShell</p>		





# Probe Pin Solderless Compression Test Socket

For SOP / DSO / SOIC / QFP / xQFP Package

1.27 mm pitch (from 1.27 mm upwards)

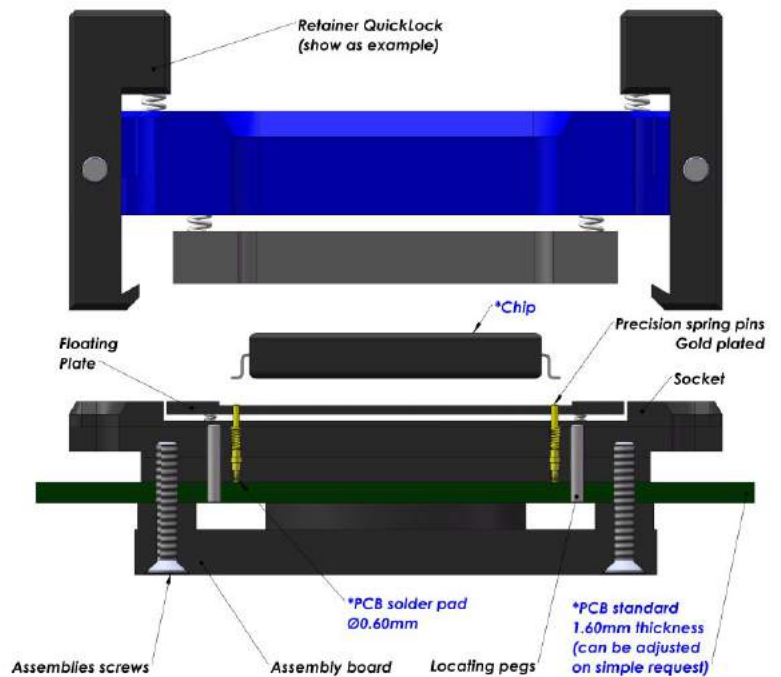
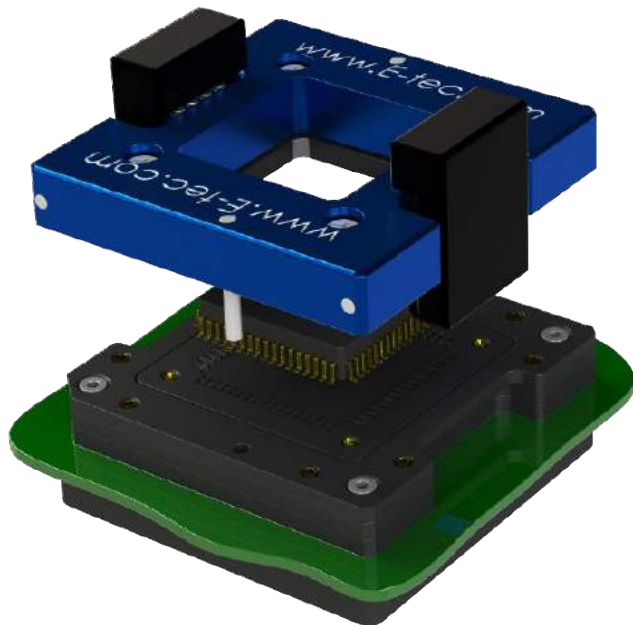

**E-tec Interconnect AG is the world leading Test socket manufacturer**

Probe Pin (Pogo) Solderless compression Test Sockets type are available for any chip size and pitch and are attached with 2, 4 or 8 screws to the PCB. The assembly board ensures perfect coplanarity of the socket. Contact reliability is guaranteed with spring loaded gold plated contacts, which are pressed onto gold plated PCB pads. Probe Pin (Pogo) Solderless compression type sockets are available with all retention systems. We aim to solve your requirements. Please note, we will always request the chip data to ensure we offer a compatible socket.

Contacts Specifications				
Contact type code	1290	1291	1294	1298
Application	Standard	High Frequency + Long Live	Frequency	Frequency
Mounting	Solderless	Solderless	Solderless	Solderless
Bandwidth (GHz@-1dB)	3 GHz	37.5 GHz	13.3 GHz	23.7 GHz
Contact resistance	<100 mOhm	45 mOhm	25 mOhm	25 mOhm
Chip contact tip shape	Single Point tip Concave tip	Crown tip	Single Point tip	Single Point tip
PCB tip shape	Single Point tip	Single Point tip	Spring	Spring
Force	25 gr	35 gr	25 gr	25 gr
Current rating	2.2 A	3 A	5 A	2.6 A
Capacitance pF	<1 pF	0.43 pF	0.76 pF	0.50 pF
Inductance nH	<2 nH	0.82 nH	1.73 nH	2.03 nH
Impedance Ohms	48 Ω	41 Ω	42.8 Ω	67.5 Ω
Temperature range	-55°C to +150°C	-40°C to +120°C	-55°C to +150°C	-55°C to +150°C
Mating cycles	100 K	300 K	100 K	100 K

More on the next page



# Probe Pin Solderless Compression Test Socket

For SOP / DSO / SOIC / QFP / xQFP Package

1.27 mm pitch (from 1.27 mm upwards)

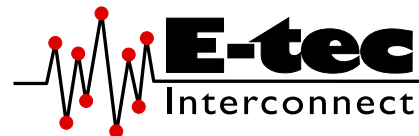

## Standard assembly boards

Small Chip size



Medium Chip size

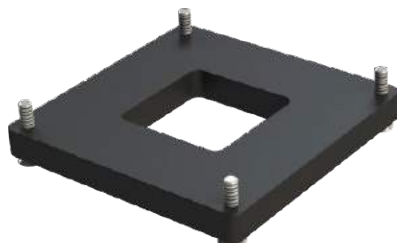

Large Chip size

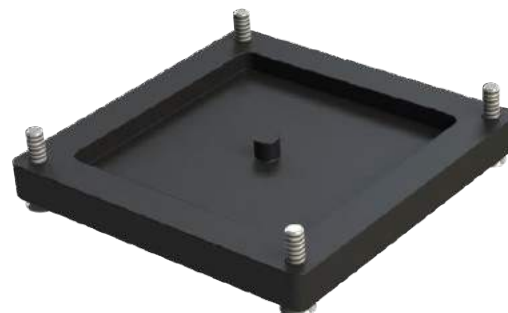

## Custom assembly boards

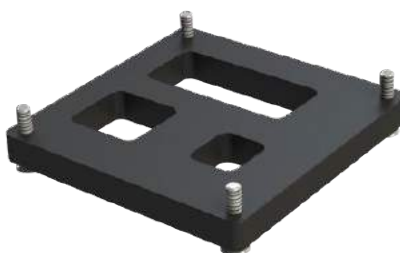
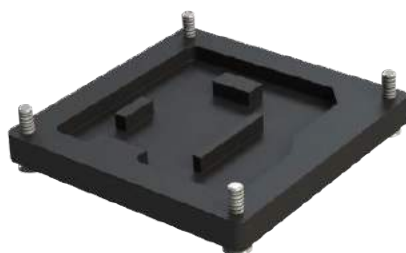

## How to order

**QU # # # # -129# - # # # # # 55L #**

**Shape of tip**  
**U** : Concave  
**Options:**  
**P** : Pointed

**Nbr of contacts**  
 Depends on ballcount of chip

**Contact type**  
**91 to 98** : See "Contacts specification" chart  
**90** : Standard solderless compression style  
**9M** : Special mixed contact style

**Plating**  
**55L**: Gold + Locating pegs  
 Other on request

**Option code** (see page 16-19)  
**D** : Dead bug  
**M** : Multi frames  
**U** : Multi packages  
**S** : Custom opening slot

**Retention frame type (Lid)** (see page 12-15)

<b>S</b> : ScrewLock	<b>Q</b> : Open QuickLock (<200 contacts)
<b>F</b> : FastLock	<b>D</b> : QuickLock (>200 contacts)
<b>B</b> : SpringLock	<b>M</b> : Injection Molded ClamShell
<b>H</b> : Open Clamshell Alu (<200 contacts)	
<b>J</b> : Clamshell Alu (>200 contacts)	
<b>L</b> : Open Lever Clamshell Alu (>200 contacts)	

**Grid code / Config. code**  
 Will be given by the factory after receipt of the chip datasheet

**H** : Heatsink  
**F** : Fan + Heatsink  
**P** : Thermal drain pad  
**W** : Transparent lid  
**I** : Steel retention lid  
**B** : Aluminium retention lid  
**T** : Torque tool fixture  
**G** : Handling button



## Why need an adapter?

In certain cases, you are not able to place any test socket on your board, because:

- Its density is too high
- It was not designed to accommodate any test socket.
- The package dimensions or layout have changed.
- Etc...

So E-tec Interconnect has developed a mounting solution with adapter for Test Sockets. As usual, we propose a full range of mounting, to help customer to find the right solution for his own issue.

### ABG series: Male adapter

The E-tec Interconnect BGA Adapter System comprises two elements, the BGA solder adapter onto which the BGA chip is soldered (converting the BGA chip to a PGA, **ABG** series ), and the MiniGrid Socket which is soldered to the PCB. The solder adapter can then be plugged into the **MiniGrid Socket** (refer to **MGS** series).

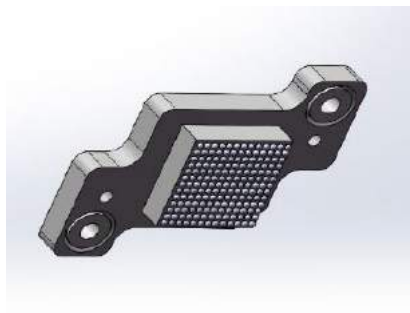
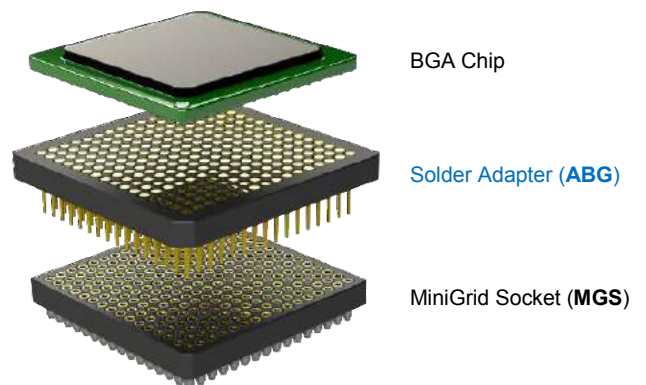

The pitch becomes smaller and smaller. So, E-tec Interconnect modified the ABG series and reduce the pitch to 0.4 mm. Its design team also enhanced the functionality to incorporate from now on our Solderless Compression Test Socket as well.

Thanks to this progress, E-tec Interconnect continues to respond to your constant new requests.

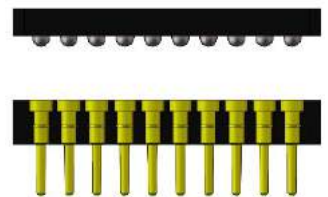

Standard SMT pin, raised SMT pin and SMT solderballs are available in both functions.

E-tec Interconnect offers any pin-out, configuration and grid size.

Special terminal designs are possible on request



## MGS series: Female adapter

The E-tec Interconnect **MiniGrid Socket** adapter is soldered to the target board and is designed to accept the BGA solder **ABG** adapter (where the chip is soldered to the adapter board) or any kind of miniPGA or PGI.

As an alternative, this MiniGrid Socket is also designed to accept the “true” through hole BGA Sockets (where the chips can be socketed without soldering).

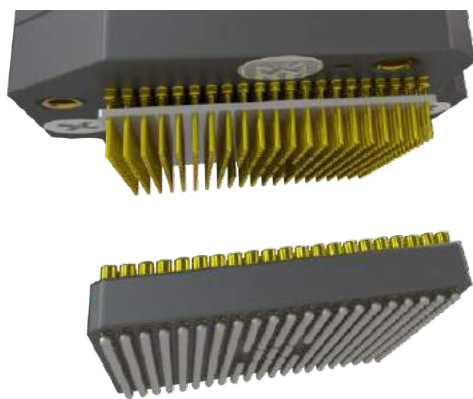
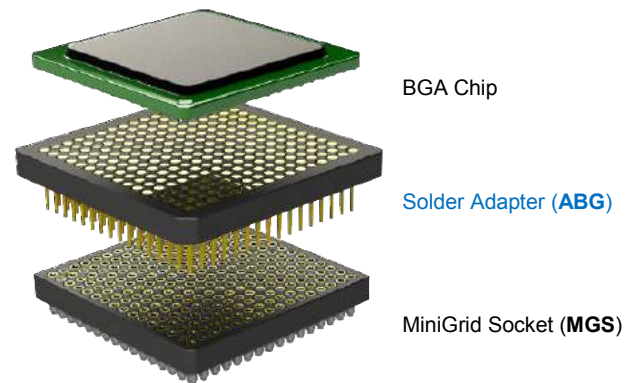

**MiniGrid Socket** adapter allows E-tec Interconnect Test Sockets to be inserted.

The SMT adapter is available either with solder ball or with solid pin terminals. This SMT adapter emulates the chip’s BGA footprint and is easily installed using standard flux and reflow techniques. The solder ball adapters have the same solder ball types as the IC’s they are emulating. You can combine the SMT foot with any of the E-tec Interconnect socket styles shown in the Test Socket section. The corresponding male BGA socket, through hole type, is plugged into the adapter.

E-tec Interconnect offer any pin-out, configuration and grid size for pitch 0.8mm, 1.00mm and 1.27mm, any pin-out, configuration and grid size. Other pitch and special terminal designs are possible on request.

E-tec Interconnect prides itself on being a leader in the Test Interconnect industry and working with our customers to design the highest performance, top quality testing solutions possible.

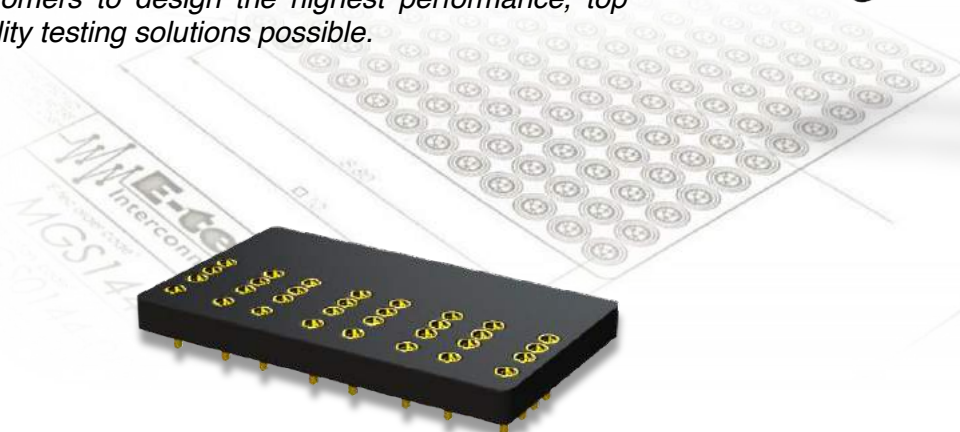
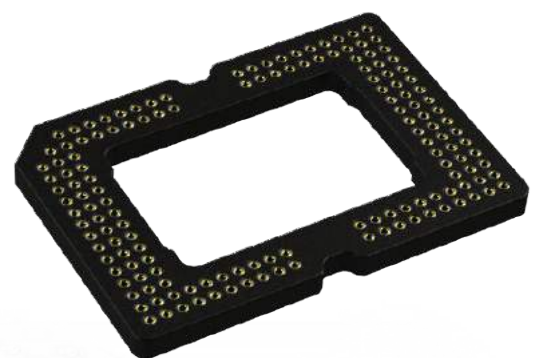

Pitch	Adapter series				
	MGS THT	MGS SMT Solderpin	MGS SMT Solderballs	ABG SMT Solderpin	ABG SMT Solderballs
0.4 mm	no	no	no	yes	yes
0.5 mm	no	no	no	yes	yes
0.8 mm	yes	yes	yes	yes	yes
1.0 mm	yes	yes	yes	yes	yes
1.27 mm	yes	yes	yes	yes	yes

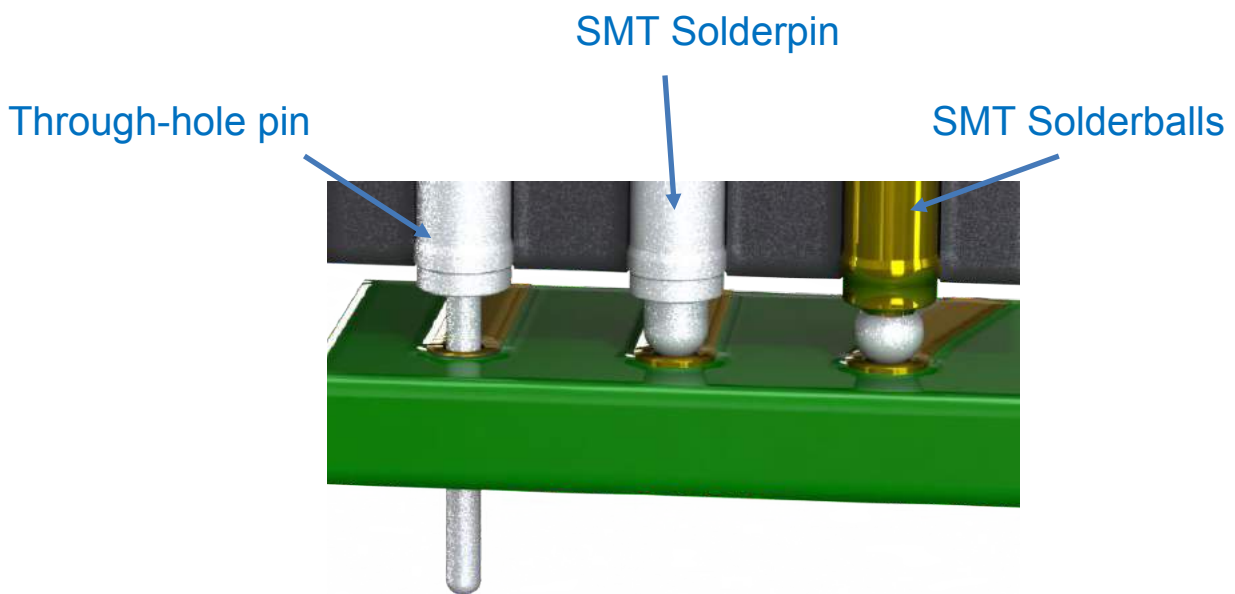



### ABG adapter to be plug into MGS adapter

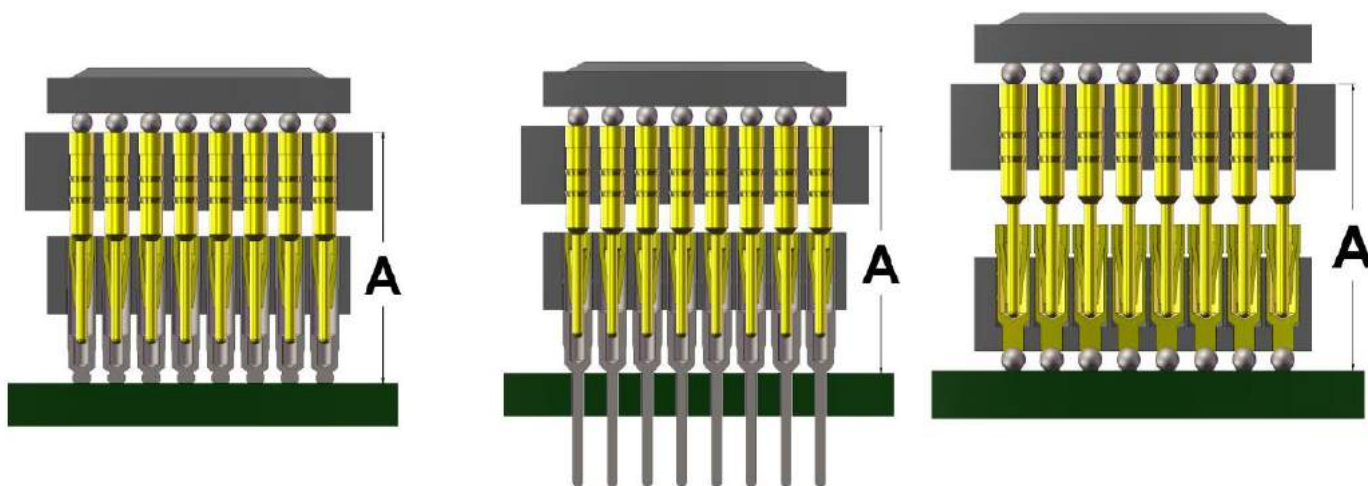
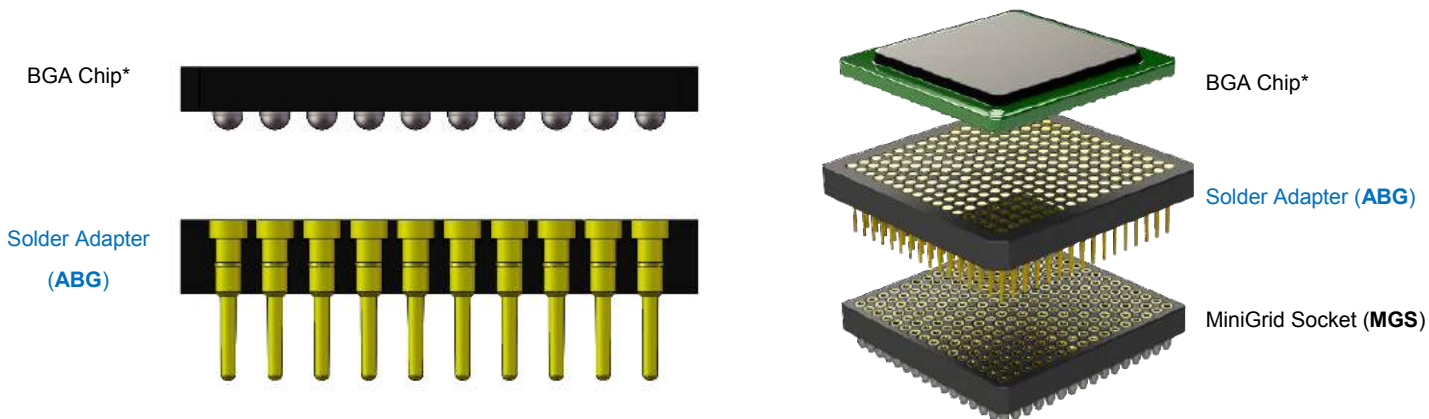

**Dimension A**

Pitch 1.27 mm : 5.4 mm  
 Pitch 1.00 mm : 5.9 mm  
 Pitch 0.80 mm : 5.9 mm

**Dimension A**

Pitch 1.27 mm : 5.2 mm  
 Pitch 1.00 mm : 5.7 mm  
 Pitch 0.80 mm : 5.7 mm

**Dimension A**

Pitch 1.27 mm : 5.6 mm  
 Pitch 1.00 mm : 5.6 mm  
 Pitch 0.80 mm : 5.7 mm

#### Specifications

<b>Terminal Type</b> 116, 158, 168 & 175	<b>Material</b> Contact: CuZn Solderball: SAC305	<b>Plating</b> Au over Ni over Cu	<b>Adapter</b> Material: Polyepoxy or other high temp mat.	<b>Others</b> Operating Temperature : -55°C to +125°C Processing Temperature : +260°C for 60 sec.
---	--	--------------------------------------	---	---

### How to order

**ABG ### - ### - ### 55 ##**

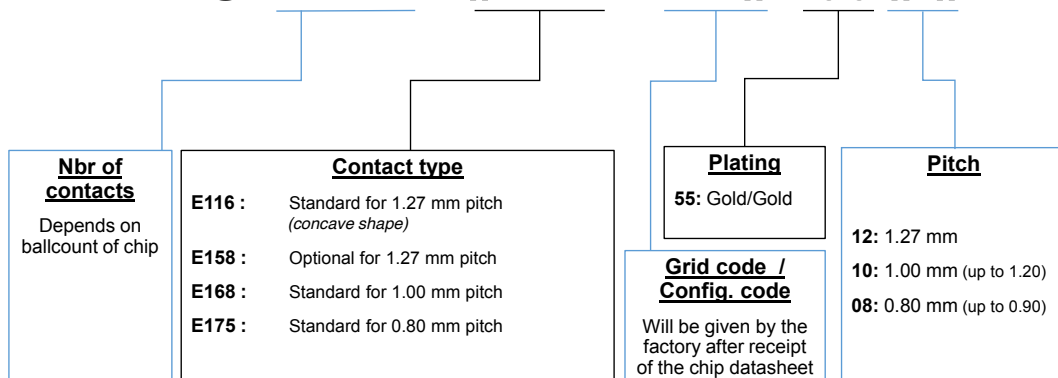

**ABG adapter to be soldered onto board**

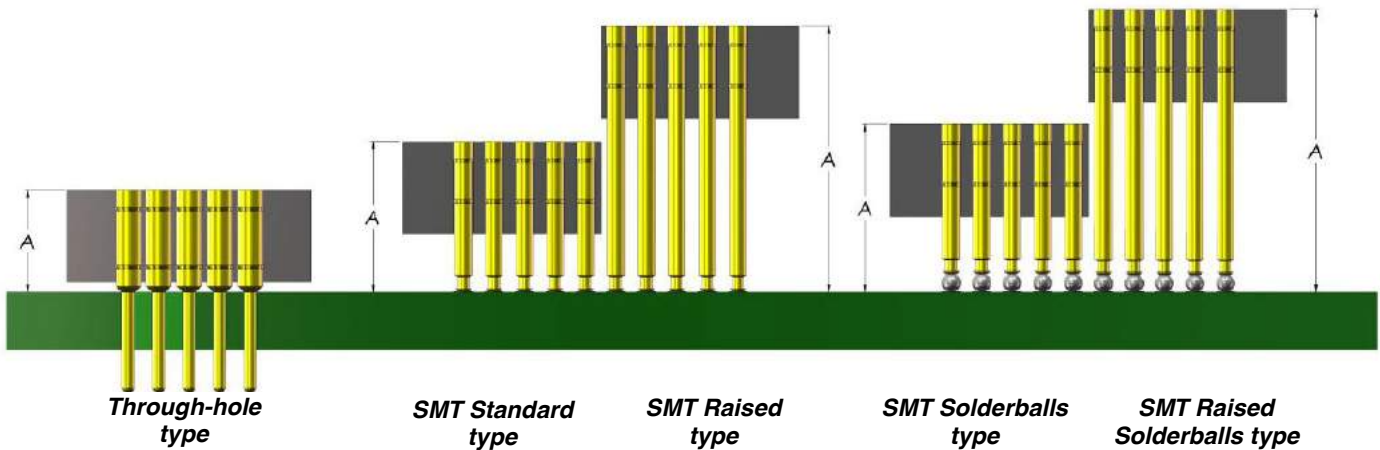
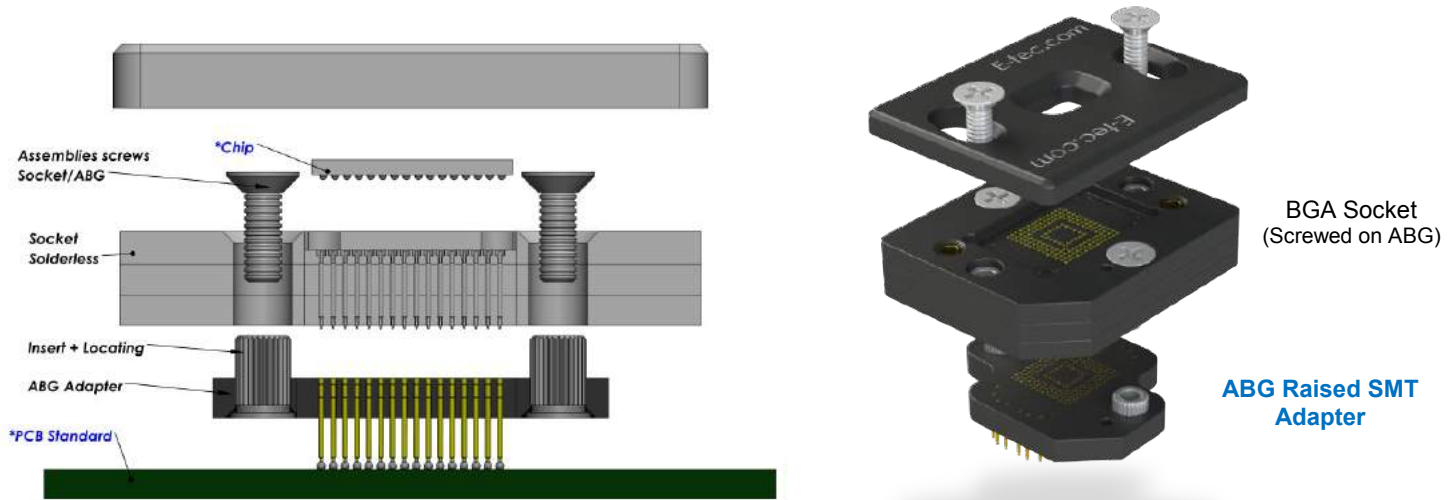

Specifications				
<b>Terminal Type</b> 116, 158, 168, 175, 420, 406, & 437	<b>Material</b> Contact : CuZn Solderball : SAC305	<b>Plating</b> Au over Ni over Cu	<b>Adapter</b> Material: Polyepoxy or other high temp mat.	<b>Others</b> Operating Temperature : -55°C to +125°C Processing Temperature : +260°C for 60 sec.

**How to order**

**ABG ### - ### - ### # 5 ##**

<b>Nbr of contacts</b> Depends on ballcount of chip	<b>Contact type</b> E116 : Through-hole for 1.27 mm pitch (concave) A=2.0mm E158 : Through-hole Optional for 1.27 mm pitch A=2.0 mm E168 : Through-hole for 1.00 mm pitch A= 2.5 mm E175 : Through-hole for 0.80 mm pitch A= 2.5 mm E420 : Through-hole for 0.60 mm pitch A= 1.5 mm E406 : SMT 0.40 / 0.50 / 0.60 mm pitch A= 2.8 mm E437 : Raised SMT 0.40 / 0.50 / 0.60 mm pitch A= 4.7 mm SB406 : SMT Solderballs 0.40 / 0.50 / 0.60 mm pitch A= 2.8 mm SB437 : Raised SMT Solderballs 0.40 / 0.50 / 0.60 mm A= 4.7 mm	<b>Plating</b> 55: Gold/Gold For Solderballs only : 95: Tin/Gold 05: PbTin/Gold	<b>Pitch</b> 12: 1.27 mm 10: 1.0 mm (up to 1.26) 08: 0.8 mm (up to 0.99) 07: 0.70 mm (up to 0.79) 06: 0.60 mm (up to 0.69) 05: 0.50 mm (up to 0.59) 04: 0.40 mm (up to 0.49)
	<b>Grid code / Config. code</b> Will be given by the factory after receipt of the chip datasheet		

# SMT / THT MGS adapter series

From 0.8 up to 1.27 mm pitch

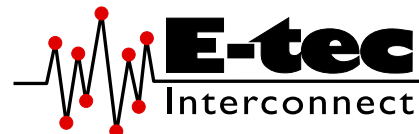

The E-tec Interconnect MiniGrid Socket is soldered to the target board and is designed to accept the BGA Solder Adapter (where the chip is soldered to the adapter board). As an alternative, this MiniGrid Socket is also designed to accept Test Sockets.

E-tec offers any pin-out, configuration and grid size. Special terminal designs are possible on request.

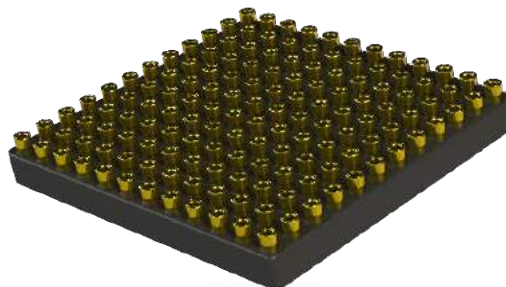

**SMT Standard type**



**Through hole type (THT)**

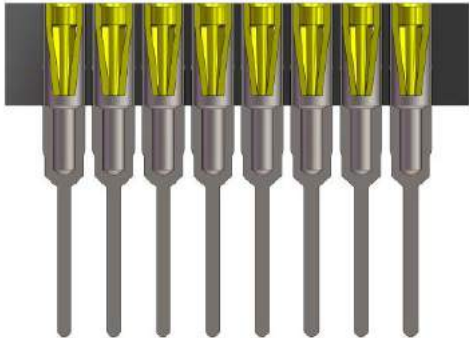

**Terminal styles**

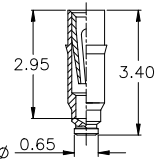
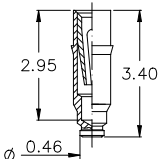
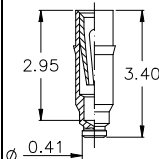
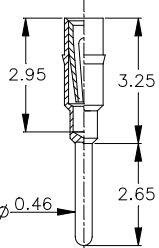
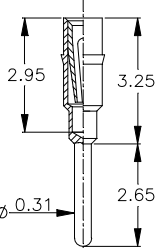
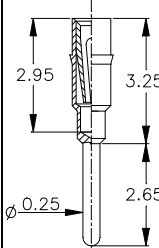
 <p style="text-align: center;"><i>SMT Terminal Type 119 if 1,27 ; 1,50 &amp; 2,00mm pitch</i></p>	 <p style="text-align: center;"><i>SMT Terminal Type 167 if 1,00mm pitch</i></p>	 <p style="text-align: center;"><i>SMT Terminal Type 169 if 0,80mm pitch</i></p>
 <p style="text-align: center;"><i>THT Terminal Type 117 if 1,27 ; 1,50 &amp; 2,00mm pitch</i></p>	 <p style="text-align: center;"><i>THT Terminal Type 172 if 1,00mm pitch</i></p>	 <p style="text-align: center;"><i>THT Terminal Type 174 if 0,80mm pitch</i></p>

### Specifications

<b>Terminal Type</b> 117, 119, 167, 169, 172, 174	<b>Material</b> <b>Terminal</b> : CuZn <b>Contact clip</b> : BeCu	<b>Plating</b> Sn over Ni over Cu Au over Ni over Cu	<b>Socket</b> <b>Material:</b> Polyepoxy or other high temp mat.	<b>Others</b> <b>Operating Temperature</b> : -55°C to +125°C <b>Processing Temperature</b> : 260°C for 60 sec.
--	---	--	---	--

### How to order

## MGS #### - E### - ### #5##

<p style="text-align: center;"><b><u>Nbr of contacts</u></b></p> <p style="text-align: center;">Depends on ballcount of chip</p>	<p style="text-align: center;"><b><u>Contact type</u></b></p> <p>E117 : THT 1.27 / 1.50 / 2.00 mm pitch</p> <p>E172 : THT 1.00 mm pitch</p> <p>E174 : THT 0.80 mm pitch</p> <p>E119 : SMT 1.27 / 1.50 / 2.00 mm pitch</p> <p>E167 : SMT 1.00 mm pitch</p> <p>E169 : SMT 0.80 mm pitch</p>	<p style="text-align: center;"><b><u>Plating</u></b></p> <p>95: Tin/Gold</p> <p>55: Gold/Gold</p>	<p style="text-align: center;"><b><u>Pitch</u></b></p> <p>12: 1.27 mm</p> <p>10: 1.0 mm (up to 1.26)</p> <p>08: 0.8 mm (up to 0.99)</p>
<p style="text-align: center;"><b><u>Grid code / Config. code</u></b></p> <p style="text-align: center;">Will be given by the factory after receipt of the chip datasheet</p>			



# SMT Solderball MGS adapter series

From 0.8 up to 1.27 mm pitch

The E-tec Interconnect SMT Solderball MGS adapter emulates the package footprint and is easily installed using standard flux and reflow techniques. The solder ball adapters have the same solder ball types as the package's they are emulating. You can combine the SMT foot with any of the E-tec Test socket styles shown in the Test Socket catalogue. The Test Socket is plugged into these adapter, which will be delivered with gold plated through hole pin and alignment plate for easy insertion. We offer any pin-out, configuration and grid size for pitch 0.8mm, 1.00mm and 1.27mm.



Test Socket  
(Plugged into  
adapter)

Solderball SMT  
Adapter

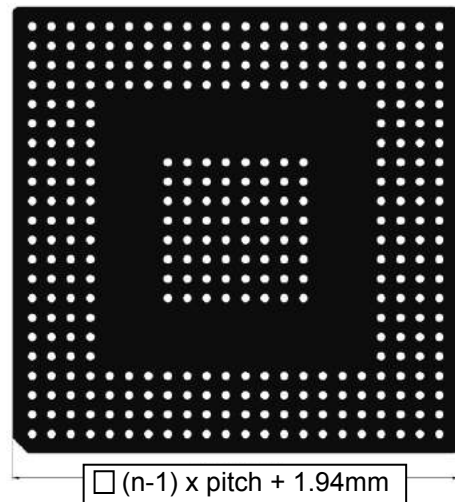
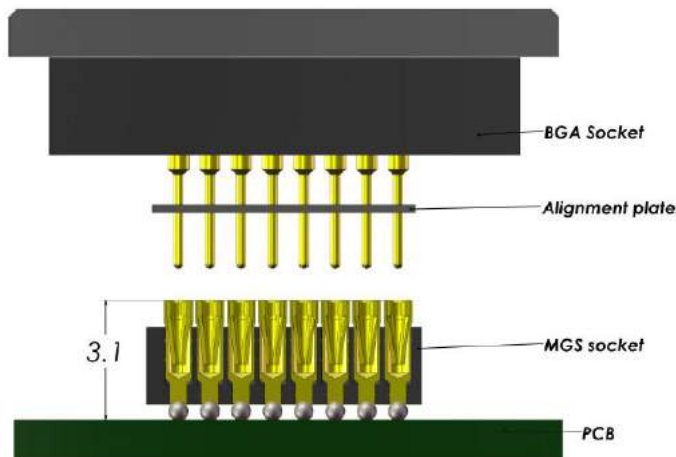

## Specifications

<b>Insulator</b> (Adapter Wafer)	<b>Material:</b> Polyepoxy or equivalent high temp material
<b>Contact</b> (Terminal & Contact Clip)	<b>Material:</b> Terminal CuZn Contact Clip BeCu
<b>Solderball</b>	<b>Material:</b> Sn63Pb 37 (NON RoHS compliant) Sn96.5 Ag 3.0 Cu 0.5
<b>Operating Temperature:</b> -55°C to +125°C <b>Processing Temperature:</b> 260°C for 60 sec. <b>Insertion force:</b> 0.45N/Contact <b>Extraction force:</b> 0.25N/Contact	

## How to order

**MGS #### - SB01 - ### # 5 ##**

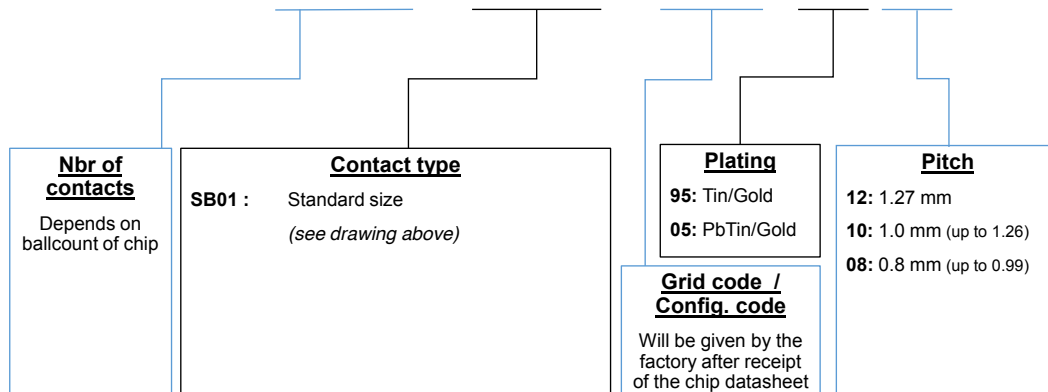



## ZIF Test Socket

For for Flex Cables, Displays and Membrane keyboards  
From 0.40 mm pitch up to 2.54 mm

*E-tec Interconnect AG is the world leading Test socket manufacturer*

The ZIF test Socket are used for functional and reliability high cycle testing for Flex Cables, Displays and Membrane keyboards. Depends on your application, the place on your board and the pitch, you can choose to fix the socket directly on your PCB with our different mounting options or connect your actual PCB with our test adapter with FFC / FPC interface flat cable. In order to provide you with the correct ZIF test socket for your Flex Cables, Displays and Membrane keyboards, we will ask you for device / FFC / FCP drawing, detailed information about the application, cable you are using as well as its dimensions, pitch and performance. We aim to solve your requirements.

## Different sockets series available

### FCT Series

To be fix on your PCB.  
Solderless / SMT / THT  
depend on pitch and application

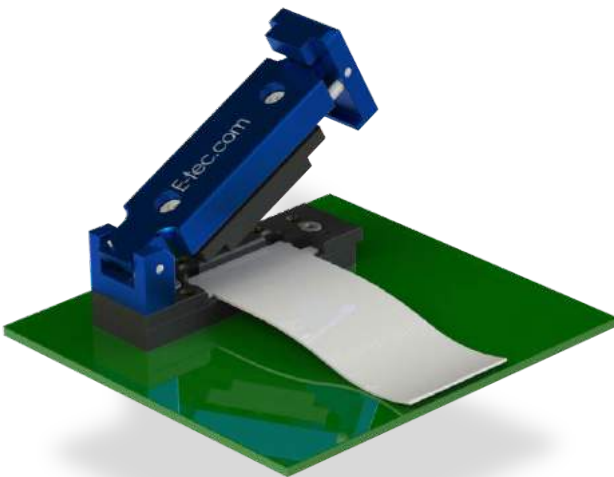

### FCP Series

To be placed outside your PCB.  
Connected with flat cable to your  
actual PCB



### FTU Series

To be placed outside your PCB.  
Connected with flat cable to your actual PCB



More on the next page



# ZIF Test Socket

For for Flex Cables, Displays and Membrane keyboards  
From 0.40 mm pitch up to 2.54 mm

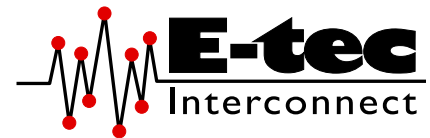

## FCT Series specifications & How to order

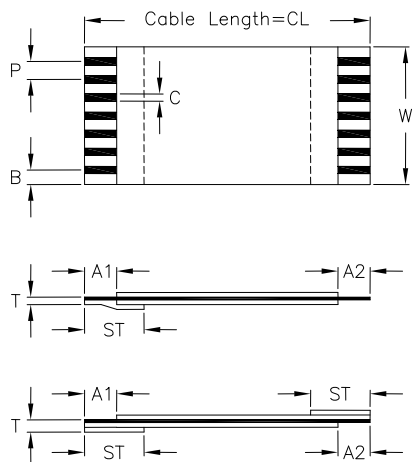
Cable Dimensions	Specifications	
<p>In order to be able to offer the correct socket for your cable, we need to know the type of cable you are using and the corresponding dimensions as shown below.</p> <p><b>Please send the datasheet of your cable together with your socket request.</b></p> 	<p><b>Mechanical data</b> Contact life Retention System life Solderability Individual contact force</p> <p><b>Material</b> Insulator (RoHS compliant) Terminal (RoHS compliant) Spring (RoHS compliant)</p> <p><b>Electrical data</b> Contact resistance Current rating Insulation resistance at 500V DC Breakdown voltage at 60 Hz Capacitance Inductance</p> <p><b>Operating temperature</b></p> <p><b>Processing temperature</b></p>	<p>100K cycles min. 10K cycles min. as per IEC 60068-2-58 40 grams max.</p> <p>High temp plastic or Polyepoxy Brass BeCu</p> <p>&lt; 100 mΩ 1 A – 2 A depend on pitch 100 MΩ if 0.50 to 0.80mm pitch 500 MΩ 1.00mm pitch upwards 500V min. &lt; 1 pF &lt; 2 nH</p> <p>-55°C to +150°C</p> <p>260°C for 60sec.</p>

A detailed socket drawing with the required PCB layout dimensions will be submitted by E-tec for each project.

### How to order

**FCT - x xx- Xxxx - xx**

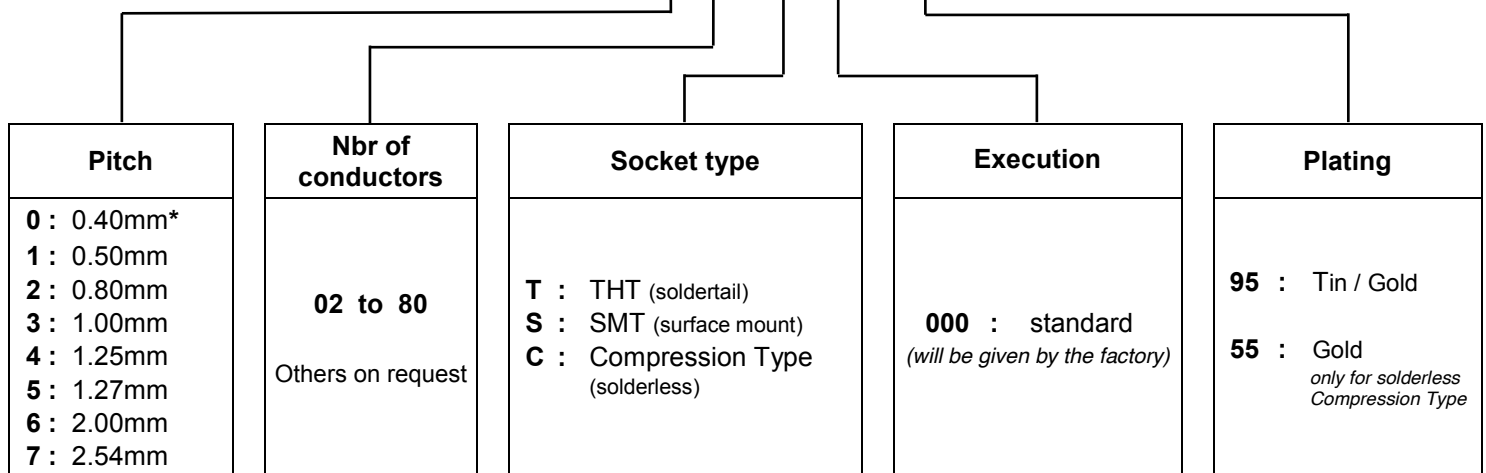

\* Only with Compression socket type

## FCP & FTU Series specifications and How to order

**For more information  
please contact your E-tec Sales office**



### Purpose

This document is meant to serve as a guide for mounting E-tec Interconnect surface mount device (SMD) sockets to the printed circuit board (PCB). The recommendations described here are guidelines only, and modifications may be needed for your particular socket, PCB, and process.

### Application

The sockets this document applies to are as follows: FastLock, ScrewLock, TwistLock, ClamShell, QuickLock and ReverseLock in SMD style. These sockets utilize the E-tec Interconnect patented spring-pin technology. This technology allows the pins to be soldered to the PCB while still providing compliance to the device under test (DUT) via springs located at the other end of the pin. The pins themselves do not have solder pre-forms as a BGA would with its solder balls. However, the sockets are designed to mount to the same PCB footprint and pads as required by the BGA, or any other IC package the socket was designed for (except if locating pegs are used; see 'Locating Pegs' section of this document). When compared to mounting a BGA, an extra volume of solder paste is required to mount the sockets to the PCB. To effect this, a properly dimensioned stencil is required. Once the paste has been applied, a standard reflow process is then used to solder the socket to the PCB. After the socket is verified to have proper electrical connection to the PCB, the system is then ready to be used.

### Locating Pegs

Although designed to mount to the same footprint as the IC, with just a small amount of additional keep-out area, E-tec Interconnect sockets can also be offered with locating pegs. The sockets are typically mounted with two locating pegs, which require two through-holes drilled into the PCB. These pegs help to align the socket on the PCB, and hence align the socket's pins to the PCB's pads, during the soldering process. Furthermore, plating the through-holes allows the locating pegs to be soldered to the PCB for better mechanical stability during everyday use and handling of the socket. If the PCB design permits, E-tec Interconnect recommends the use of these locating pegs. For fine-pitch, low pin-count sockets without locating pegs, the mechanical strength of the solder joints may be insufficient and the same also applies to FastLock, QuickLock, ClamShell & ReverseLock SMT sockets. In these cases, it is recommended to epoxy the socket body to the PCB. 3M Scotch-Weld 2216 B/A is a suitable epoxy. In any case, the proper volume of solder paste is required to ensure mechanical and electrical integrity. Recommended stencil dimensions are given in the next section of this document.

### Mini-grid SMT adapters as an alternative to SMT sockets

Certain customers may find it difficult to solder the E-tec Interconnect SMT sockets (especially high pincount) directly to the PCB, due to the mass of the socket which makes it difficult to properly adjust the soldering process & temperatures. As an alternative, E-tec Interconnect offers mini-grid adapters, i.e. light weight female sockets (mounted with pins or solderballs) for soldering to the PCB (similar to the BGA chip). Thereafter, a through-hole socket can be plugged into this mini-grid adapter, thus doing away with the soldering problems of a rather heavy weight socket.

## Stencil

Table 1 shows the recommended stencil dimensions. A laser-cut, electro-polished and Ni-plated stainless steel stencil is recommended to give the most consistent paste release. The apertures can be made round except for smaller pitches, where square apertures are recommended. Remember to keep the stencil small enough to fit within the keep-out area of the socket, but yet have provisions to remove it from the PCB once the paste has been applied.

Table 1: Recommended stencil dimensions.

Device Pitch (mm)	PCB Pad Diameter (mm / in)	Stencil Thickness (mm/in)	Stencil Aperture (mm/in)
1.2	min. 0.60 / 0.023	0.15 / 0.006	round 0.66 / 0.026
1.0	min. 0.50 / 0.019	0.15 / 0.006	round 0.55 / 0.022
0.8	min. 0.40 / 0.016	0.13 / 0.005	round 0.44 / 0.017
0.7	min. 0.35 / 0.014	0.13 / 0.005	square 0.39 / 0.015
0.6	min. 0.35 / 0.014	0.13 / 0.005	square 0.39 / 0.015
0.5	min. 0.30 / 0.012	0.13 / 0.005	square 0.33 / 0.013

## Solder Paste

E-tec Interconnect recommends using solder paste without ( or <0.5%) silver (Ag) to reduce the solder’s wetting ability and prevent the paste from running up the pins, thus maximizing the volume of solder left on the pads. Brands such as Qualitek ([www.qualitek.com](http://www.qualitek.com)) or Alpha Assembly solutions ([www.alphaassembly.com](http://www.alphaassembly.com)) produce such solder paste on customer request. For Sn/Pb solder paste we recommend Ecorel Easy 802S offered by Avantec ([www.inventec.dehon.com](http://www.inventec.dehon.com)).

## Reflow Profile

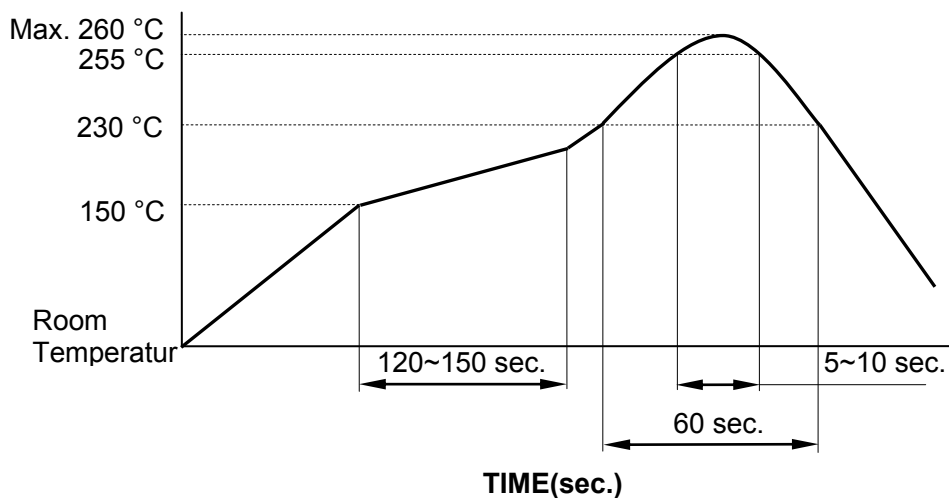

**Notes**

- 1) Temperature indicated refers to the PCB surface temperature at solder tail area.
- 2) Actual reflow profile also depends on equipment, solder paste, PCB thickness, and Other components on the board.  
Please consult your solder paste & reflow equipment manufacturer for their recommendations to adopt a suitable process.

## Classification Reflow Profile as per IPC / JEDEC J-STD-020C

Table 5-2 Classification Reflow Profiles

Profile Feature	Sn-Pb Eutectic Assembly	Pb-Free Assembly
Average Ramp-Up Rate ( $T_{s_{max}}$ to $T_p$ )	3 °C/second max.	3° C/second max.
<b>Preheat</b> – Temperature Min ( $T_{s_{min}}$ ) – Temperature Max ( $T_{s_{max}}$ ) – Time ( $t_{s_{min}}$ to $t_{s_{max}}$ )	100 °C 150 °C 60-120 seconds	150 °C 200 °C 60-180 seconds
Time maintained above: – Temperature ( $T_L$ ) – Time ( $t_L$ )	183 °C 60-150 seconds	217 °C 60-150 seconds
Peak/Classification Temperature ( $T_p$ )	See Table 4.1	See Table 4.2
Time within 5 °C of actual Peak Temperature ( $t_p$ )	10-30 seconds	20-40 seconds
Ramp-Down Rate	6 °C/second max.	6 °C/second max.
Time 25 °C to Peak Temperature	6 minutes max.	8 minutes max.

Note 1: All temperatures refer to topside of the package, measured on the package body surface.

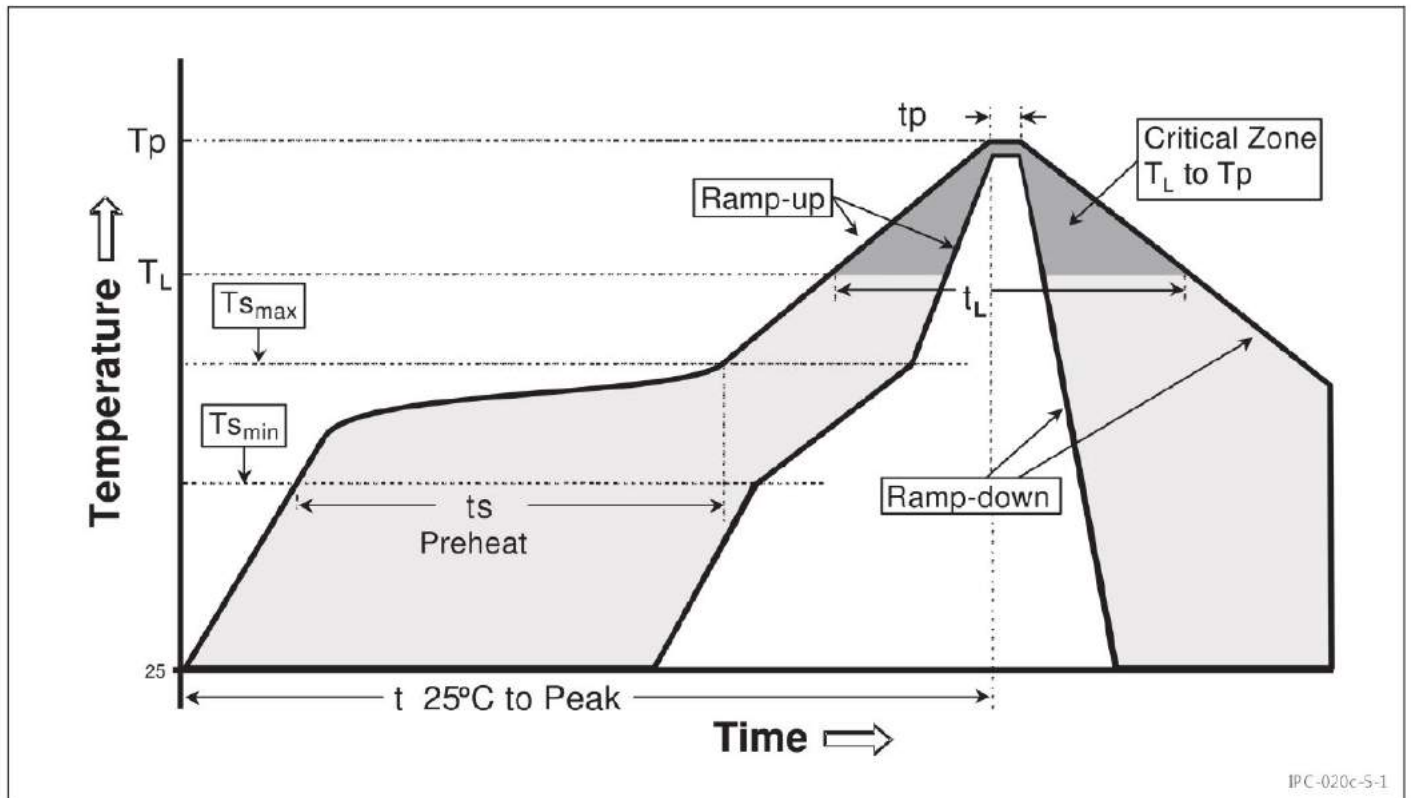

Figure 5-1 Classification Reflow Profile

Table 4-1 SnPb Eutectic Process – Package Peak Reflow Temperatures

Package Thickness	Volume mm <sup>3</sup> <350	Volume mm <sup>3</sup> ≥ 350
<2.5 mm	240 +0/-5 °C	225 +0/-5 °C
≥ 2.5 mm	225 +0/-5 °C	225 +0/-5 °C

Table 4-2 Pb-free Process – Package Classification Reflow Temperatures

Package Thickness	Volume mm <sup>3</sup> <350	Volume mm <sup>3</sup> 350 - 2000	Volume mm <sup>3</sup> >2000
<1.6 mm	260 +0 °C *	260 +0 °C *	260 +0 °C *
1.6 mm - 2.5 mm	260 +0 °C *	250 +0 °C *	245 +0 °C *
≥2.5 mm	250 +0 °C *	245 +0 °C *	245 +0 °C *

\* Tolerance: The device manufacturer/supplier **shall** assure process compatibility up to and including the stated classification temperature (this means Peak reflow temperature +0 °C. For example 260 °C+0°C) at the rated MSL level.

**Note 1:** The profiling tolerance is +0 °C, -X °C (based on machine variation capability) whatever is required to control the profile process but at no time will it exceed -5 °C. The producer assures process compatibility at the peak reflow profile temperatures defined in Table 4.2.

**Note 2:** Package volume excludes external terminals (balls, bumps, lands, leads) and/or nonintegral heat sinks.

**Note 3:** The maximum component temperature reached during reflow depends on package thickness and volume. The use of convection reflow processes reduces the thermal gradients between packages. However, thermal gradients due to differences in thermal mass of SMD packages may still exist.

**Note 4:** Components intended for use in a "lead-free" assembly process **shall** be evaluated using the "lead free" classification temperatures and profiles defined in Tables 4-1, 4.2 and 5-2 whether or not lead free.

## Verifying the Assembly

After the socket has been reflowed to the PCB, open and short testing should be partaken to ensure proper assembly. The assembly house typically performs x-ray inspection to verify non-shortening of pins. However, as this is only a visual inspection, we recommend using a continuity tester or ohmmeter and simply sweeping random rows and columns of pins to ensure no shorting of pins. No damage to the springs will occur if very slight pressure from the meter's tips is applied (just touch the probes to the springs). For fine pitch sockets, a microscope would be helpful in placing the meter's tips appropriately.

After verifying the absence of shorts, open testing should be performed. The most direct, yet tedious, method is to use the continuity tester to directly probe each pin to a breakout or test point on the board. Again no damage will occur if the probes are touched to the springs. If heavy pressure is required to push the socket body towards the PCB to achieve continuity, this means a poor solder joint. If no such test points exist, then the BGA's via field on the backside of the PCB should be kept solder-mask free to allow for such probing. If the via field is kept open, a simpler open testing method can be performed. Simply use a wet sponge (or some other conductive material) and hold it onto the via field. This shorts all the pins together on the PCB. Insert one probe of the continuity tester into the sponge. Now sweep the pins of the socket with the other probe and check for continuity.

If the above procedures show any shorts or opens, then it is advisable to have the assembly house re-evaluate the assembly method used. An incorrect stencil can lead to too much or too little solder paste, easily leading short or open conditions and a solder paste with Ag contents ( $\geq 0.5\%$ ) may also result in solder joint failures. These are the primary reasons for socket mounting failures.



### Important Notes:

#### **a) Screw / TwistLock Socket**

When tightening the lid of a Screw or TwistLock socket, it is imperative to not over-tighten the retention screws, otherwise irreparable damage may occur. Such damage is not covered by warranty and will be solely the end user's responsibility. The maximum allowed torque on these retention screws is 7cN-m (10oz-in) for sockets up to 800 pins and for sockets as of 800 pins the torque value needs to be increased but should not exceed a maximum of 10cN-m (14oz-in). E-tec Interconnect sells the torque screwdriver TOL-7CN-TORQUE which is preset to 7cN-m, but which can be adjusted to higher torque values for the high pin count sockets.

#### **b) FastLock / QuickLock / ClamShell / ReverseLock Socket**

It is recommended to remove the FastLock, QuickLock, ClamShell and ReverseLock retainer from the socket base prior to soldering the sockets to the PCB. This will avoid socket displacement during the soldering process due to the weight of these retainers. User instructions on how to remove and reassemble the retainer from the socket base can be obtained from E-tec Interconnect Interconnect.

#### **c) Pick & Place Pads**

Pick & place pad options can be obtained on request for all SMT sockets. If required, please contact E-tec Interconnect prior to placing a purchase order, since such pick & place pad options may require special fixtures on the socket base which are not included in the standard socket design

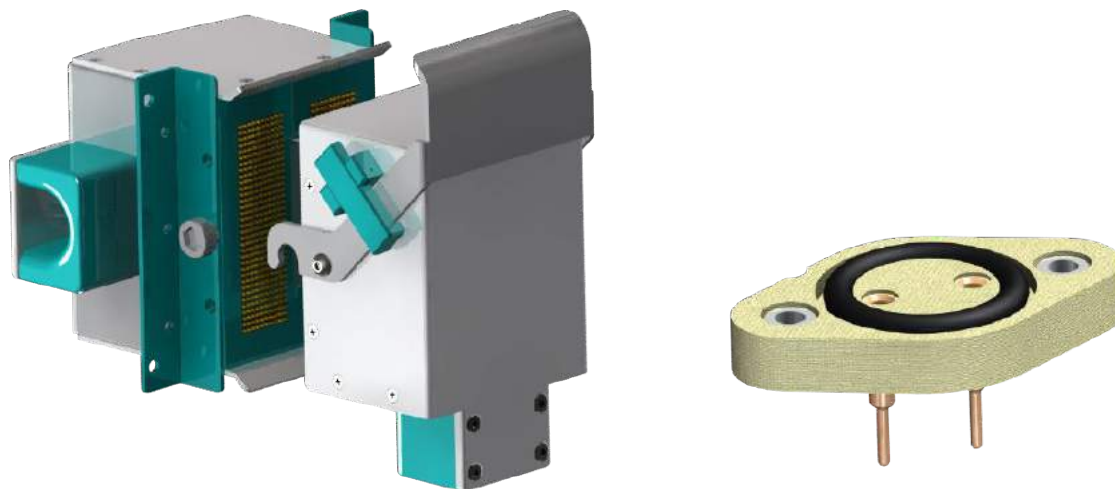

*Customer devices*

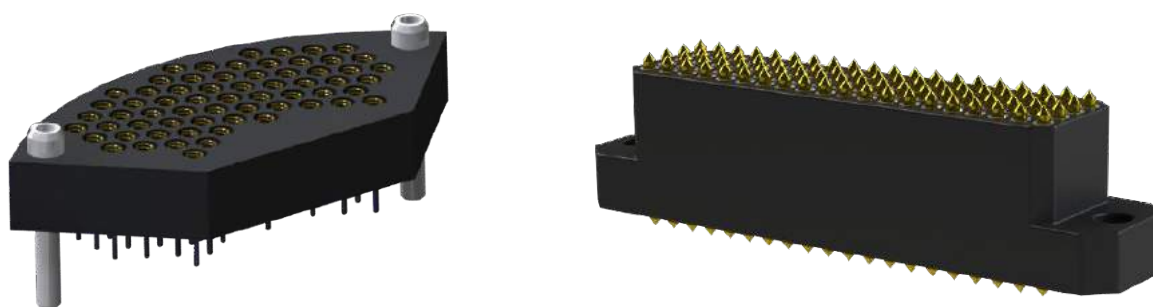

*Embedded Interconnect devices*



*Custom turn pins*

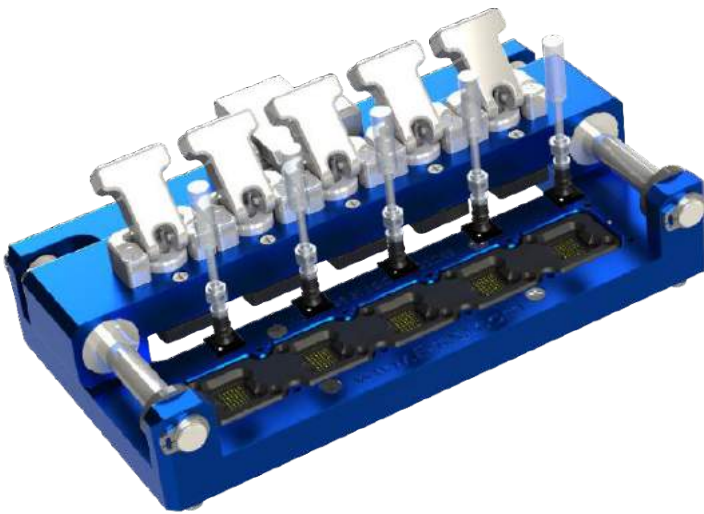

*ATE test socket*

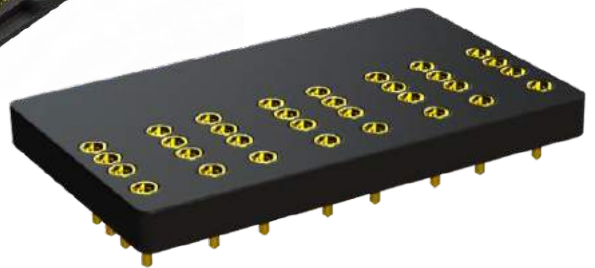
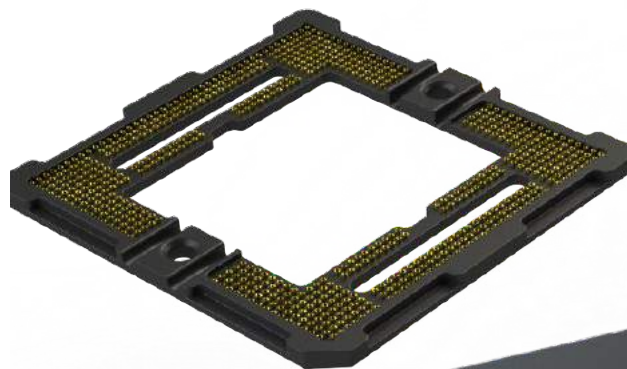

*Onboard socket*

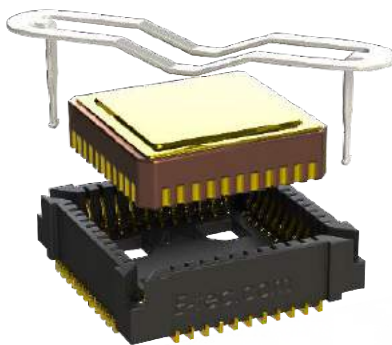

*Embedded onboard sensor sockets*

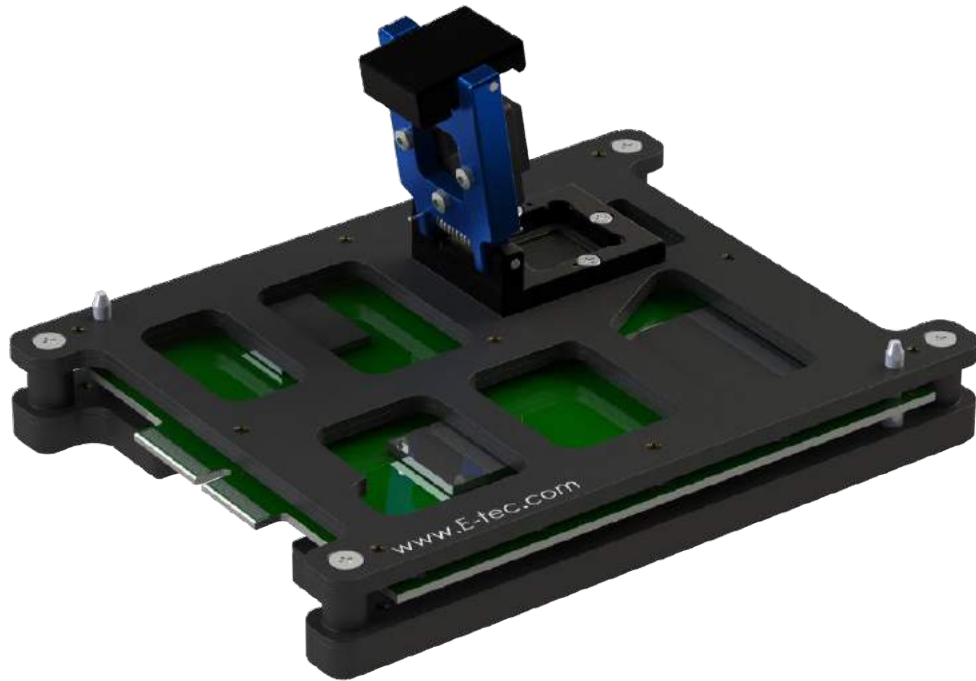

*Bespoke test socket*

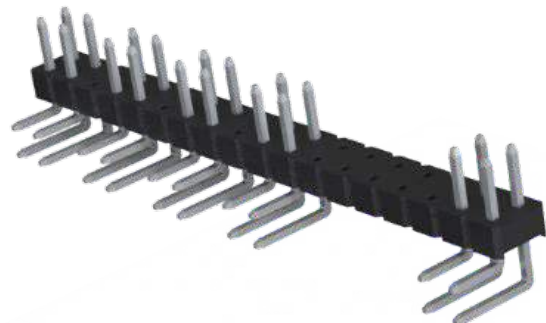
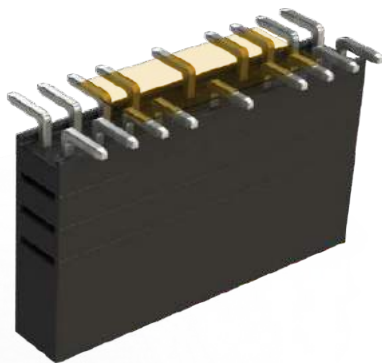
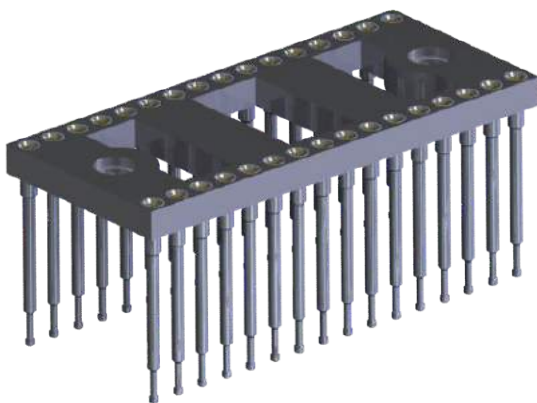
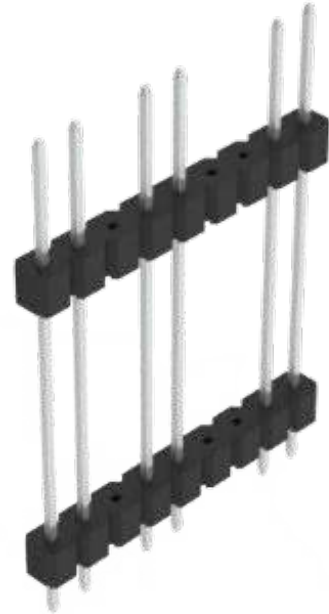
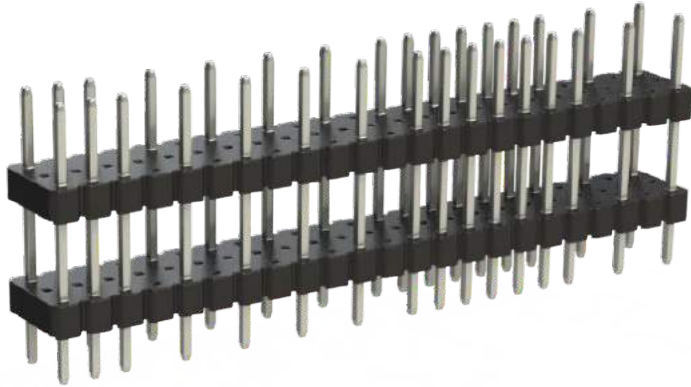

*Industrial connectors*







# The E-tec Group

## International Sales Headquarter and Factory

**Switzerland** **E-tec Interconnect AG**  
Friedhofstrasse 1  
CH-2543 Lengnau b.Biel  
Phone: +41 (0) 32 654 15 50  
Fax: +41 (0) 32 652 26 93  
E-mail: [info@e-tec.com](mailto:info@e-tec.com)  
Web: [www.e-tec.com](http://www.e-tec.com)

## Factory

**Taiwan** **E-tec Interconnect Asia Ltd.**  
7F, No. 69, Sec.2, Guangfu Rd.  
Sancong Dist., New Taipei City  
24158 Taiwan R.O.C.  
Phone: +886 2 2999 2726  
Fax: +886 2 2999 5255  
E-mail: [info@e-tec.asia](mailto:info@e-tec.asia)  
Web: [www.e-tec-asia.com.tw](http://www.e-tec-asia.com.tw)

## Related Sales Headquarters

**Germany** **EMC**  
**Electro mechanical components GmbH**  
Deningerstrasse 4a  
D-65510 Idstein  
Phone: +49 (0) 6126 93 95-0  
Fax: +49 (0) 6126 93 95-72  
E-mail: [info@emc.de](mailto:info@emc.de)  
Web: [www.emc.de](http://www.emc.de)

**England** **E-tec Interconnect (UK) Ltd**  
Units A5 & A6 Decimus Park  
Kingstanding Way  
Tunbridge Wells  
Kent TN2 3GP  
Phone: +44 (0) 18 92 53 02 60  
Fax: +44 (0) 18 92 51 55 60  
E-mail: [info@e-tec.co.uk](mailto:info@e-tec.co.uk)  
Web: [www.e-tec.co.uk](http://www.e-tec.co.uk)

**France** **Steliau Technology**  
41-43, rue Périer  
92120 Montrouge  
Phone: +33 (0) 1 55 58 04 04  
Fax: +33 (0) 1 55 58 04 00  
e-mail: [contact@steliau-technology.com](mailto:contact@steliau-technology.com)  
Web: [www.steliau-technology.com](http://www.steliau-technology.com)

**USA / Canada** **E-tec Interconnect USA**  
18615 Arguello Ave  
Morgan Hill, CA 95037  
Phone: +1 408 778 2800  
Fax: +1 408 823 7724  
E-mail: [info-us@e-tec.com](mailto:info-us@e-tec.com)  
Web: [www.e-tec.us.com](http://www.e-tec.us.com)

## TopLine Corporation

95 Highway 22 W.  
Milledgeville, GA 31061  
Phone: +1 478 451 5000  
Fax: +1 478 451 3000  
E-mail: [sales@TopLine.tv](mailto:sales@TopLine.tv)  
Web: [www.TopLine.tv](http://www.TopLine.tv)

**India** **E-tec Interconnect AG India**  
#1/1, Sai Towers, RV Road,  
Diagonally OPP to Kamath Hotel  
Basvanagudi, BANGALORE - 560004  
Phone: +91 (0) 9663112596  
E-mail: [info.india@e-tec.com](mailto:info.india@e-tec.com)  
Web: [www.e-tec.com](http://www.e-tec.com)

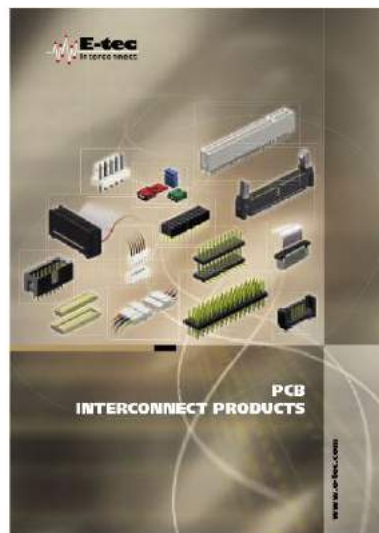
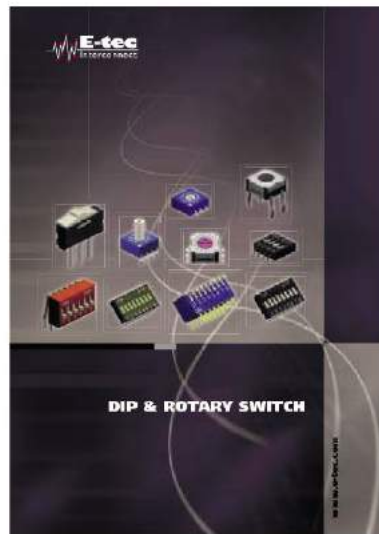

Your authorised distributor: